



**Modern Journal of Language Teaching Methods**

**ISSN: 2251-6204**

# **Modern Journal of Language Teaching Methods**

---

**ISSN: 2251-6204**

# Modern Journal of Language Teaching Methods (MJLTM)

ISSN: 2251 - 6204

[www.mjltm.com](http://www.mjltm.com)

[info@mjltm.org](mailto:info@mjltm.org)

## *Editorial Board:*

1. Hamed Ghaemi, Assistant Professor in TEFL, Islamic Azad University (IAU), Iran
2. Domingo Docampo Amoedo, Full Professor, Department: Signal Theory and Communications, Vigo University, Spain
3. Barbara Sicherl Kafol, Full Professor of Music Education University of Ljubljana, Slovenia
4. Agüero-Calvo Evelyn, Professor of Mathematics, Technological Institute of Costa Rica
5. Tito Anamuro John Albert, Assistant professor Universidad del Norte, Colombia
6. Dlayedwa Ntombizodwa, Lecturer, University of the Western Cape, South Africa
7. Doro Katalin, PhD in Applied Linguistics, Department of English Language Teacher Education and Applied Linguistics, University of Szeged, Hungary
8. Dutta Hemanga, Assistant Professor of Linguistics, The English and Foreign Languages University (EFLU), India
9. Fernández Miguel, PhD, Chicago State University, USA
10. Grim Frédérique M. A., Associate Professor of French, Colorado State University, USA
11. Izadi Dariush, PhD in Applied Linguistics, Macquarie University, Sydney, Australia
12. Kaviani Amir, Assistant Professor at Zayed University, UAE

13. Kirkpatrick Robert, Assistant Professor of Applied Linguistics, Shinawatra International University, Thailand
14. Mouton Nelda, PhD in Education Management, North-West University (NWU), South Africa
15. Naicker Suren, Department of Linguistics and Translation, University of South Africa
16. Ndhlovu Finex, PhD, Linguistics Programme, University of New England, Australia
17. Raddaoui Ali Hechemi, PhD, Associate Professor of Applied Linguistics, University of Wyoming in Laramie, USA
18. Rolstad Kellie, PhD, Associate Professor of Education, University of Maryland, USA
19. Shahbazirad Mohammad, PhD candidate in English language and Literature, Yerevan State University, Armenia
20. Stobart Simon, PhD, Dean of Computing, Teesside University, UK
21. Suszczyńska Malgorzata, Senior Assistant Professor, University of Szeged, Hungary
22. Weir George R. S., PhD in Philosophy of Psychology, University of Strathclyde, Glasgow, UK
23. Zegarac Vladimir, PhD, University of Bedfordshire, UK

## Abstracting/Indexing



THOMSON REUTERS



CiteFactor  
Academic Scientific Journals

*Index Copernicus 2011*



*Linguistics Abstract*

# Linguistics Abstracts Online

*EBSCO Publication*



*Lulu Publication*



*Directory of Open Access Journals*



*ProQuest*



*Modern Language Association*



*Cabell's Directories*



*COPE*



*Directory of Research Journal Indexing (DRJI)*



*Indian Citation Index*



*International Society of Universal Research in Sciences*



**International  
Society of Universal  
Research in Sciences**

Ulrich's



**ULRICH'S**WEB™  
GLOBAL SERIALS DIRECTORY



## Table of Contents

### **Vocal Hygiene as a Treatment for Teachers: A Review**

Atoosa Mozafar Zangeneh<sup>1</sup>, Farzad Izadi<sup>2</sup>, Leila Ghelichi<sup>3</sup>

### **An Analysis of Translation Strategies in the Persian Translation of Woody Allen and Fernando Sorrentina's Comic Stories Adopted by Hossein Yaghoobi**

Mehri Farzaneh<sup>a</sup>, Mostafa Movahed, Zahra Yazdani Zadeh

### **The Effect of Age at Implant on the Vowel Space of Cochlear Implanted Children**

Seyedeh Zahra Asghari<sup>a</sup>, Fatemeh Nemati<sup>b</sup>, Rezvan Akbari Manie<sup>c</sup>, Farzaneh Esna-Ashari<sup>d</sup>, Farhad Farahani<sup>e</sup>

### **Valence effects on phonological processing in normal Persian speaking children: A study by ERP**

Sousan Salehi<sup>1</sup>, Ahmad Reza Khatoonabadi<sup>1\*</sup>, Mahmoud Reza Ashrafi<sup>2</sup>, Ghasem Mohammadkhani<sup>3</sup>, Saman Maroufizadeh<sup>4</sup>

### **The Rhetorical Preference of Quran's Different Chapters**

Mehrnoosh Eslami<sup>1</sup>, Seyyed Fazel Fazeli<sup>2</sup>, Naser Rashidi

### **A Cross-Cultural Move Analysis of Master and Doctoral Theses/Dissertations Acknowledgment across Gender: the Case of Applied Linguistics Discipline**

Ali M. Fazilatfar, Hossein Kargar Behbahani, Mina Hosseini

### **The Motivational Outcomes Of Connectivism Theory In EFL**

Mohammad Borna (corresponding author)<sup>1</sup>, Mahboobeh Fouladchang<sup>2</sup>

### **An overlook on musical and semantic repetition in Persian poem**

Dr. Asadollah Jafari, Seyyed Hosein Mostafavi

### **A Look at the Function of Father and Son in the Epic Literature of Iran and the World**

Asadollah Jafari<sup>1</sup>, Elham Choobineh<sup>2</sup>

### **Bashkir Epic "Ural-Batyr": Traditions of Its Modern Recitation and New Projections of Its Archaic Character**

Rosalia A. Sultangareeva

### **Teaching Foreign Language: Teaching... Or Fraud?**

Sergey Anatoljevich Filatov

### **A Model for Interpreting Author's Intent in the Text of a German Short Story**

Tatiana N. Lapchinskaya

### **Language And Social Structure**

Olga B. Istomina

### **Modern Language Policy: Specifics Of Formation And Development Of The French Vertical**

Dmitry Yu. Gulinov<sup>1</sup>, Marina R. Zheltukhina, Larisa A. Shestak, Gennady G. Slyshkin, Veronica V. Katermina and Ludmila D. Chervyakova

**Linguacultural Specificity Of Transferring The Category Of Comic By The Language Means**

Aida G. Sadykova<sup>1</sup>, Diana F. Kajumova<sup>2</sup>, Diana N. Davletbaeva<sup>3</sup>, Gulnara H. Aleeva<sup>4</sup>, Elena L. Iakovleva<sup>5</sup>, Marina A. Zaichenko<sup>6</sup>, Galina V. Matveeva<sup>7</sup>

**The Adequacy Of The Reflection Of The Comic By Means Of Another Language: Translation Equivalence And Adequacy.**

Diana F. Kajumova<sup>1</sup>, Aida G. Sadykova<sup>2</sup>, Gulnara H. Aleeva<sup>3</sup>, Luiza R. Zakirova<sup>4</sup>, Galina V. Kolpakova<sup>5</sup>, Liliya I. Galeeva<sup>6</sup>, Gulnara A. Arslanova<sup>7</sup>

**Public Trust Of The Population In Economic Reforms: A Theoretical And Practical Aspect**

Elena V. Kamneva<sup>1</sup>, Marina V. Polevaya<sup>2</sup>, Sergey A. Polevoy<sup>3</sup>, Nikolay S. Prjazhnikov<sup>4</sup>, Tatiana V. Folomeeva<sup>5</sup> & <sup>6</sup> Eleonora V. Egorova

**Psychological And Pedagogical Support Of Parents In Developing Social Adaptation Resources In Inclusive Education Participant**

Svetlana V. Gridneva<sup>1</sup>, Yuri A. Bubnov<sup>2</sup>, Tatiana A. Dronova<sup>3</sup>, Oksana V. Shabanova<sup>4</sup>, Svetlana N. Kazakova<sup>5</sup> & Ludmila N. Gridyaeva<sup>6</sup>

**Social Exclusion As Theoretical Construct: Conceptualization Problems**

Tatiana I. Barsukova<sup>1</sup>, Lyudmila A. Shvachkina<sup>2</sup>, Valentina I. Rodionova<sup>3</sup>, Lyudmila A. Saenko<sup>4</sup>, Stanislav T. Baranov<sup>5</sup>

**Family Psychological Violence Influence On Adolescent Aggressive Behavior Formation**

Valentina I. Rodionova<sup>1\*</sup>, Lyudmila A. Shvachkina<sup>2</sup>, Leila E. Kuznetsova<sup>3</sup>

## Vocal Hygiene as a Treatment for Teachers: A Review

Atoosa Mozafar Zangeneh<sup>1</sup>, Farzad Izadi<sup>2</sup>, Leila Ghelichi<sup>1</sup>

PhD candidate of speech & language pathology, Department of speech & language pathology, School of Rehabilitation Sciences, Iran University of Medical Science, Tehran, Iran.

MD, Associate Professor of Otorhinolaryngology, Fellowship of laryngology, Department of Otolaryngology Head & Neck Surgery, Rasoul Akram Hospital, Iran University of Medical Science, Tehran, Iran.

PhD, Assistant Professor of speech & language pathology, Department of speech & language pathology, School of Rehabilitation Sciences, Iran University of Medical Science, Tehran, Iran.

### Abstract

**Introduction:** Prevention of voice problems of teachers is very important because of its negative effects on teacher's quality of life and work. Therefore, prevention of voice disorders of teachers has been a main subject in many studies related to educational and direct voice intervention programs. Vocal hygiene is one of the main components in the treatment of teachers' voice complaints.

**Objective:** Vocal hygiene methods divided to two parts for reviewing the studies related to preventive vocal treatment methods of teachers: First, vocal hygiene program which includes techniques that educate patients about normal and abusive voice production (preventive or indirect method); The other procedure is vocal educational programs which have two parts (preventive and direct method).

**Materials and Methods.** A survey over the vocal hygiene literature was conducted using the following electronic databases to provide this narrative review: Cochrane Library, OvidSP, Science Direct, Springer, Scopus, Google Scholar and PubMeb. These searches were done using the following key words: voice hygiene, voice educational program, voice training program and teacher. Selected essays were published or accepted from 2000 till 2015. totally, 14 articles that investigated the impact of voice hygiene or voice education program or both on the vocal quality of teachers were selected for this review.

**Keywords:** Voice disorders; Teacher; Dysphonia; Professional voice; Treatment; Vocal hygiene

### Introduction

Voice is one of the most important ways of communicating of each person. So any injury or disorder can cause social or occupational difficulties.

Professional voice user is a person whose professional role and employment is depended on the usage of a "good" voice (e.g. A singer, actor, teacher, lawyer, minister or public speaker) [1, 2]. Several studies have shown a high incidence (about 14.6%) of voice disorders in teachers, along with the personal, professional and economical consequences of the disorder. (3) It is also explained that teachers are at the highest risk for developing signs and symptoms of vocal problems. Voice problems are result of hyper functional vocal behavior and the main complaints are temporary voice loss hoarseness, tiredness and fatigue [1, 4-7]. This kind of voice disorders may have negative effect on teacher's quality of life and work [1, 2, 4].

Prevention of voice problems in teachers has been a main subject in many studies related to educational and direct voice intervention programs. In these studies, a comparison made between voice educational programs and voice training exercises. Several authors believed that vocal educational programs or indirect interventions for teachers can prevent from occupational dysphonia and inform teachers about the signs of voice disorder onset [3, 4, 8-12]. Educational or indirect programs are consisting of vocal hygiene habits. They help professional voice user to understand vocal anatomy and voice use, the effect

<sup>1</sup> Corresponding Author: Leila Ghelichi, PhD, Assistant Professor of speech & language pathology, Department of speech & language pathology, School of Rehabilitation Sciences, Iran University of Medical Science, Tehran, Iran.

of environmental factors on voice efficacy, healthiest possible behaviors and conditions that promote laryngeal and vocal health and eliminate vocal disorders [2, 4, 9, 13-16]. On the other hand, vocal hygiene programs are time and cost effective for both patient and therapist.

As mentioned above, suitable voice is very important for different aspects of teacher's live, so the aim of this review is to investigate the effectiveness of the vocal hygiene programs as an indirect therapy for voice disorders in teachers' guild. We don't want to compare the direct and indirect protocols but instead our aim is to study the vocal hygiene programs advantages in comparison with voice educational programs advantages for teachers as a main group of occupational voice disorders patients.

### Vocal Hygiene Treatment Methods

Vocal hygiene is considered as a patient oriented behavioral treatment that employed as both a preventive and therapeutical (or direct and indirect) strategy [10, 17-19].

So treatment methods that contain vocal hygiene strategies can be classified into two separate groups: 1) Vocal hygiene program which includes techniques that educate patients about normal and abusive voice production and effects of environmental factors and individual habits on voice to prevent or reduce voice disorders (preventive or indirect method) [5, 10, 11, 20-26]. 2) Vocal educational programs which have two phases; in one section they have traditional (preventive) vocal hygiene program and in another section they introduce some kind of voice training methods to shape or reform voice producing approach [3, 4, 8, 27-30]. This approach addresses both speech and non-speech factors which control voice production with cognitive-behavioral techniques [10].

In this section we only mention the studies that used vocal hygiene program as their main treatment strategy for teachers and did not use the voice shaping programs (group or individual therapy).

Pizolato et al. [27] investigated two groups of teachers. The 40 teacher in the first group participated in 2 lectures that gave them guidance on vocal hygiene habits. In another group beside lectures they had training exercises. In the lecture, the teachers were informed about how the voice is produced, and which the pathologies that may cause voice disorders are. The participants also instructed to practice healthy voice habits. Vocal hygiene program was focused on the importance of intake water, the effect of eating on the vocal tract, management of the vocal tract mucosa, and vocal rest as after work. The subjects were instructed to avoid vocal habits that are dreadful to the voice, such as: speaking loudly, shouting, throats clearing, speaking over background noise, overall speaking in uncomfortable positions, the use of sprays, constant intake of cold drinks, sudden changes in body temperature without suitable clothing for the situation, practicing physical activities and poor sleep quality. In both groups teachers showed higher overall V-RQOL scores after therapy. But, there were no statistical difference in scores between the groups.

In another study Roy et al. [8] divided participants in to 3 groups. In one of the groups 15 teachers participated in the voice hygiene sessions. The teachers underwent treatment over a 6-week period which was 4 sessions. Clinicians provided a VH program, and delivered written instructions that teachers must followed them. The VH program was gathered from a Morrison et al. template and with some suggestions from other sources. The Morrison et al. hygiene program included components which are presented in most traditional VH treatment programs. Ambiguous details of the vocal hygiene program were reviewed with the clinicians. All clinicians have had such VH programs before. In the VH group, subjects followed each week, for tracking all of vocal hygiene suggestions/ behaviors. Based on pre- and post-treatment comparisons, they observed desire improvements but there were no significant changes on mean VHI scores, voice severity self-ratings, and the acoustic measures of percent jitter and shimmer. In comparison with control group both treatment groups experienced more improvement but there were no significant differences between treatment groups.

Pasa et al. [9] have investigated the effects of vocal hygiene program and vocal functional exercises on teacher's voice. In VH group 13 teachers had four sessions in ten weeks. The purpose of this training was

to learn correct vocal behaviors especially in the school environment. The topics of the VH session were the prevalence and effect of voice disorders in teachers, anatomy and physiology of voice, symptoms and etiology of voice disorders, methods to eliminate abusive vocal behaviors, management of health factors that cause or establish voice problems, and optimizes the speaking environment that maximize vocal efficiency and eliminate vocal injuries. The results revealed that VH appeared to be more effective in increasing knowledge of voice and decreasing vocal misuse behaviors. In addition, VH was shown to be more useful than VFE by subjects in the study.

Nanjundeswaran et al. [31] in their study, examine two types of treatment. They had individually tailored VH program and the VH program plus resonant VT (VH + VT). Study conducted both in Pittsburgh and Hong Kong and subjects were student teachers. Interventions in Pittsburgh and Hong Kong had same format, except for language of delivery (English in Pittsburgh and Cantonese in Hong Kong). At first, 7 teachers participated in 2-hour educational lectures on VH. After a short 10 to 15 minutes conversation, clinician adopted VH program for each participant with main focus on hydration, control external inflammation factors, and prohibit yelling and screaming. Results suggest that a minimalist, individually tailored VH program may be adequate to prevent voice disorders in healthy student teachers except subjects had more serious problems.

Bovo et al. [32] in another study investigate teacher's voice in two groups; one of them only delivered two theoretical lectures, each 60 min long and in another group they had two lecture and three-month use of a portable vocal amplifier. In first group 20 participants did not receive any direct treatment; but, they inform about vocal hygiene norms. Data suggested that in course only group outcome measures changed but the results were not statistically significant.

In another study of Roy and his colleagues [33] they divided teachers in three groups: vocal hygiene, vocal function exercises, and a non-treatment control group. As their former study they use the VH program that adapted from a Morrison et al. template and the treatment plan was exactly the same too [8]. In three group comparison, data revealed that VFE group had better treatment result and subjects were more satisfied with it. VH group was better than controls but had lower scores in outcome measurements.

In this part we mention the studies that use vocal hygiene as one of their treatment methods and compares it with one of the voice therapy techniques or control group. The results are controversial; half of the researches show that vocal hygiene has better or the same effect of voice therapy techniques [8, 9, 27] and others showed reverse results [3, 31, 33]. But in all of studies vocal hygiene groups have better outcome than control groups [3, 8, 9, 31-33].

Authors	Participants	Type of treatments	Outcome measure	Results
Pizolato et al. 2013(27)	70 teachers from public schools	vocal hygiene and voice training exercise	Voice-Related Quality of Life instrument  V-RQOL	(i) Improvement in voice quality was observed in the group with vocal hygiene guidance.  (ii) There was no significant difference between groups.

ACCEPTED

Roy et al. 2002 (8)	50 full-time elementary and secondary school teachers with a history of voice problems	voice amplification using the ChatterVox portable amplifier (VA), vocal hygiene (VH), and a non treatment control group	Voice Handicap Index (VHI), a voice severity self-rating scale and acoustic analysis	(i) Compared to the control group, both treatment groups experienced more improvement on specific outcomes measures. (ii) There were no significant differences between the VA and VH groups.
Pasa et al. 2007 (9)	37 primary school teachers	vocal hygiene training (VH), vocal function exercises (VFE) and control group	voice knowledge and self-report questionnaire and acoustic analysis	(i) VH and VFE subjects reported improved vocal characteristics and voice knowledge after training while the control group showed deterioration on most variables. (ii) VH participants showed greater improvements than the VFE participants.
Nanjundeswaran et al. 2012 (31)	31 female and male student teachers in Pittsburgh and Hong Kong (29 female and 2 male)	Individually tailored VH program, the VH program plus resonant VT (VH + VT) and a control group	Voice Handicap Index (VHI)	(i) Minimalist, individually tailored VH program may be sufficient to prevent voice problems. (ii) For participants with existing voice problems, VT may be required to maximize results of intervention.
Bovo et al.(32)	40 female primary school teachers	Course(VH lecture) plus vocal amplifier group and course only group	Voice Handicap Index (VHI) and perceptual grade of dysphonia	(i)After 3 months, results in "course + amplifier" group demonstrated a significant amelioration. (ii) The same measures also changed in the "course only" group, but the results were not statistically significant.
Roy et al. 2001 (33)	Sixty full-time elementary and secondary school teachers with a history of voice problems	vocal hygiene (VH), vocal function exercises (VFE), and non treatment control group	Voice Handicap Index (VHI) and teacher's questionnaire	VFE group showed higher scores both in VHI and questionnaire than VH group

TABLE1. Summaries of studies using Vocal hygiene program

### Vocal educational programs

In this part we only point out the studies that used vocal education program as one of their main treatment strategies for teachers (group or individual therapy). This program contains both vocal and environmental elements of voice production.

In the Bovo et al. [3] study 64 women teachers divided in two groups. 23 teachers in first group received professional voice user course (4 sessions) and an instructional pamphlet and during next 3 months they focused on the vocal ergonomics norms and fill out daily reports and do their exercises and report the outcome. Another group is control group. Twelve months later teachers in two groups compared and results revealed that acoustic and VHI parameters is better in treatment group but there was no significant difference in stroboscopic results in two group.

Pizolato et al. [4] examined two groups of teachers. In the first group teachers participated in 2 vocal hygiene habits lectures. In the experimental group there were 36 teachers who received lecture and four voice training exercise sessions. The sessions include four main topics: 1) posture and cervical relaxation; 2) respiration; 3) phonation, frequency, and intensity; and 4) resonance and articulation. Voice training exercises showed a positive and immediate effect on quality of voice, but it was not continued longitudinally.

Gillivan-Murphy et al. [34] assigned 20 teachers in two treatment and control group. In treatment group participants received direct treatment for 5 to 6 sessions in 8 weeks. The treatment procedure was same as VFE techniques used by Roy et al. [33] that described in the previous section. The indirect phase of treatment (VH) contain written information on the different parts (medical, vocal abuse and misuse, health, emotion and environmental). The main source for VH information was Morrison and Rammage model. Control group received no treatment. Treatment group showed enhanced voice symptoms and voice care information in all of self-reported masseurs except VQRL than control group.

In their study, Faham et al. [35] recruited 61 teachers to treatment group and 66 teachers to control group. Treatment group received voice education program in 4 weeks and continued to use it for another 4 weeks. Participants in treatment group learned some vocal hygiene issues (voice production, voice and larynx protection, vocal abusive behaviors detection, prevention and substitution), correct breathing patterns and effect of them on voice production and laryngeal muscle tension and reduction of it. Control group received no treatment. Teachers in the experimental group improved notably in VHI score, whereas teachers in the control group showed deterioration.

Duffy and Hazlett [36] in their study examined 55 teachers and divided them in three groups. 23 teachers were in the control group, 20 in the indirect treatment group, and 12 in the direct treatment group. In the indirect group information presented about vocal hygiene tips in daily life. In direct group despite this information, they also provided trainings about posture, respiration, release of tension in the vocal tract, resonance, and voice projection. Acoustic and self-perceptual assessments showed deterioration for the control group, progression for the direct group, and no change for the indirect group.

Richter et al. [37] investigated 204 student teachers in two groups: training group consisted of 123 participants and control group consisted of 81 participants. In the training group participants received training in 1.5 year; 8 sessions in first half that included voice hygiene, postural alignment, breathing control, optimal pitch, vocal intensity, vocal resonance, articulation and prosodic information. Two review sessions in second half and a voice teacher that screened vocal parameters in last half. The training group demonstrated improved voice quality compared with control group, whose voice qualities worsen. But both groups reported increase in self-reported vocal strain.

65 future teachers enrolled in Timmermans et al. [38] research. Students divided in two groups (32-person training group and 30-person control group). The voice training group received 3 hours of indirect and 3 hours of direct training. The indirect treatment focused on reducing the factors that cause a voice problem. On the other hand, direct treatment concentrated on the voice production, such as an



appropriate posture, breathing techniques and good breath support; find optimal pitch, the control of pitch, voice projection, resonance and articulation. After 4 months subjective measurements (voice loading test and dysphonia severity index (DSI)) revealed no differences between groups. In contrast, objective measurements (GRBAS) showed several significant differences between two groups.

In their later study Timmermans et al. [39] investigated 81 students (27 males and 54 females). The trained group (n = 51) received the same treatment protocol as their earlier research [38], plus 30 minutes individual training for each person. The control group (n = 30) received no treatment. Again after 4 months subjective measurements demonstrated no major change except in strain parameter; and objective measurements also showed improvements in many parameters between two groups.

In this part we pointed out the researches that used vocal educational program as one of their treatment protocols; and mainly compare it with no treatment group. It is obvious that different vocal educational programs with different durations all have positive effect on voice qualities in different studies.

**TABLE 2. Summaries of studies using Vocal education program**

Authors	Participants	Type of treatments	Outcome measure	Results
Bovo et al.(3)	64 women teach in elementary and kindergarten school	professional voice users course (4 session)	stroboscopy, perceptual and electro-acoustical voice analysis, Voice Handicap Index, and a course benefit questionnaire	<b>A year after the course, the positive effects kept on, but they were a little reduced</b>
Pizolato et al. 2013(4)	81 women and 21 men teaching in public schools	Experimental group: vocal hygiene and voice training exercise Control group	Acoustic analysis of the vowel [i]	<b>(i) Improvement in voice quality was observed in the experimental group with voice training exercise. (ii) Voice training exercises showed a positive and immediate effect on quality of voice, but it was not continued longitudinally.</b>
Gillivan-Murphy et al.(34)	20 school teachers	Treatment group: vocal function exercises (VFEs) and vocal hygiene (VH) education Control group	Self-report questionnaire: Voice-Related Quality of Life (VRQOL), the Voice Symptom Severity Scale (VoiSS) and Voice Care Knowledge Visual Analogue Scale (VAS)	<b>Direct treatment that contains VFEs and VH education enhanced self reported questionnaire and voice care information.</b>
Faham et al.(35)	61 teachers in the treatment group and 66 teachers in the control group	I Treatment group: some vocal hygiene issues, correct breathing patterns and effect of them on voice production and laryngeal muscle tension and reduction of it Control group	Voice Handicap Index (VHI)	<b>Teachers in the experimental group improved notably in VHI score, whereas teachers in the control group showed deterioration</b>
Duffy and Hazlett (36)	55 teachers divided in three groups: 23 were in the control group, 20 in the indirect treatment group, and 12 in the direct treatment group	Indirect group: vocal hygiene (VH), direct group : vocal hygiene (VH) + information about posture, respiration, release of tension in the vocal tract, resonance, and voice projection Control group	Acoustic measurements: highest frequency, lowest intensity, maximum phonation time (MPT), and jitter. self-perceptual measurements: Vocology Screening Profile (VSP) and Voice Handicap Index (VHI)	<b>Acoustic and self-perceptual assessments showed deterioration for the control group, progression for the direct group, and no change for the indirect group.</b>
Richter et al. (37)	204 student teachers in two groups: training group consisted of 123 participant and control group consisted of 81 participants	voice hygiene and voice education program and control group with no treatment	videostroboscopy, VHI, the highest fundamental, the lowest intensity, the jitter, MPT and a vocal loading test	<b>(i)The training group demonstrated improved voice quality compared with control group, whose voice qualities worsen. (ii) Both groups reported increase in self reported vocal strain.</b>

(VLT)				
Timmermans et al. (38)	65 future teacher in two groups:  32 student in training group and 30 student in control group	3 hours indirect treatment: reducing the factors that cause a voice problem. 3 hours direct treatment: posture, breathing, pitch, voice projection, resonance and articulation  control group	subjective measurements: voice loading test and dysphonia severity index (DSI)  objective measurements: GRBAS	(i) <b>Subjective measurements revealed no differences between groups.</b>  (ii) <b>Objective measurements showed several significant differences between two groups.</b>
Timmermans et al. (39)	81 students (27 males and 54 females) in two groups:  51 student in training group and 30 student in control group	3 hours indirect treatment: reducing the factors that cause a voice problem. 3 hours direct treatment: posture, breathing, pitch, voice projection, resonance and articulation plus 30 minutes individual training  control group	subjective measurements: voice loading test and dysphonia severity index (DSI)  objective measurements : GRBAS	(i) <b>Subjective measurements revealed no differences except in strain parameter between groups.</b>  (ii) <b>Objective measurements showed several significant differences between two groups.</b>

**Conclusion**

Various voice treatment methods used for teacher with voice complaints. Among vocal hygiene plays an important role in prevention of voice disorders and improvement of vocal quality and self perception of voice. In this paper two main approaches for voice treatment in teachers that contain vocal hygiene were discussed. These two techniques were vocal hygiene program (preventive or indirect method) and vocal educational program (direct method). As mentioned above in indirect method the treatment effect was little and last for few months after treatment but in direct method evidence showed that outcomes were significant and observable for own teachers too. This procedure also had longer effects.

**References**

1. Martin S. and Darnley L. The teaching voice: Whurr Publishers, 2004.
2. Colton R.H., Casper J.K., Leonard R. Understanding Voice Problems: Lippincott Williams and Wilkins, 2011.
3. Bovo R., Galceran M., Petruccelli J. and Hatzopoulos S. Vocal Problems Among Teachers: Evaluation of a Preventive Voice Program. Journal of Voice, 2006; 12(6):705-22.
4. Pizolato R.A., Rehder M.I.B.C., Tadeu dos Santos Dias C., Meneghim M.C., Ambrosano G.M.B., Mialhe F.L. and Pereira A.C. Evaluation of the Effectiveness of a Voice Training Program for Teachers. Journal of Voice, 2013; 27(5):603-10.
5. Roy N., Weinrich B., Gray S.D., Simon M., Dove H., Corbin-Lewis K., Stemple J.C. and Sapienza C.M. Three Treatments for Teachers With Voice Disorders: A Randomized Clinical Trial. Journal of Speech, Language and Hearing Research, 2003; 46:670-88.
6. Hazlett D.E., Duffy O.M. and Moorhead S.A. Review of the Impact of Voice Training on the Vocal Quality of Professional Voice Users: Implications for Vocal Health and Recommendations for Further Research. Journal of Voice, 2009; 25(2):181-91.
7. Barnes-Burroughs K. and Rodriguez M.C. The Teaching Performer: A Survey of Assets Versus Choices in Voice Use. Journal of Voice, 2011; 26(5):642-55.
8. Roy N., Weinrich B., Gray S.D., Tanner K., Walker Toledo S., Dove H., Corbin-Lewis K. and Stemple J.C. Voice Amplification Versus Vocal Hygiene Instruction for Teachers With Voice Disorders: A Treatment Outcomes Study. Journal of Speech, Language, and Hearing Research, 2002; 45:625-38.

9. Pasa G., Oates J. and Dacakis G. The relative effectiveness of vocal hygiene training and vocal function exercises in preventing voice disorders in primary school teachers. *Logopedics Phoniatrics Vocology*, 2007;32: 128-140.
10. Behlau M. and Oliveira G. Vocal hygiene for the voice professional. *Current Opinion in Otolaryngology & Head and Neck Surgery*, 2009;17:149-54.
11. Timmermans B., Vanderwegen J. and De Bod.S. Outcome of vocal hygiene in singers. *Current Opinion in Otolaryngology & Head and Neck Surgery*,2005;13:138-42.
12. Yiu E.M-L. Impact and Prevention of Voice Problems in the Teaching Profession: Embracing the Consumers'View. *Journal of Voice*,2002;16(2):215-28.
13. Chan R.W. K. Does the Voice Improve with Vocal Hygiene Education? A Study of Some Instrumental Voice Measures in a Group of Kindergarten Teachers. *Journal of Voice*,1994;8(3):279-91.
14. Zambon F., Moreti F. and Behlau M. Coping Strategies in Teachers With Vocal Complaint. *Journal of Voice*, 2013;28(3):341-8.
15. Van Houtte E., Claeys S., Wuyts F. and Van Lierde K. The Impact of Voice Disorders Among Teachers: Vocal Complaints, Treatment-Seeking Behavior, Knowledge of Vocal Care, and Voice-Related Absenteeism. *Journal of Voice*, 2010;25(5):570-5.
16. Cantor Cutiva L., Vogel I., Burdorf A. Voice disorders in teachers and their associations with work-related factors: A systematic review. *Journal of Communication Disorders*. 2013;46:143-55.
17. Timmermans B., De Bodt M.S., Wuyts F.L. and Van de Heyning P.H. Analysis and Evaluation of a Voice-Training Program in Future Professional Voice Users. *Journal of Voice*, 2004;19(2):202-10.
18. Timmermans B., De Bodt M.S., Wuyts F.L. and Van de Heyning P.H. Training outcome in future professional voice users after eighteen months voice training. Erasmus Institute Brussels, Department Rits Faculty of Medicine, UA, Belgium. Department of Otolaryngology, Head and Neck Surgery and Communication Disorders.
19. Rodriguez-Parra M.J. , Adrian J.A. , Casado J.C. Comparing voice-therapy and vocal-hygiene treatments in dysphonia using a limited multidimensional evaluation protocol. *Journal of Communication Disorders*,2011; 44: 615-630.
20. Pedrosa V., Pontes A., Pontes P., Behlau M. and Peccin S.M. The Effectiveness of the Comprehensive Voice Rehabilitation Program Compared With the Vocal Function Exercises Method in Behavioral Dysphonia:A Randomized Clinical Trial. *Journal of Voice*,2015.
21. Achey M.A., He M.Z. and Akst L.M. Vocal Hygiene Habits and Vocal Handicap Among Conservatory Students of Classical Singing. *Journal of Voice*,2015.
22. Pedersen M., Beranova A. and Moller S. Dysphonia: medical treatment and a medical voice hygiene advice approach. A prospective randomised pilot study. *Eur Arch Otorhinolaryngol*, 2004;261:312-5.
23. Timmermans B., De Bodt M.S., Wuyts F.L. and Van de Heyning P.H. Voice quality change in future professional voice users after 9 months of voice training. *Eur Arch Otorhinolaryngol*,2004;261:1-5.
24. Yun Y., Kim M. and Son Y. The effect of vocal hygiene education for patients with vocal polyp. *Otolaryngology-Head and Neck Surgery*,2007;137:569-75.
25. Broaddus-Lawrence P.L., Treole K., McCabe R.B., Allen R.L. and Toppin L. The Effects of Preventive Vocal Hygiene Education on the Vocal Hygiene Habits and Perceptual Vocal Characteristics of Training Singers. *Journal Of Voice*,2000;14(1):58-71.
26. Thomas L.B. and Stemple J.C. Voice Therapy: Does Science Support the Art? *Communication Disorders Review*,2007;1(1):49-77.
27. Pizolato R.A., Rehder M.I.B.C., Tadeu dos Santos Dias C., Meneghim M.C., Ambrosano G.M.B., Mialhe F.L. and Pereira A.C. Impact on quality of life in teachers after educational actions for prevention of voice disorders: a longitudinal study. *Health and Quality of Life Outcomes*,2013;11(28).
28. Sataloff R.T. *Vocal Health and Pedagogy Volume 2: Advanced Assessment and Practice*: Plural Publishing,Inc; 2006.

29. Hackworth RS. The effect of vocal hygiene and behavior modification instruction on the self-reported vocal health habits of public school music teachers. *International Journal of Music Education*,2007;25(1).
30. Behrman A., Rutledge J., Hembree A. and Sheridan S. Vocal Hygiene Education, Voice Production Therapy, and the Role of Patient Adherence: A Treatment Effectiveness Study in Women With Phonotrauma,2008;51:350-66.
31. Nanjundeswaran C., Li N.Y.K., Chan K.M.K., Wong R.K.S., Yiu E.M.L. and Verdolini-Abbott K. Preliminary Data on Prevention and Treatment of Voice Problems in Student Teachers. *Journal of Voice*,2012;26(6).
32. Bovo R., Trevisi P., Emanuelli E. and Martini A. Voice Amplification For Primary School Teachers With Voice Disorders: A Randomized Clinical Trial. *International Journal of Occupational Medicine and Environmental Health*,2013;26(3):363 – 72.
33. Roy N., Gray S.D., Simon M., Dove H., Corbin-Lewis K. and Stemple J.C. An Evaluation of the Effects of Two Treatment Approaches for Teachers With Voice Disorders: A Prospective Randomized Clinical Trial. *Journal of Speech, Language, and Hearing Research*, 2001;44:286-96.
34. Gillivan-Murphy P., Drinnan M.J., O'Dwyer T.P., Ridha H. and Carding P. The Effectiveness of a Voice Treatment Approach for Teachers With Self-Reported Voice Problems. *Journal of Voice*,2005;20(3):423-31.
35. Faham M., Ahmadi A., Drinnan M., Saadatmand N., Fatahi E. and Jalalipour M. The Effects of a Voice Education Program on VHI Scores of Elementary School Teachers. *Journal of Voice*,2015.
36. Duffy O.M. and Hazlett D.E. The Impact of Preventive Voice Care Programs for Training Teachers: A Longitudinal Study. *Journal of Voice*,2003;18(1).
37. Richter B., Nusseck M., Spahn C. and Echternach M. Effectiveness of a Voice Training Program for Student Teachers on Vocal Health. *Journal of Voice*,2015.
38. Timmermans B., Coveliers Y., Meeus W., Vandenabeele F., Van Looy L. and Wuyts F. The Effect of a Short Voice Training Program in Future Teachers. *Journal of Voice*,2010;25(4):191-8.
39. Timmermans B., Coveliers Y., Wuyts F.L. and Van Looy L. Voice Training in Teacher Education: The Effect of Adding an Individualized Microteaching Session of 30 Minutes to the Regular 6-Hour Voice Training Program. *Journal of Voice*,2011;26(5).

## An Analysis of Translation Strategies in the Persian Translation of Woody Allen and Fernando Sorrentina's Comic Stories Adopted by Hossein Yaghoobi

Mehri Farzaneh <sup>a</sup>, Mostafa Movahed, Zahra Yazdani Zadeh

<sup>a</sup>Faculty member of Payame Noor University, Isfahan, Iran  
Instructor of Payam Noor University, Isfahan, Iran

### Abstract

In translating comic expressions, a translator should be able to preserve the imaginative pleasure and emotional impacts without damaging the exact meaning. This principle is important for the purpose of conveying the message of the source text to the target text in a way that helps audience make sense of the product (translation). Therefore, every translator needs to have a good command of both languages and cultures being translated as well as knowledge about how to cope with different translation strategies in translating comic expressions. The present study is a descriptive qualitative research that aimed to explore and describe the translation techniques used in translating comic stories written by Woody Allen and Fernando Sorrentina translated by Hossein Yaghoobi. To this end, six stories of the book were selected as the source data. This study employed two stages of analysis, that is, domain and taxonomic analyses. In the domain analysis, comic translations from the book were identified, evaluated, and verified. In performing the taxonomic analysis, the 5 translation techniques namely adaptation/cultural equivalent, amplification/addition, condensation/reduction, modulation, and transposition proposed by Newmark(1982), Panek(2009), and Molina & Albir (2002) applied in the translation of the selected comic expressions were identified and discussed. Based on the analysis of the results, the procedures with a higher rate of use were amplification (37%), adaptation (25%), and modulation (22%). The strategies with a lower rate of application, however, were condensation (9%) and transposition (7%). Besides, the most frequently used strategy in comic translation was amplification, however, the least frequently used strategy was transposition..

**Keywords:** comic translation, strategy, source text, target, translator

### Introduction

Translation consists of transferring the meaning of the source language into the receptor language by going from the form of the first language to the form of a second language by way of semantic structure in which meaning must be held constant(Larson,1984:3).Newmark(1982:7) defines translation as a craft consisting in an attempt to replace a written message or statement in one language by the same message or statement in another language .Because the role of translator is to keep the meaning constant , whenever necessary, the receptor language form should be changed in order that the source language meaning not be distorted(Larson,1984:11).Translator plays an important role as a bilingual or multi-lingual cross- cultural transmitter of culture and truths by attempting to interpret concepts and speech in a variety of texts as faithfully and accurately as possible(Gerding , 2000).There have been many different texts which are translated from one language into another language such as religouse, history, psychology ,literature and so on. One kind of literary text is humour.The term " humour" itself originated from Latin word " umor" meaning fluid and was used as a medical term(Chiaro,2010:13).Chiaro states that today's humor is an " umbrella term" that covers such concepts as " comedy" , " fun" , " ridiculous" and more( Chiaro ,2010:14).Dudden (1987:7) remarks that humour to the anthropologist is " a determined because the sociological factors are the primary mechanism leading to its occurrence".According to Vandaele:" humour translation is qualitatively different from " other types " of translation and , consequently, one can not write about humour translation in the same way one writes about other types of translation"(Vandaele,2002:150). Considering the complicity , Chiaro compares translation of poetry with translation of humour and states that " humour easily wins the first prize"(Chiaro,2010:21).Humour

becomes “untranslatable” simply because “ an adequate degree of equivalence is hard to achieve”( Chiaro,2010:8).According to Molina and Albir,(2002) there are 18 translation techniques : aptation,amplification,borrowing,calque,compensation,description,discursive creation,established equivalent, generalization, linguistic amplification, linguistic compression, literal translation , modulation ,particularization, reduction, transposition, substitution and variation. For translating humour texts ,Panek ,M(2009) introduces some strategies which are condensation, decimation, deletion ,paraphrasing, neologism, transposition, modulation, substitution and literal translation .The aim of this study is to identify techniques and strategies which are applied for translating humour texts.To this end we refer to Newmark ,(1988 ) and Molina & Albir, (2002 )strategies of translation in general and Panek ,(2009) techniques of humour translation in specific

### Literature Review

Humor is one of the important aspects of humanity It is an integral part of everyday communication and it is a literary works. Humor translation is said to “present some extra difficulties not encountered in translating straight referential prose and compare with the difficulties faced in the translation of poetry” Chiaro,( 1992). Humor is also considered as “one of the specific textual aspects which pose the greatest challenge to the translator, and which test the process of decision making to the full” (Sousa, 2002). Different definitions of translation are told by many translators. Newmark ,(1982: 7) defines translation as a craft consisting in an attempt to replace a written message or statement in one language by the same message or statement in another language. Larson, (1984: 3) defines translation as a process of transferring the meaning of the Source Language (called SL henceforth) into the Target Language (called TL henceforth), which is the language of the receptors, by retaining the SL and changing its forms. Translation process involves the perspectives of formal equivalence which represents the closest equivalent in terms of meaning and styles of both the SL and TL.At last , translation is transferring the meaning of written or spoken language into their closest equivalent written or spoken language.Translation is a complicated process.The translator moves back and forth from the source text to the target text .In translating, Newmark ,(1988:144) mentions that there are basic translation processes. Those are:

- The interpretation and analysis of the SL text :This explains the reason for interpretation of the translator on the text is. A translator should be someone who has experience in the message he wants to transform or at least, he processes adequate knowledge.
- The translation procedure :This process “may direct”, or the basis of SL and TL corresponding syntactic structure, or through an underlying language “inter language”.
- The reformulation of text :In this point, the process has to be in accordance with the writer’s ideas of intention, the reader’s curious wish, the proper form of TL and so on.

The categories used to analyze translations allow us to study the way translation works .These categories are related to text ,context and process. Textual categories describe mechanisms of coherence ,cohesion and thematic progression.Newmark ,(1988:144) also divided the translation procedure many types . We discuss on some strategies that applied in this study .They are as follows:cultural Translation : This is an approximate translation where an SL culture word is translated by TL cultural word. Shift or transpositions : A “shift” or “transportation” is a translation procedure involving a change in the grammar from SL to TL.Modulation : Modulation define “a variation through a change of viewpoint, of perspective and very often of category of thought”. Free modulation are used by translator when target language rejects literal translation. Compensation : This procedure occurs when loss of meaning, sound effect metaphor or pragmatic effect in one part of a sentence is compensated in another part.Reduction and expansion : In this type, a translator has to change the system of the translation work from the original one to obtain the most appropriate translation result to find out the closest equivalent in TL Newmark, (1988:56).Amplification: explanation of the meaning of a segment of

the text. It is used in an „anonymous“ text when it is poorly written, or has important implications or omissions Newmark, (1988, p.90).

Molina & Albir, (2002) suggested 18 translation techniques. Some of the techniques is considered in this study are as follows : Adaptation : Molina & Albir, (2002: 500) define adaptation as replacing a cultural element in a SL text with the one originating from TL culture which makes the translation of the original more familiar in the TL. According to Hatim & Munday, (2004: 151), adaptation is used in those cases where the type of situation being referred to by the SL message is unknown in the TL culture. Therefore, the translator has to create a new situation that can be considered as being equivalent. Amplification : Molina & Albir, (2002: 500) define amplification as the technique applied by adding or introducing information item that is not present in the SL text. This technique can be used to provide necessary additional information. Amplification occurs when the TL uses more signifiers to cover syntactical or lexical gaps. Compensation : Molina & Albir (2002: 500) explain that compensation takes place when an item of information or a stylistic effect from the ST that cannot be reproduced in the same place in the TT is introduced elsewhere in the TT. Modulation : Hatim & Munday, (2004: 150) define modulation as a variation of the form of the message obtained by a change in point of view when literal or transposed translation results in a grammatically correct utterance or is considered unsuitable, unidiomatic, or awkward in the TL. Molina & Albir ,(2002: 510) specify that it changes the point of view, focus, or cognitive category in relation to the ST which can be either lexical or structural. Reduction : Molina & Albir ,(2002: 510) define reduction as suppressing or reducing information item found in the SL so that it does not appear in the TL. Transposition :Molina & Albir, (2002: 511) define transposition as changing the grammatical category. Budiharjo & Minggus (2016: 103) specify that transposition means translating units of translation by applying changes in grammatical category, because of the difference between the grammar of the SL and that of the TL.

**3.METHODOLOGY**

To study the strategies used to translate comic expressions, as practiced by Yaghoobi Hossein, a well-known Iranian translator, a careful proximity of the source language (English) sentences and the respective Persian translation of the intended sentences was created. Of the total sentences contained in these stories, 100 comic phrases or sentences were extracted and classified based on the application of translation techniques These technique are: adaptation/cultural equivalent, amplification/addition, condensation/reduction, modulation, and transposition of Newmark, (1981),Panek ,(2002),Molina and Albir , (2002) .To carry out the study six stories of woodyallen and Fernando Sorrentino were chosen as the main sources.Hoseein yaghoobi ,in his book titles “ Harjo Marj-e Mahz” has translated these stories The number and percentage of each strategy practiced by translator was measured and put into a table. Then, to analyze the strategies used in the translation of the so-called sentences and phrases, a qualitative and descriptive analysis was carried out by the researchers.The frequencies and percentages of each translation technique applied by Yaghoobi Hossein in the translation of the comic stories of Woody Allen and Fernando Sorrentina are given in Table 3.1.

3.1.Tables .Number and percentage of translation methods used in the translation of the comic stories of Woody Allen and Fernando Sorrentina

Transla tion method	Adaption/c ultural equivalent	Amplifi cation /additio n	Condens ation/ reductio n	modula tion	transpos ition
number	25	37	9	22	7
percent age	%25	%37	%9	%22	%7

As it is observed in the above table amplification, adaptation, and modulation were the most frequently used techniques in Yaghoobi's translation. The table also reveals that compensation was the



least frequently used strategy with 2-time occurrence (2%). It seems that compensation has little use in transmission of comic mode and the translator has preferred to use this technique less than the other techniques.

**4. RESULT AND DISCUSSION**

**4.1. Amplification/Addition**

In amplification, the translator adds more details or words to a SL information item in the TL text, mainly to express the same idea. The analysis of the data shows that amplification is the most frequently occurring technique (37%) in the group of techniques. This over-use of amplification technique may be due to translator’s preference for descriptions of details that are not expressed in the SL. It seems that the translator does really know what these comic terms imply or denote, but cannot find an equivalent term in the TL, or actually, there is no equivalent term in the TL, so he tends to describe them. Table 4.1.1. shows three randomly chosen examples of this type of translation.

*4.1.1. Table. Samples of amplification translation strategy adopted by Yaghoobi*

Source Texts	Target Texts
This wretch who had made me miss my siesta.	mardake tarsoo <b>mesle khoroose bi mahal</b> chorte baad az zohre mara pare kard.
my point of view won out	belakhare harfe manteghie man <b>be korsi neshast.</b>
you don’t understand these matters	chand dafe behet goftam <b>halo to in chiza ro nemigiri</b>

aking a look at English and Persian version of sentence (3) indicates the words "chand dafe" and "halo" have been added to the Persian translation in order to make the translation more intelligible and humorous for the Persian readers.

**4.2. Adaptation/Cultural equivalent**

As it is observed in table 1, the frequency of adaptation in Yaghoobi's translation is also high (25%). The following table illustrates some examples of this approach.

*4.2.1. Table Samples of adaptation translation strategy adopted by Yaghoobi*

Source Texts	Target Texts
My wife watched an endless television program	hamsaram yek seriale darepite television negah mikard.
Whenever I feel like it	harvaght eshgham bekeshad.
I must go	az khedmateton morakhas mishavam.

According to New Mark, (1988) adaptation, also known as cultural equivalent, is a shift in cultural element where the translator expresses cultural realities of the original text in a quite different way that is familiar or better suited to the culture of the target language. This mostly achieves a more familiar and intelligible text. A simple example would be translating “Whenever I feel like it ” from English into Persian. In this case the translator would need to adapt the translation to the cultural reality of the Persian-speaking world and translate it as “harvaght eshgham bekeshad ”In this example, “I feel like it”

has been translated as "eshgham bekeshad" Most Iranian people know what is "eshgham bekeshad", thus the translator has preferred to adapt or domesticate the translation in a way that conveys the same result as in the source-text and have a similar effect on the TL readers.

#### 4.3. Modulation

The results of this study demonstrate that modulation is another translation technique that has widely been used in by the translator (22%). The following table presents some specific examples of this strategy.

4.3.1. Table : Samples of modulation translation strategy adopted by Yaghoobi

Source Texts	Target Texts
A sprig of parsley	Ashghal sabzi
How the devil do you have the nerve to walk into my house	mage khoneye mardom tavile ast ke hamintor saretono mindazid paeen o miaed too.
I missed slept with my clothes on	bedone inke hata sham bokhoram o lebasamo avaz konam roye takht az hosh raftam.

According to Molina, (2002) modulation basically means using a phrase that is different in the source and target languages to convey the same idea. In other words, modulation helps the translator generate a change in the point of view or perspective of the message Munday,( 2008), p. 57; Molina & Albir,) without altering its meaning and without generating an unnatural feeling in the reader of the target text. which can occur not only on the word level but also on the phrase, clause and sentence level (Barth, 1971, p. 41). Here's an example of modulation in translating from English to Persian: How the devil do you have the nerve to walk into my house?

"mage khoneye mardom tavile ast ke hamintor saretono mindazid paeen o miaed too"

In the light of the above example(s) one may infer that the translator has tried to avoid lack of fluency or exoticism in the translation and convince the Persian readers that they are not reading a translation, but an original text. Obviously, providing such a translation requires an excellent knowledge of both languages (English and Persian) involved in the translation, and the translator has benefited well from this knowledge.

#### 4.4. Condensation

Based on the results illustrated in table 1, condensation was applied 9 times (9%). Table 5 illustrates some examples of this approach.

4.4.1. Table : Samples of condensation translation strategy adopted by Yaghoobi

Source Texts	Target Texts
The animal slipped up his pants leg between the leg and the pants	ankabot be sorat az roye kafsh varede pacheye shalvaresh ahod va az pash bala raft
To imagine the frenzied state of nervousness and excitation with which I was seized	mitavanand hads bezanand ke man aan roz zohr che hali dashtam
A receptionist with a rear end you can't keep your eyes off	yek monshie to del boro

An example of this procedure could be the following one: A receptionist with a rear end you can't keep your eyes off " yek monshie to del boro"

According to Panek, (2009), in condensation the translator suppresses a SL information item in the TL text, mainly when that information is considered unnecessary. The above presented translation indicates that the phrase 'with a rear end', in the SL sentence has been omitted from the TL text because the phrase seems to be redundant and unnecessary from the point of view of the translator. Obviously, It is the role of the experienced translator to decide which elements are redundant and can be deleted. The reasons behind such deletions are not clear, but probably the main reason of employing such a strategy in translation is its simplicity whereby the translator decides to transform a long and complex sentence in the SL into a short one in the TL. According to Zhao, (2016), this strategy is especially beneficial for children's literature translation, whose readers are children with incomplete cognitive level and limited vocabulary.

**4.5. Transposition**

Another technique used by the translator is transposition, which is defined as changing the grammatical category of the SL and that of the TL (Makaryk,1993; Molina & Albir.( 2002); Megerdoomian ,(2017) . Table 6 illustrates some special examples of transposition.

4.5.1. Table: Samples of transposition translation strategy adapted by Yaghoobi

Source Texts	Target Texts
Presumed insanity	divaneyeye mashang
I'd waken integrate mood with a rosy outlook on	sarhalo sarzende az takhtekhab boland shodam
Blinded momentarily by arrogance .I honestly believed .I could easily crush him against the wood of baseboard with my shoe	qorore kazeb baraye yek lahze cheshme basirate mara koor kard.

These examples clearly show how morphological or syntactic categories of the SL (English) have been changed in the TL (Persian).According to Megerdoomian (2017), grammatical transpositions, with appropriate morphological and syntactic adjustments, are quite frequent in order to obtain a translation that sounds as if it had been originally written in the TL.

**5.CONCLUSION**

The current study is a descriptive qualitative research that aims to identify the translation strategies used in translating comic stories of Woody Allen and Fernando Sorentino translated by Hossein Yaghoobi in his book titled Harj-o -Marj-e -Mahz .After collecting and analyzing data ,it has been concluded that modulation, transposition , condensation ,amplification and adaptation have been used by the translator . Based on the analyses of the results the most frequently used translation strategy was amplification with the occurrence of 37 times (%37). The least frequently used strategy , however , was transposition with 7-time occurrence (%7)

5.1. Figure : The percentage of applied strategies in translator's work

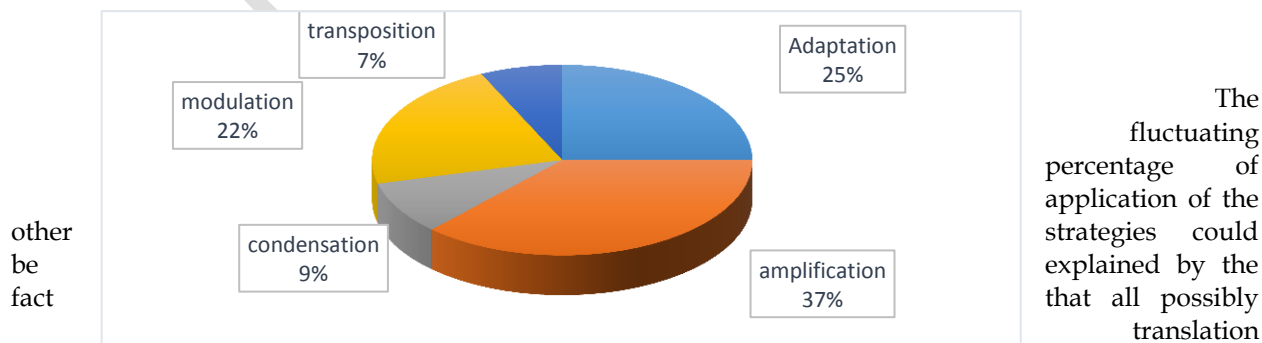

strategies can not be equally applied to comic expressions .

**An example appendix**

Appendix 1

CONDENSATION/REDUCTION:

I could easily crush him <b>against the wood of baseboard with my shoes.</b>	fekr mikardam ke mitavanam ba yek zarbe lenge kafsh kalakash ra bekanam va amadeye zarbe shodam.
The animal slipped up his pants leg <b>between leg and the pants.</b>	ankabot be sorat az roye kafsh varede pacheye shalvareh ahod va az pash bala raft
<b>Knock it the floor</b> and then kill it , catch it.	ba zarabate kari khedmatash beresad.
I was only looking for something simple ,catchy popular songs, <b>half time tunes, television jingles.</b>	faqat mokhastam yek ringe bazari va yek ahange aame pasand benavazam
The sudden image of Maria Alejandra afflicted me with the first feelings of remorse in four years.	baad nakhodagah dochare azaabe vejdan ham shodam.
To imagine the frenzied state of nervousness and excitation with which I was seized .	mitavanand hads bezanand ke man aan rooz zohr che halo rozi dashtam
A receptionist with a rear end you can't keep your eyes off .	yek monshie too del boro
The largest denomination in circulation.	eskenase dorosht
Not too long novel	romanak

Appendix 2

MODULATION:

I have <b>common sense</b> enough.	Age man khodam ye moqe <b>kharyat nakonam</b>
Never again would I dare <b>harm</b> him.	jorat nemikardam be joonesh <b>soe qasd konam</b>
<b>The full strength</b> toxic type	az noe qavi <b>va filkosh</b>
<b>This wretch</b>	<b>mardake tarsoo</b>
I'd awaken in great mood <b>with a rosy outlook on life</b>	<b>Sare halo sarzende</b> az takhtekhab boland mishavam
<b>My point of view</b> won out.	Harfe <b>manteqie</b> man be korsi neshast

I missed <b>slept</b> with my clothes on.	bedone inke hata sham bokhoram o lebasamo avaz konam roye takht az hosh raftam.
I <b>get</b> to your city now and again.	bazi vaqta be shahreton <b>saraki mikesham</b>
<b>Is bonkers</b> about drinking lots of water	be nooshidane meqdare ziadi aab dar rooz <b>gir dade</b>
He'll <b>do</b> right by your pocket	ou monasebe bodjeat barat ye lebase dorosto hesabi <b>joor mikone</b>
He said <b>to keep a keen eye out for</b> Mr. Binky Peplum.	behem goft ke biam inja va be binki piplim begam ou <b>mara ferestade</b>
<b>Simple</b> fabrics	parcheye <b>khoshko khali</b>
<b>My bad faith</b>	<b>lezate zire posti</b>
to such and such <b>a place</b>	<b>be folano folane tamame mosafere mohtaram</b>
A sprig of parsley	<b>ashqal sabzi</b>
I missed slept with <b>my clothes on</b>	bedone inke hata sham bokhoram o lebasamo avaz konam roye takht az hosh raftam.
How the devil do you have the nerve to walk into my house	mage khoneye mardom tavile ast ke hamintor saretono mindazid paeen o miaed too
money must change hands	<b>pool harfe avalo mizane</b>
hear himself	<b>nedaye daroon</b>
his face like a thunder cloud	sarzaneshhayash ra shoro kard
Dmitri Simininov just because of this?	<b>demitry simnoto dige dari kheili in qazie ro gonde mikoni</b>
<b>Renowed investment</b> banker failed <b>to get</b> his son into a kindergarten of ample distinction	<b>bankdare khar pool az familhaye dooremon be har dari zad natavanest baraye pesare 5 salah az yek mahde koodake dorosto hesabi paziresh begirad</b>
He as a <b>hopless</b> drunkard	<b>yek dayemolkhamre avazie dozd</b>
Knock it to the floor and <b>kill it,catch it</b>	ba zarabate kari khedmatesh resid

Appendix 3  
**AMPLIFICATION/ADDITION**

were he to consider it	khodaae nakarde yek moqe maslahat bedone ke
------------------------	---

In the morning he enjoys on <b>examination</b> of house perhaps without set purpose	sobha doost dare noqate mokhtalef va bekre khone ro kashf kone
I could easily <b>crush</b> him against the wood of baseboard with my shoes	Ba yek zarbeye lenge kafsh kalakesho bekanam va amadeye zarbe shodam
The mosquito was thinking, meditating , deliberating	pashe balaye saram hamchenan dasht janbehaye mokhtalefe in eqdame teroristie mara misanjid
eyes full of tears	cheshmaye por az ashk)bavar konid 2kase khon)
I also have <b>one hope</b>	omidvaram ke belakhare ezraeele pasheha , fereshteye nejate man bashad
I'm not very sociable	kasani ke mara mishenasan midanand man kheili aadame ejtemaee va ahle moasherati nistam
spider on his <b>right</b> shoes	ankaboote doroshti rooye sagake kafshe paye rastesh
Enrique Viani was “ petrified “	az shedate tars dar maaraze zahre tarak shodan bood
afraid of getting stung	ou be hich onvan hazer nabood khatare gazide shodan ra be jan bekharad
he stood <b>immobile</b>	anrik dorost mesle mojasame bi hareket kenare balkon istade bood
my <b>plan</b> was perfect	naqsheye hooshmandane va kamele man harf nadasht
this wretch who had made me miss my siesta	mardake tarsoo mesle khoroose bi mahal chorte badazohre mara pare karde bood
afraid of getting stung	ou be hich onvan hazer nabood khatare gazide shodan ra be jan bekharad
Monday I'll buy something decent -looking	2shanbeha ke maqaze baz beshavad yek chize dorosto hesabio aaberomandene vase tazeenesh mikharam
she's back from work	khaste va koofte az sare kar bargashtam
The man who wouldn't let me play my horn had taken possession of my soul	raeesi ke be man ejaze nadahad sheypooram ra bezanam dar haqiqat pardedare saffaki ast ke roohe mara taskhir karde va be zanjir keshide ast
I love the horn , I fear dismissal	avail yadavari mikard cheqadr asheqe navakhtan ba sheypoore hastam va dovomi nahib mizad ke cheqadr az ekhraje mahale karam mitarsam
my point of view won out	belakhare harfe manteqie man be korsi neshast
my sour-faced wife	mesle borje zahremar ba chehreye darham
You are a man who deposits a vast amount of ichor on your clothing	az oun daste adamhaye shelakhtee hasti ki hesabi roye lebasat kesafat kari mikoni
new situation	

	sharayeti motafavet va qafelgir konande
I study his anger at my <b>bad faith</b> his disappointment at the foiled rip-off	ba lezate zirpoosti khashmo parishani ke dar aane vahed geribangire nanva shode mibinam va keyf mikonam
I drop a chess rook and a sprig of parsley into it .	<b>yek daste ashqal sabzi ya khoraki ra ke az qabl amade kardam kafe dastesh migzaram</b>
you don't understand these matters	chand dafe behet goftam halo to in chiza ro nemigiri
you are such a bumpkin	to yek dehatie sade lohi va hichvaqt aadam nemishi
I greased everybody	man be hame pool dadam va ham era kharidam
failed to get his son into kindergarten	be har dari zad natavanest bacheash ra be mahde koodak bebarad.
Threadbore	zhakat o shalvare bonjol
landlady	sahebkhaneye pirezane kenese pooldar
dismemberment	ba tabar teke teke kard
I am going to write this note in the first person	in latlab be shekel aval shakhse va danaye motlaq minevisam
As worthy men have said	<b>bar asase edeaaye bazi shohood va karshenasane motabar</b>
I like reading more than writing and in fact I don't write too much	haqiqatash ra belhahid man khandan ra be neveshtan tarjih midaham va babate hamin kheili neminevisam
After thirty two years	ba tavajo be inke 32 salas minevisam
I have been translated into the following languages	Ke dastanhayam be 25 zabane zende v anime jan chap shode ast
As with anybody else	<b>mesle baqie nevisandeha</b>

Appendix 4  
TRANSPOSITION

blinded momentarily by arrogance	qorore kazez baraye 1 lahze cheshme basirate mara koor kard
<b>I'd awaken</b> in great mood with a rosy outlook on life	sarehalo sarzende az takhtekhab boland mishavam
The man who whouldnt let me play my horn had <b>taken</b> possession of my soul	raeesi ke be man ejaze nadahad sheypooram ra bezanam dar haqiqat pardedare saffaki ast ke

	roohe mara taskhir karde va be zanjir keshide ast
my wife <b>watched</b> on endless television program	hamsaram 1 seryale dare pite television negah mikard
medical profession <b>is bonkers</b> about drinking lots of water	elme pezeshki be masaleyeh nooshidane meqdare ziadi aab dar rooz gir dade
presumed insanity	divaneye mashang

Appendix 5  
ADAPTATION/ CULTURAL EQUIVALENCE

<b>To my great good fortune</b>	shokre khoda
As noiselessly as possible	pavarchin
I swear by every thing mostly I'll never try it again	Be hameye chizaye moqadase khodato khodan qasam mikhoram dige hamchin qalati nakonam
Enrique Viani was "petrified"	az shedate tars dar maraze zahre tarak shodan bood
make a vertical slit downwards in his pants leg	ba yek boresh kheshtake shalvarash ra yek teke dar miavarad
My plan was perfect	naqsheye hooshmandane va kamele man harf nadasht
this wretch who had made me miss my siesta	mardake tarsoo mesle khoroose bi mahal chorte badazohre mara pare karde bood
She only complicated my life anyway	ou zendegie man ra az in chizi ke bood gando gohtar mikard
I was only looking for something simple catchy	faqat mikhastam yek ringe bazari benavazan
the poor kid	heyvanaki
She must be tired and bored to death with the routine of her job	baad az 1 rooze khaste konande va tekrari bayad kheyli halash gerefte shode bashad
my point of view won out	belakhare harfe manteqie man be korsi neshast
My wife watched an endless television program	hamsaram 1 seryale dare pite television negah mikard
Whenever I feel like it a gaming crony	harvaqt eshqam bekeshad
threadbore	rafiqe garmabe va golestan zhakato shalvare bonjol
slander	matalake nishdar
I wanted to impale him on a pike	doost dashtam gardanash ra beshkanam
lager	aab shangooli
Sauces and ointment	charbo chili



unmotivated well-being	alaki khosh be halam shod
I must go	az khedmateton morkhas mishm
chess rook	<b>khoraki</b>
alcohol	<b>'aab shangoli</b>

### Reference

- Barth, G. (1971) French to English: Some stylistic considerations. *Meta: Translator's Journal*, 16(1-2).
- Budiharjo, B. & Minggu, (2016) ,L.. *Decision Making in Translation and Its Consequence: The Impact of Translation Techniques on the Quality* (the 5th ELTLT International Conference Proceedings, October 2016). UNNES
- Chiaro D. et al, (2010) *Translation Humor and Literature* , London.
- Chiaro, D (1992). *The language of jokes: Analysing verbal play*. London: Routledge.
- Dudden ,A. PEast ,(1987)- *elements containing humor* . Unpublished PhD Thesis, Waroclaw University , Poland West Journal .Vol.2 No .1:3-16.
- Gerding S ,( 2000), Constanza Teaching Translation :Problem and Solutions. *Translation Journal* 3(2) 34-35..
- Hatim B. & Munday J, ( 2004). *Translation: An Advanced Resource Book*. New York: Routledge Taylor and Francis Group.
- Karine Megerdoomian, (2017)., . " Persian Computational Linguistics." *Oxford Handbook of Persian Linguistics*. Ed. Anousha Sedighi and Pouneh Shabani-Jadidi. : Oxford University Press,
- Larson M, (1984). *Meaning -Based Translation: A Guide to Cross - Language Equivalence* . London University Press of America.
- Makaryk, Irena R ,( 1993 )" *Encyclopedia of Contemporary Literary Theory: Approaches, Scholars, Terms*" University of Toronto Press,
- Molina L. & Albir A.H, ( 2002) . *Translation Techniques Revisited: A Dynamic and Functionalist Approach* (META Translator's Journal Vol. 47. No. 2
- Munday, J, (2008). *Introducing translation studies: Theories and applications*. London and New York Newmark , P, (1982) . *Approaches to Translation* . Oxford : Pergamon Press..
- Newmark, P, (1988). *A textbook of translation*, London: Prentice Hall International.
- Panek, M (2009) . *Subtitling Humor: The analysis of selected translation techniques in subtitling* .)
- Sousa, C, (2002). TL versus SL implied reader: Assessing receptivity when translating children's literature. *Meta: Translators' Journal*, XLVII(1), ( 2002). Retrieved 3 February 2009 from <http://id.erudit.org/iderudit/007988ar V>.
- Vandeale , J., (2002) " In: *The Translator* , Volume 8, Number 2 , pp. 149-172.
- Zhao, Yushan ,(2016). *The Application of Gestalt Simplicity Principle in Translation of Charlotte's Web*: Vol 12, No 1 , *Studies in Literature and Language*.

### References

- Van der Geer, J., Hanraads, J. A. J., & Lupton, R. A. (2000). The art of writing a scientific article. *Journal of Science Communication*, 163, 51-59.
- Strunk, W., Jr., & White, E. B. (1979). *The elements of style* (3rd ed.). New York: MacMillan.
- Mettam, G. R., & Adams, L. B. (1999). How to prepare an electronic version of your article. In B. S. Jones & R. Z. Smith (Eds.), *Introduction to the electronic age* (pp. 281-304). New York: E-Publishing Inc.
- Fachinger, J., den Exter, M., Grambow, B., Holgerson, S., Landesmann, C., Titov, M., et al. (2004). Behavior of spent HTR fuel elements in aquatic phases of repository host rock formations, 2nd International Topical Meeting on High Temperature Reactor Technology. Beijing, China, paper #B08.

Fachinger, J. (2006). Behavior of HTR fuel elements in aquatic phases of repository host rock formations. *Nuclear Engineering & Design*, 236, 54.

ACCEPTED

## The Effect of Age at Implant on the Vowel Space of Cochlear Implanted Children

Seyede Zahra Asghari<sup>a</sup>, Fatemeh Nemati<sup>b</sup>, Rezvan Akbari Manie<sup>c</sup>, Farzaneh Esna-Ashari<sup>d</sup>, Farhad Farahani<sup>e</sup>

<sup>a</sup>Assistant Professor, Department of Language, School of Medicine, Hamadan University of Medical Sciences, Hamadan, Iran

<sup>b</sup>Assistant Professor, Department of English Language and Literature, Persian Gulf University, Bushehr 7516913817, Iran

<sup>c</sup>PhD Student of Language and Speech Therapy, Tehran University of Medical Sciences, Tehran, Iran

<sup>d</sup>MD, Associate Professor, Department of Community Medicine, School of Medicine, Hamadan University of Medical Sciences, Hamadan, Iran.

<sup>e</sup>MD, Full professor, Department of Otorhinolaryngology, School of Medicine, Hamadan University of Medical Sciences, Hamadan, Iran.

### Abstract

Vowel space as the objective representation of vowel articulation, indicates the vowel distinction abilities of speakers. Vowel space formation is dependent on the auditory feedback, hence its compressed nature in hearing-impaired individuals compared with normal-hearing listeners. This study aims at determining the effect of age at cochlear implantation, as a gateway to auditory feedback access, on listeners' vowel space. Acoustic characteristics of all the six Persian vowels produced by two groups of cochlear implanted (CI) children, those receiving cochlear implant before three years (CI<3) and those after three years (CI>3), were analyzed and compared with each other as well as to the productions of an age-matched group of normal-hearing children (NH). Kruskal-wallis test was used to compare differences between the groups and the significance level was set at 5%. Although the vowel space of both CI groups was smaller than age-matched NH children, the difference was only significant between CI>3 and NH children. CI children formed back vowels more front than their normal places of articulation. This feature was more observable in children who had received cochlear implantation at an older age, and indicated that surgery at a younger age had positive effects on recognizing vowels' place of articulation. Regarding height, represented by the F1 of vowels, CI children articulated the vowels higher and accordingly more open than their NH peers. The cause seemed to be the open mouth of trainers while articulating vowels to show the exact place of articulation to CI children. Aside from F1 or the vowel space height in two groups of CI children that seems to be caused by the local condition of exaggerated training, the horizontal lines of CI children's vowel space confirms that earlier implantation causes near normal vowel spaces.

**Keywords:** vowel space, cochlear implanted children, cochlear implantation, hearing impairment, Persian vowels

### Introduction

Cochlear implantation has been performed for about 35 years to benefit patients with severe to profound hearing loss by providing access to auditory feedback of which they might have been deprived of prelingually at birth or postlingually later in life due to accidents and strokes. There is an overall consensus on cochlear implantation being advantageous for the hearing-impaired listeners and it is regarded as one of the most preferred main treatments (Seifert et al., 2002; Neumeyer, Harrington, & Draxler, 2010; Jafari, Yadegari, & Jalaie, 2016). Lots of studies have compared the language ability of CI listeners with those who have used conventional hearing aids (HA) and/or normal hearing (NH) listeners. They have generally reported that this intervention has resulted in a noticeable improvement in the performance of CI users compared to HA users and a similar or, at least closer, performance of them to NH listeners (Geers, Tobey, Moog, & Brenner, 2008; Paatsch, Blamey, Sarant, & Bow, 2006; Moog, 2002; Baudonck, D'haeseleer, Dhooge, & Van Lierde, 2011; McConkey, Svirsky, & Iler Kirk, 1997).

To have a better social life, not only do CI listeners need to accurately perceive sounds, but also they should be able to articulate their speech intelligibly for a successful communication. McConkey et al. (1997) realized that cochlear implant not only enhanced speech perception and speech intelligibility, but also improved the rate of language development significantly. However, the absolute gap between the language skills of CI users and NH listeners remained the same. The differential between the two groups of listeners might be due to the accurate production of speech segments. CI children have shown shortcomings in segment production stability after two years of device use (Ertmer and Goffman, 2011) and the accuracy of their productions have been reported by Tobey, Geers, Brenner, Altuna, and Gabbert (2003) to be 62% and 68% for vowels and consonants after 5.5 years of CI usage. Given that vowels qualities can be studied more objectively through acoustic analysis, some recent studies have focused on the vowel space of HA, CI and NH listeners (e.g. Harnsberger, 2001; Neumeier, Haarrington, Draxler, 2010; Baudonck, Van Lierde, Dhooge, Corthals, 2011). Vowel space, F1/F2 ratio, is both the objective representation of the accuracy of vowel articulation and the main acoustic cue in auditory perception for listeners (Ladefoged & Johnson, 2010; Ladefoged & Disner, 2012). If, in comparison to HA listeners, CI users' vowel space resembles or is closer to that of NH listeners, the produced vowels will be perceived properly by listeners which is one of the constitutive factors in successful communication. In spite of controversies over the effect of implantation on accurate production of vowels, the trend in most studies demonstrates the positive effect of cochlear implant on learning the voice characteristics of vowels (e.g. Uchanski & Geers, 2003; Hocevar-Boltezar, Boltezar and Zargi, 2008). This prediction has been shown to be further modulated by age at surgery; however, no definite conclusion is arrived at for its effect, leaving the question open to more investigation. The present study aims at investigating the effect of age at CI on the vowel space of CI users in comparison with NH listeners and extending the scope of previous studies to another cross-linguistic context by exploring the effect in Persian CI users.

### **Cochlear Implant, Vowel Production and Implantation Age**

It is well established that CI users are at an advantage compared to other hearing-impaired listeners, although falling short of demonstrating the same speech characteristics as NH listeners and that there is a gap between them caused by an initially restricted auditory feedback which can be bridged by rehabilitation and follow-up programs (de Souza, Bevilacqua, Brasolotto, & Coelho, 2012). Some of these differences relate to the production of vowels which are determinant segments in speech intelligibility. In most cases, vowel replacement gives rise to minimal pairs that would be undistinguishable and less differentiated from each other if they become more centralized or neutralized. As attempting to describe vowel from an articulatory perspective would not yield accurate objective results, acoustic characterization has been used to investigate vowel characteristics (Ladefoged & Johnson, 2010).

The studies on vowel space have demonstrated indefinite and contrasting results in comparative investigations of CI users and NH listeners. Horga and Liker (2006) and Liker, Mildner and Šindija (2007) have reported a significantly reduced vowel space for CI users. Verhoeven, Hide, De Maeyer, Gillis, and Gillis (2016) compared the acoustic characteristics of 12 Belgian Standard Dutch vowels articulated by the hearing impaired (CI and HA children) with NH children. According to their results, even after a long time of receiving implantation or wearing HA (5 years), the acoustic characteristics of hearing impaired children's vowels were meaningfully different from the NH children.

However, an increase in the vowel space has been mentioned in Hocevar-Boltezar et al. (2008) and Wang et al. (2017) which evidence the positive impact of CI. Other studies have even claimed an improvement to the point of similarity of vowel spaces after implantation. Uchanski and Geers (2003) compared the frequency of the second formant of two English vowels (/ɔ/ and /i/) in CI users and NH speakers and

found out that F2 of 87% of cases of /i/ and 88% of cases of /ɔ/ articulated by CI speakers were in the range of formant values for NH speakers. Baudonck, Van Lierde, Dhooge and Corthals (2011) did not also report any significant differences in the formant values of CI users compared with NH children.

To investigate the vowel space of Persian hearing-impaired children, Jafari et al. (2016) and Jafari, Yadegari and Jalaie (2016) in two successive studies found out an effect due to the length of device in CI users. Jafari et al. (2016) reported no improvement in the production of six Persian vowels by CI users who evidenced a centralized vowel space. Jafari, Yadegari and Jalaie (2016) explored the vowel production of HA, CI and NH speakers and claimed that one year after implantation, CI users performed better than HA speakers and the F1 and F2 values of their vowel productions demonstrated an expansion with a shift closer to vowel space in NH speakers.

The indeterminate direction of the results about CI children's voice and speech characteristics has been claimed by Poissant, Peters, and Robb (2006) to be "rule rather than the exception" due to methodological differences. The variety in the findings has been also attributed to the variability in how the factors have been defined and included in the design of the study such as the time span passed after cochlear implant use or children's age at the surgery.

One of the factors that have been taken into consideration to explore the impact of cochlear implant is age. There is a compelling need to investigate the best time for implantation because of the potential risks due to anesthetic complications (Young, 2002) or other additional medical or audiologic risks related to the patient physiology. Factors related to the type of the surgery and physical condition of the patient as skull size, scalp thickness and mastoid development should be attended to in making decision about the age of implantation (Waltzman & Ronald, 2005). On the other hand, implantation should be done at an age that would lead to an improvement in the linguistic abilities of the hearing-impaireds before they lose sensitivity to acquire fine phonetic features. Hearing screening in newborns has led to the early diagnosis of hearing impairment and subsequently early intervention and surgery are possible, but the appropriate time for implantation calls for more investigation.

It is well-established that implantation results in a different performance for children and adults. The majority of studies on CI postlingual adults demonstrate that CI surgery does not positively affects their language abilities compared to CI children (Neumeyer et al. 2010; Brian, et al. 2015). Hocevar-Boltezar et al. (2006) studied the articulation of three vowels (/i/, /a/ and /u/) in prelingually deaf children and postlingually deaf adults six months before and after implantation. Their study showed a significant difference in the frequency of formants before and after the surgery in children, but not in adults.

To find out when the sensitivity to auditory feedback is more beneficial for CI users, CI children at different ages have been studied. Tye-Murray, Spencer, and Woodworth (1995) carried out their study on three groups of CI children who had their surgery between (a) two to five (b) five to eight and (c) eight to fifteen years of age. The first group performed better in "phoneme accuracy" and "word intelligibility." A study on 73 CI children showed that the rate of growth in word recognition was faster in those who had undergone surgery before the three (Kirk et al., 2002). Children who received cochlear implant prosthesis at age two were reported to have had a better language development and speech perception than those who had the surgery at age three and four (Holt, Svirsky, Neuburger, & Miyamoto, 2004); and three and five (Svirsky, Teoh, & Neuburger 2004). Waltzman and Ronald (2005) had also found implant use beneficial before age 1 as it resulted in age-appropriate speech and listening performance, but caveats should be kept in mind regarding risky factors in the surgery process.

In a study on the interaction between age and length of device use, Connor, Craig, Raudenbush, Heavner, & Zwolan (2006) explored the language ability of four groups of CI children who had received their CI between 1 and 2.5, 2.6 and 3.5, 3.6 and 7, and 7.1 and 10 years of age. Results of their study demonstrated that children who had received their prosthesis before 2.5 years demonstrated a higher level of language ability. They concluded that early implantation is more beneficial than the longer length of device use at any given age.

Some studies have not reported any determinant role for age at implantation. Geers, Nicholas, Sedey (2003) carried a study on 181 CI children within the age range 8 to 9 years. The children had received their cochlear implant prosthesis before 5 years of age and their length of device use was between 4 and 7 years. The language skills of more than half of the children were the same as their normal hearing peers. The factors effective in CI children's language outcomes were "nonverbal intelligence", "family size", "socio-economic status" and "gender" rather than age at implantation. In another study, Geers (2004) has shown that early implantation between age two to four years did not guarantee their superiority in speech, language and reading skills over other CI children.

Investigations on the effect of age at cochlear implant surgery and vowel space have also yielded contrasting findings. Seifert et al. (2002) compared the articulation of Swedish-German /a/ by CI children in different time points after implantation with NH children. Their study revealed that F1/F2 ratio was normal in children who underwent surgery before four years of age, and it was more centralized in those who had surgery after four years. Zamani, Zarandy, Borghei, Rezai, and Moubedshahi (2016) have also shown that early implantation resulted in normal vowel production in Persian-speaking CI children. However, Neumeyer et al. (2010) did not find any age-related difference in vowel space between young and old German CI listeners.

Reviewing the different studies on CI speakers, no definite conclusions can be arrived at regarding the effect of early implantation on vowel space. However, it is certain that the accurate production of segments by CI users, specifically the closeness of their vowel space to NH listeners, ensures better perception of their speech by their interlocutors and might lead to their successful communication and better social life. It is also significant to find when the appropriate time is for implantation to minimize the potential risks of the surgery and maximize the language ability gain.

The main goal of this research is to find out whether Persian speaking CI children who have undergone implantation at a younger age (before three years) articulate six Persian vowels more accurately than those who received prosthesis later (after 3 years), and if their vowel space is closer to their normal hearing peers. To find an answer to the research question, the following null hypothesis would be addressed:

H01: There is no difference between the speech performance of CI users who received implantation before and after three.

Given the linguistic factors to be analyzed, it entails that three groups of CI<3, CI>3 and NH speakers produce F1 and F2 of vowels with similar values and show a similar vowel space surface area.

Although the safety and efficacy of early implantation is proven extensively in the current body of research, the present research contributes to the previous finding in Zamani et al. (2016) on Persian speaking CI children by widening the implantation age window from two to three years of age to see if the hearing-impaired children can still have a significant linguistic gain if they receive implantation a year later in their life. The findings will have a substantial economic consequence for low income families that cannot afford the CI surgery costs at an early age. The previous studies in Iran have been done on a large

body of CI users to the neglect of their socio-economic status and their language background, i.e. whether they are bilinguals or monolinguals, and if they are speakers of the same or various dialects. In spite of the small number of CI and NH speakers due to the place of its implementation- in a town other than the capital- and a limited number of cases satisfying the factors involved, the study shows an improvement by considering these two modulating factors. The present research takes for granted that by considering vowel space in CI users, we would have an index of language gain to find out the desirable cochlear implant age. While controlling for the intervening factors has led to a small sample that requires a cautious interpretation of the results, a near normal vowel space was found in CI<3 users. It can thus be concluded that even after a one year increase in the implantation age window, CI children can still have a linguistic gain comparable in some features to NH listeners.

## Method

### *Participants*

The participants were 10 CI children and 5 NH speakers. CI children (6 girls and 4 boys) were recruited from a private hearing rehabilitation center in Hamadan city, Iran. They had received auditory speech therapy regularly at the center both before and after cochlear implant surgery. Half of them had received their prosthesis before three years (CI<3) and half of them after three years (CI>3). All CI participants were diagnosed with severe congenital hearing loss at both ears and there was not any other disability and physical condition in them. The types of cochlear prosthesis used were Nucleus (seven cases) and Advance (three cases) in one ear and a mild hearing loss had been reported for all the CI children after surgery. The average chronological age of the subjects in CI<3 group was 7.9 years (ranging between 5.10 to 9.6 years) and in the CI>3 group was 8.5 years (ranging between 7.8 to 9.6 years). All of the children were living in Persian-speaking families with a middle socio-economic status in Hamadan province. Table 1 summarizes the demographic information related to the CI participants. NH participants (2 girls and three boys) were matched for age, language background and socio-economic status, and did not have any speech or hearing disability or any physical and/or developmental problem. Their average age was 7.5 years.

Table 1. Demographic information of CI participants.

Participants	Chronological Age (year)	CI Age (year)	Length of Device Use (year)	CI Type
CI<3-1	9.6	1.6	8	Nucleus
CI<3-2	7.4	2	5.4	Nucleus
CI<3-3	7.3	2	5.3	Nucleus
CI<3-4	7	2.2	4.10	Nucleus
CI<3-5	5.10	2	3.10	Advance
CI>3-1	9.6	3.6	6	Nucleus
CI>3-2	8.6	4	4.6	Nucleus
CI>3-3	8.6	4	4.6	Nucleus
CI>3-4	8.1	3.6	4.7	Advance
CI>3-5	7.8	4	3.8	Advance

As the age at the time of cochlear implant is the main variable of this study and it has been proved to be positively associated with duration of device use, the latter variable was also included. The length of device use was decided upon to be at least three years because in studies where the time span after the surgery was less than one year, no statistically significant improvement in the language abilities of CI children has been reported (Jafari et al. 2016) and differential effects have only emerged after a longer cochlear implant usage due to more accommodation with the device and receiving enough auditory feedback (Seifert et al. 2002). The mean length of device use was 5.5 years for CI<3 group and 4.7 years for CI>3 group. A two sample t-test showed that this difference was not significantly different ( $t(8)=.49, p > .05$ ), probably due to the small number of participants.

#### *Data collection*

All of the six Persian vowels (/u/, /o/, /a/, /i/, /e/, /æ/) were presented and recorded in the smallest Persian syllable (CV). To minimize the effect of a single consonant on the vowels, all of the Persian plosive sounds were chosen as the onset consonants (/p/, /b/, /t/, /d/, /k/, /g/, /q/, /ʔ/). Participants were instructed to repeat every syllable after a speech therapist. The same speech therapist was present in all the recordings. Every one of the children articulated the set of syllables two times, and the total number of stimuli collected from two groups of CI users and a group of NH children were 1440 items (15 speakers \* 6 (vowels) \* 8 (plosives) \* 2 (repetitions) =1440) and each speaker produced 96 items.

During the process of repeating the syllables, they could have rested whenever they needed. Recording the data was done by the interchangeable microphone of Zoom H6 recorder which was fixed in 15 centimeters from children's mouth. Recording CI children's sound was carried out in an acoustic room in speech therapy department of Besat Hospital in Hamadan and NH children's sound was recorded in a quiet room in their school in Hamadan. The parents of all children (CI and NH) signed the informed consent before recording the sounds.

#### *Acoustic analysis*

For perceptual assessment, a linguist listened to the all 1440 recordings and approved them. Using Praat software (Boersma & Weenink, 2015) version 6.0.08, the acoustic analysis was conducted on the recordings through visual inspection. Between 1.8 and 3 milliseconds from the middle of the vowels were selected to determine the frequency of the first and the second formants of the vowels. We analyzed the middle of vowels because of its more consistency in production (Jafari et al., 2016) and its minimal influence from the syllable's onset and coda - here the Persian plosives and silence (Verhoeven et al., 2016).

#### *Vowel space surface area*

For the vowel space of the three groups, the mean F1 and F2 of the vowels were depicted in a graph, where X axis represented F2 of each vowel and Y axis represented F1 of the vowels. The representative points for vowels were connected to each other to illustrate the vowel space area for each group. Each point in the graph demonstrated the relative place of the vowels produced by each group in the vowel space.

In addition to the above-mentioned graph, we borrowed Quadrilateral VSA metric formula from Jafari et al. study (2016) to compare the vowel space area of the studied groups. QVSA formula uses the mean F1 and F2 of four vowels (/i/, /a/, /u/, /æ/) measured in hertz to arrive at a quadrilateral representation of the vowel space:

$$\text{Area} = 0.5 * \left\{ \left( \frac{i}{F2} * \frac{\text{æ}}{F1} + \dots + \frac{F2}{a} * \frac{F1}{a} + \frac{a}{F2} * \frac{u}{F1} + \frac{u}{F2} * \frac{i}{F1} \right) - \left( \frac{i}{F1} * \frac{\text{æ}}{F2} + \frac{\text{æ}}{F1} * \frac{a}{F2} + \frac{a}{F1} * \frac{u}{F2} + \frac{u}{F1} * \frac{i}{F2} \right) \right\}$$



*Statistical Analysis*

By using descriptive statistics, mean and standard deviations of the maximum and minimum F1 and F2 of six Persian vowels were reported. The normality test revealed that the data were not distributed normally, presumably due to the small number of the participants and Kruskal-Wallis test was used. In cases of significant differences, Mann-Whitney test was used to compare the differences between each of the two groups. In all cases, significance level was set at 5%.

**Results**

In this study, 1440 vowel realizations produced by CI<3, CI>3 and NH children were analyzed acoustically. The analysis focused on the spectral characteristics (F1 and F2) of Persian vowels and the surface area of vowel space in the three groups.

*Formant Frequencies of vowels*

The comparison of F1 and F2 of six Persian vowels produced by CI and NH children is reported in Table 2. As can be read from the table, statistically significant differences were observed among the three groups in F1 and F2 of all vowels, except for both formants of vowel /æ/ and F2 of Vowels /i/ and /e/.

Table2. Comparison of F1 and F2 of Persian vowels among CI<3, CI>3 and NH children. Significant p-values are underlined.

Parameter(Hz)	CI <3		CI >3		NH		p-value
	M	SD	M	SD	M	SD	
/ i / F1	441.4	76.7	420.7	176	338.9	49.8	<u>0.0001</u>
/i / F2	2933.6	339.3	2997.9	264.7	2984.1	217.6	0.493
/e/ F1	691.4	98.3	614.4	91	567.5	59.8	<u>0.0001</u>
/e/ F2	2496.7	290.1	2534.1	304.3	2459.9	233.9	0.308
/ æ /F1	1117.3	176.7	1046.2	203.8	1086.6	136.4	0.287
/ æ /F2	2003.8	289.3	1967.2	183	1957.8	189.5	0.57
/u/F1	419.9	67.1	419.1	95.2	380.2	57	<u>0.004</u>
/u/F2	1048.9	162.2	1139.7	185.2	1086.4	313.4	<u>0.004</u>
/o/F1	607.9	80.6	624.6	119.4	527.2	41.7	<u>0.0001</u>
/o/F2	1345.9	288	1503.8	335.1	1131.4	152.1	<u>0.0001</u>
/a/F1	913.1	114	855.8	156	800.3	90.6	<u>0.0001</u>
/a/F2	1469.1	144.8	1493.9	200.3	1421.6	201.4	<u>0.003</u>

The maximum F1 in the three groups belongs to /æ/ and the minimum F1 belongs to /u/ in the CI groups and to /i/ in the NH group. The maximum and minimum F2 in the groups belongs to /i/ and /u/ respectively.

To further find out between which sample pairs the differences exist, Mann-Whitney U test was run on the eight cases that showed significant differences (Table 3). The CI<3 and NH groups were significantly different from each other in terms of F1 of the vowels /i/, /e/ and /u/, and F1 and F2 of the vowels /o/

and /a/. The comparison between CI>3 and NH groups demonstrated significant differences in all eight cases (F1 of /i/ and /e/ and F1 and F2 of /u/, /o/ and /a/). CI<3 and CI>3 groups were statistically different from each other in F1 of /i/ and /e/ and F2 of /u/, /o/.

Table 3. Pairwise comparison of CI<3, CI>3 and NH children in significant differences. The significant level is set at <.05. Significant p-values are underlined.

Parameter	CI<3-NH	CI>3-NH	CI<3-CI>3
/i/F1	<u>&lt;0.0001</u>	<u>&lt;0.0001</u>	<u>&lt;0.0001</u>
/e/F1	<u>&lt;0.0001</u>	<u>0.001</u>	<u>&lt;0.0001</u>
/u/F1	<u>0.001</u>	<u>0.021</u>	0.328
/u/F2	0.6	<u>0.004</u>	<u>0.006</u>
/o/F1	<u>&lt;0.0001</u>	<u>&lt;0.0001</u>	0.716
/o/F2	<u>&lt;0.0001</u>	<u>&lt;0.0001</u>	<u>0.003</u>
/a/F1	<u>&lt;0.0001</u>	<u>&lt;0.0001</u>	<u>0.03</u>
/a/F2	<u>0.002</u>	<u>0.004</u>	0.547

Vowel space

Based on the F1/F2 ratio of the Persian vowels, vowel spaces for the three groups were depicted in Figure 1. According to this figure, vowel spaces of CI children (both CI<3 and CI>3) are smaller than NH children both horizontally (the distance between front and back vowels) and vertically (the distance between high and low vowels). Comparing the vowel spaces of CI children with each other revealed that the vowel space in the CI>3 group is more compressed than the CI<3 group.

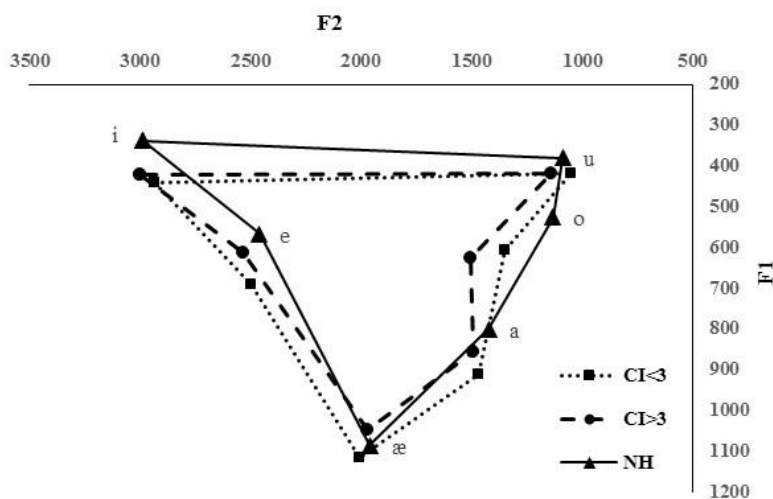

Fig. 1. Vowel space for CI&lt;3, CI&gt;3, NH children.

In addition to the graphic representation of vowel spaces of three groups, using QVSA formula vowel space planar area was calculated for the groups. The F1-F2 planar area was 729880 Hz<sup>2</sup> for the CI<3 group and 695220 Hz<sup>2</sup> and 760770 Hz<sup>2</sup> for the CI>3 and NH groups, respectively. No significant difference between CI<3 and NH group was observed ( $P=0.177$ ), while the comparison between the CI>3 and NH groups revealed a significant difference ( $P=0.03$ ). The difference between F1-F2 planar areas in CI groups was not significant ( $p=0.316$ ).

## Discussion

The purpose of this study was to assess the effect of age at the time of cochlear surgery on vowel space of Persian speaking CI children. The participants in the study were chosen through convenience sampling to have two case groups of CI children, those who have received implantation before three and those who have received it after three and one age-matched control group of NH children. They repeated 1440 CV syllables after a speech therapist. The vowel realizations were analyzed acoustically to investigate F1 and F2 values of vowels and calculate the vowel space area. The findings of the study revealed significant differences in formant frequencies and vowel space area among these groups and rejected the null hypothesis that there is no difference between the speech performance of CI users who received implantation before and after three.

### *F1 and F2 of the vowels*

#### *F1 of the vowels*

Comparing the CI and NH children regarding the F1 of Persian vowels, we realized that the former group had produced the vowels /i/, /e/, /u/, /o/ and /a/ with a significantly higher frequency than the latter group. Since F1 is related to the tongue's height during the articulation of a vowel and higher F1 indicates open vowels while the lower F1 represents the close vowels, it is concluded that in our study, CI children had articulated the mentioned vowels more open than their NH peers.

This finding is in accordance with Jafari, Yadegari and Jalaie (2016) who have reported higher F1 of all six Persian vowels in CI children's productions; however the difference was significant just in one case (/i/). The exaggerated training method aiming at providing the CI children with proprioceptive feedback has been claimed to be responsible for their shifted production in the case of /i/. As the training method that the CI children in our study had received was Auditory Verbal Therapy and the trainers were observed to articulate the vowels exaggeratedly to give visual cues for the position of vowels in the mouth, the vowels by CI children had been formed with more open mouths than normal vowels. The shifted production was not limited to /i/ as in Jafari, Yadegari and Jalaie (2016) and encompassed all Persian vowels, except for /æ/.

Comparing F1 of two low Persian vowels (/a/ and /æ/) provides evidence for this claim. The comparison shows that although both /æ/ and /a/ are open vowels, F1 of /æ/ is not significantly different between CI and NH children, while the difference is significant for /a/. The reason seems to be the fact that /æ/ is both the most open and a front Persian vowel and its place of articulation is visible for CI children, hence no need to be trained exaggeratedly. While /a/, another open vowel, which is not completely visible for CI children because of its place of articulation (back), is trained with more open mouth to give CI children better visual feedback of its place.

Some studies have reported findings that are in contrast with our findings regarding F1. Liker et al. (2007) have reported a closer articulation for vowel /a/ in CI children compared to their NH peers which they

have attributed to the "decreased jaw movement" of the former group. A similar finding is reported in Verhoeven et al. (2016). CI children produced the F1 of the five Belgian Standard Dutch vowels under study lower than NH children. The visibility of tongue height and mouth openness has been mentioned as the cause of similar F1 in CIs and NHs in these two studies. The same reason is responsible for the more open production of Persian vowels by CI children in this study, but with a different outcome in making the F1 of these vowels higher. The reason behind the higher F1 of CI children lies in the accessible visual cue of tongue height provided by trainers. Exaggerated training brings about both the advantage of recognizing the place of articulation of vowels, and the disadvantage of production of more than normal open vowels.

Comparing F1 of Persian vowels produced by children in the CI<3 and The CI>3 groups reveals significant differences in three vowels /i/, /e/ and /a/. CI<3 children articulated these three vowels more open or lower than the latter group. As explained before, it is possibly due to the exaggerated training, but CI<3 children might have been more influenced by this training method because of their exposure at an earlier age.

#### *F2 of the vowels*

Regarding F2 of Persian vowels, three back vowels (/u/, /o/ and /a/) were significantly higher in CI children compared to their age-matched NH children. Higher F2 ends in fronting vowels and lower F2 results from producing the vowels more back. CI children had thus been found to produce three Persian back vowels more front than their normal position.

This finding which might be explained by recourse to lack of visual cues for the place of articulation in back vowels, is in agreement with Neumeier et al. (2010) who has reported a significant difference in F2 of 5 German vowels between young and old CIs compared to young and old NHs. Jafari, Yadegari and Jalaie (2016) and Verhoeven et al. (2016) have also observed a tendency toward the neutralization of vowels articulated by CIs, i.e. back vowels are produced as more front with higher than normal F2 and front vowels as more back with lower than normal F2. We observed this centralization of vowels in back vowels, but not in front vowels.

Time span after cochlear implant appears to have positively affected the F2 values of front vowels. Length of device use, which has been at least three years in the current study and 1 year in Jafari, Yadegari and Jalaie (2016) can be said to be the source of difference between these two studies as the latter showed vowel neutralization. Time span after the surgery might have benefited CI children in our study more to produce front vowels with normal F2 due to both their adjustment with the device and more exposure to auditory feedback. However, as the length of device use has been longer (more than five years) in Verhoeven et al. (2016) compared to our study, length of device use might not completely justify the difference in F2 of front vowels between them. We may thus relate it to different training methods used for CI children in these two studies. The exaggerated training with higher degrees of mouth opening might have helped CI children in the present study to correctly find the place of articulation of front vowels.

Comparing F2 of Persian vowels produced by the two CI groups showed that in three back vowels (/u/, /o/ and /a/), it was found higher in the CI>3 group and reached a significant difference in vowels /u/ and /o/. This difference might be attributed to implantation age. Children who had received the implant at a younger age, have had access to auditory feedback earlier in life when they are more sensitive to fine phonetic features and it has accordingly benefited them with an improvement in the production of F2 in back vowels. The positive effect of younger age at the time of the surgery on the F2 of back vowels has

also been observed in Seifert et al. (2002). They found better acoustic control over speech in children who have received the prosthesis before four years compared to those who have received it after four years.

#### *Vowel space*

The comparison of vowel spaces (Figure 1) in this study shows that CI children's vowel space (both CI<3 and CI>3) is more compressed than in NH children both horizontally and vertically. This finding is completely in contrast with the results of Baudonck et al. (2011) that does not reveal any significant difference between vowel spaces of CI and NH children.

The horizontal compression of CI children's vowel space in our study is in compliance with the findings of other studies (Neumeyer et al. 2010, Jafari et al. 2016, Verhoeven et al. 2016). It results from lack of visual feedback for the place of articulation of vowels leading to more central production of vowels by CIs, even after three years of device use.

Comparing the horizontal line of vowel spaces in the two groups of CI children revealed its shortness in the CI>3 group. The short distance between front and back vowels in the CI>3 group illustrates the inclination in this group to produce back vowels (especially /u/ and /o/) as more front in contrast to CI<3 children. This finding can be justified with the age at the time of CI surgery. Younger age at the time of surgery leads to more distinctions between vowels and a normal distance between the back and front vowels articulated by CI children, while undergoing the surgery at an older age results in a compressed vowel space in horizontal line.

The next feature of vowel space observed in CI children, namely its vertical shortness compared to NH children, is not supported in the other studies. The formation of more than normal open vowels except for /æ/ due to the increased F1 of the vowels and the subsequently vertical shortness of vowel space in CI children might have their origin in the exaggerated training of vowel formation with open mouth. Hence, it seems to be a local rather than a general problem of CI children.

Besides the vowel space surface area, the positive effect of early cochlear implantation on vowel space of CI children is revealed by comparing the groups' vowel space planar area. The difference in vowel space planar area between the CI>3 and NH groups is statistically significant. It is in agreement with the results of Jafari, Yadegari and Jalaie (2016) and Liker et al. (2007) studies that have demonstrated smaller vowel space of CI children compared to NH participants because of the increased F2 value of vowels. Comparing the CI<3 and NH children demonstrated no significant difference in spite of smaller vowel space planar area in CI children. Horga and Liker (2006) and Uchanski and Geers (2003) have reported the same result. We attribute the differences in the vowel space planar area of CI groups to their age at the time of implantation. Because CI<3 children have used the device at a younger age and they have had the advantage of exposure to aural feedback earlier in their lives than the CI>3 group, they are more successful in recognizing the place of articulation of vowels and differentiating between them.

The findings should be interpreted with caution because of the limited sample. However, the study design shows an improvement on previous studies by widening the time span after cochlear implant surgery to investigate the differences that might emerge after longer period of device use. It has also controlled the groups for language and socio-economic background to arrive at a comparable homogenous sample. In this study, the participants were required to imitate the isolated production of syllables which rarely occur in everyday communication. These vowels should be addressed in connected speech and CI children should be required to be involved in a communicative task so as to investigate the efficacy of CI in successful communication.

In spite of the shortcomings, the above findings provided evidence for the differences among the three groups of CI<3, CI>3 and NH children. The difference between the F1 values of all vowels except for /æ/ between both CI groups can be taken as resulting from their implantation age. The same difference between CI and NH children on the other hand might be attributable both to the gap caused by auditory feedback deprivation that persists even after at least three years of implantation and the exaggerated open-mouthed training method. The increased F2 values of back vowels in CI children could be traced to the lack of visual cues for back vowels, specially as the the language learning experiences of CI children suggests the undeniable influence of a training method that relies heavily on the exaggerated segmental productions to provide visual cues. Although the compressed but shifted vowel space area as a representation of F1/F2 ratio in CI children compared to the NH group demonstrates the persistent gap between them due to restricted auditory feedback, the difference between both CI groups points at the positive effect of early implantation.

### Conclusion

This study addressed the effect of age at cochlear implant surgery on the vowel space of Persian speaking CI children. To this end, we assessed the acoustic characteristics of all six Persian vowels produced by children who received the implant before and after three years of age in comparison to a normal hearing control group. Although the vowel space of all CI children was more compressed than NH children- even after 3 years of device use, the difference was significant between CI>3 and NH children. A shift in both height and articulatory place of vowels was observed. CI children produced all vowels except for /æ/ as more open and back vowels as more front, with the latter being more observable in CI>3 children emphasizing the beneficial effect of early implantation on the horizontal line of vowel space. The shift to more open vowels could be traced back to the training method. We predict that if trainers articulate the vowels without exaggeration, CI children's vowel space would be the same as NH children in the vertical line. However, more research is required on CI children trained by different speech trainers and using different methods to calim with certainty that this shift is a local issue, rather than a problem shared by all Persian speaking CI children. Aside from F1 of the vowels or the vowel space height in the two CI groups, the horizontal line of their vowel space confirms our hypothesis that early cochlear implant has positive effects on recognizing the vowel articulatory position, and causes near normal vowel space.

### References

- Baudonck, N., D'haeseleer, E., Dhooge, I., Van Lierde, K. (2011). Objective vocal quality in children using cochlear implants: a multiparameter approach. *Journal of Voice*, 25(6), 683-691.
- Baudonck, N., Van Lierde, K., Dhooge, I., & Corthals, P. (2011). A comparison of vowel productions in prelingually deaf children using cochlear implants, severe hearing-impaired children using conventional hearing aids and normal-hearing children. *Folia Phoniatica et Logopaedica*, 63(3), 154-160.
- Boersma, P. & Weenink, D. (2015). Praat: Doing phonetics by computer (Version 6.0.08). Computer program. <http://www.praat.org/>.
- Brian, S., Gandolfi, M., Lai, E., Reilly, E., Singer, L., Kim, A.H. (2015). The Impact of Age on Cochlear Implant Performance. *International Journal of Otolaryngology and Head & Neck Surgery*, 4, 329-337.
- Connor, C.M., Craig, H.K., Raudenbush, S.W., Heavner, K., Zwolan, T.A. (2006). The age at which young deaf children receive cochlear implants and their vocabulary and speech-production growth: is there an added value for early implantation? *Ear and hearing*, 27(6), 628-44.

- de Souza, L. B. R., Bevilacqua, M. C., Brasolotto, A. G., & Coelho, A. C. (2012). Cochlear implanted children present vocal parameters within normal standards. *International journal of pediatric otorhinolaryngology*, 76(8), 1180-1183.
- Ertmer, D. J., & Goffman, L. A. (2011). Speech Production Accuracy and Variability in Young Cochlear Implant Recipients: Comparisons with Typically Developing Age-peers. *Journal of Speech, Language, and Hearing Research*, 54(1), 177-189. [http://doi.org/10.1044/1092-4388\(2010/09-0165\)](http://doi.org/10.1044/1092-4388(2010/09-0165)).
- Geers, A. (2004). Speech, language, and reading skills after early cochlear implantation. *Arch Otolaryngology Head Neck Surg*, 130(5), 634-8.
- Geers, A., Nicholas, J., Sedey, A. (2003). Language skills of children with early cochlear implantation. *Ear and Hearing*, 24(1), 46S-58S.
- Geers, A., Tobey, E., Moog, J., Brenner, C. (2008). Long-term outcomes of cochlear implantation in the preschool years: from elementary grades to high school. *International Journal of Audiology*, 47(2), S21-S30.
- Harnsberger, J. D., Svirsky, M. A., Kaiser, A. R., Pisoni, D. B., Wright, R., & Meyer, T. A. (2001). Perceptual "vowel spaces" of cochlear implant users: Implications for the study of auditory adaptation to spectral shift. *The Journal of the Acoustical Society of America*, 109(5 Pt 1), 2135-2145.
- Hocevar-Boltezar, I., Radsel, Z., Vatovec, J., Geczy, B., Cernelc, S., Gros, A., et al. (2006). Change of phonation control after cochlear implantation. *Otology & Neurotology*, 27(4), 499-503.
- Holt, R. F., Svirsky, M. A., Neuburger, H., & Miyamoto, R. T. (2004, November). Age at implantation and communicative outcome in pediatric cochlear implant users: Is younger always better?. In *International congress series* (Vol. 1273, pp. 368-371). Elsevier.
- Horga, D., Liker, M. (2006) Voice and pronunciation of cochlear implant speakers. *Clinical Linguistics & Phonetics*, 20(2-3), 211-7.
- Jafari, N., Drinnan, M., Mohamadi, R., Yadegari, F., Nourbakhsh, M., Torabinezhad, F. (2016). A comparison of Persian vowel production in hearing-impaired children using a cochlear implant and normal-hearing children. *Journal of Voice*, 30(3), 340-4.
- Jafari, N., Yadegari, F., Jalaie, S. (2016). Acoustic analysis of Persian vowels in cochlear implant users: a comparison with hearing-impaired children using hearing aid and normal-hearing children. *Journal of Voice*. In press.
- Kirk, K., Miyamoto, R., Ying, E., Lento, C., O'Neill, T., Fears, F. (2002). Effects of age at implantation in young children. *Annals of Otology, Rinology, and Laryngology*, 111, 69-73.
- Ladefoged, P., & Johnson, K. (2010). *A Course in Phonetics*. Boston: Wadsworth/Cengage Learning Inc.
- Ladefoged, P., & Disner, SF. (2012). *Vowels and consonants*. (3rd ed.). John Wiley & Sons.
- Liker, M., Mildner, V., Šindija, B. (2007). Acoustic analysis of the speech of children with cochlear implants: A longitudinal study. *Clinical linguistics & phonetics*, 21(1), 1-11.
- McConkey, A., Svirsky, M., Iler Kirk, K. (1997). Children with Implants Can Speak, But Can They Communicate? *Otolaryngology -- Head and Neck Surgery*, 117(3), 155-160.
- Moog, J.S. (2002). Changing expectations for children with cochlear implants. *Annals of Otology, Rhinology, & Laryngology*, 111, 138-142.
- Neumeyer, V., Harrington, J., Draxler, C. (2010). An acoustic analysis of the vowel space in young and old cochlear-implant speakers. *Clinical linguistics & phonetics*, 24(9), 734-41.
- Paatsch, L., Blamey, P., Sarant, J., Bow, C. (2006). The effects of speech production and vocabulary training on different components of spoken language performance. *Journal of Deaf Studies and Deaf Education*, 11(1), 39-55.
- Poissant, S.F., Peters, K.A., Robb, M.P. (2006). Acoustic and perceptual appraisal of speech production in pediatric cochlear implant users. *International journal of pediatric otorhinolaryngology*, 70(7), 1195-203.
- Seifert, E., Oswald, M., Bruns, U., Vischer, M., Kompis, M., Haeusler, R. (2002). Changes of voice and articulation in children with cochlear implants. *International Journal of Pediatric Otorhinolaryngology*, 66(2), 115-23.

- Svirsky, M.V., Teoh, S., Neuburger, H. (2004). Development of language and speech perception in congenitally, profoundly deaf children as a function of age at cochlear implantation. *Audiology & Neuro-Otology*, 9, 224-233.
- Tobey EA, Geers AE, Brenner CB, Altuna D, Gabbert G. Factors associated with development of speech production skills in children implanted by age five. *Ear and Hearing*. 2003;24:36S-45S.
- Tye-Murray, N., Spencer, L., Woodworth, G. (1995). Acquisition of speech by children who have prolonged cochlear implant experience. *Journal of Speech and Hearing Research*, 38, 327-337.
- Uchanski, R.M., Geers, A.E. (2003). Acoustic characteristics of the speech of young cochlear implant users: a comparison with normal-hearing age-mates. *Ear and hearing*, 24(1), 90S-105S.
- Verhoeven, J., Hide, O., De Maeyer, S., Gillis, S., Gillis, S. (2016). Hearing impairment and vowel production. A comparison between normally hearing, hearing-aided and cochlear implanted Dutch children. *Journal of communication disorders*, 59, 24-39.
- Waltzman, SB., Roland, J.T.Jr. (2005). Cochlear implantation in children younger than 12 months. *Pediatrics*, 116, 487-493 .
- Wang, Y., Liang, F., Yang, J., Zhang, X., Liu, J., & Zheng, Y. (2017). The Acoustic Characteristics of the Voice in Cochlear-Implanted Children: A Longitudinal Study. *Journal of Voice*.
- Young, N. (2002). Infant cochlear implantation and anesthetic risk. *Annals of Otology, Rinology, and Laryngology*, 111, 49- 51.
- Zamani, P., Zarandy, M. M., Borghei, P., Rezai, H., & Moubedshahi, F. (2016). The role of age implantation on formants frequency changing in early and late cochlear implanted children: a study based on perceptual and acoustical assessments. *Auditory and Vestibular Research*, 25(1), 24-31.



## Valence effects on phonological processing in normal Persian speaking children: A study by ERP

Sousan Salehi<sup>1</sup>, Ahmad Reza Khatoonabadi<sup>1\*</sup>, Mahmoud Reza Ashrafi<sup>2</sup>, Ghasem Mohammadkhani<sup>3</sup>, Saman Maroufizadeh<sup>4</sup>

<sup>1</sup> Department of Speech Therapy, School of Rehabilitation, Tehran University of Medical Sciences, Tehran, Iran

<sup>2</sup> Department of Child Neurology, Children's Medical Center, Tehran University of Medical Sciences, Tehran, Iran

<sup>3</sup> Department of Audiology, School of Rehabilitation, Tehran University of Medical Sciences, Tehran, Iran

<sup>4</sup> Department of Epidemiology and Reproductive Health, Reproductive Epidemiology Research Center, Royan Institute for Reproductive Biomedicine, ACECR, Tehran, Iran

### Abstract:

**Objective:** Emotional content and language processing has mutual relationship. But there is limited evidence in emotional production. Verbal emotion has two aspect including arousal and valence. The aim of the present study is investigation of effect of valence on phonological processing in Persian speaking children by ERP.

**Material and methods:** One hundred and twenty emotional words in three categories including positive (high valence or pleasant), negative (low valence or unpleasant) and neutral was given to 10 normal Persian speaking children to read aloud. Concurrently, Event Related Potentials were recorded by 64 electrodes. Phonological processing was supposed to be 100-400ms before articulation onset. Behavioral and electrophysiological results were analyzed in this time range.

**Results:** Positive words have more accuracy and smaller reaction time compare to negative words. These differences were statistically significant. Positive words extracted larger amplitude in frontal, temporal and posterior regions. Neutral word have larger amplitude in central regions. Topography illustrated diffuse activity in emotional words. There were significant differences between negative, positive and neutral words in prefrontal and right posterior regions.

**Conclusion:** Emotion increases brain activity in some regions. It lead in faster processing. Emotional content decreases amplitude and helps to phonological processing in limited regions.

**Key words:** Emotion, Valence, Phonological Processing, ERP, Normal Persian Speaking Children

### Introduction:

There is bilateral well-documented relationship between language processing and emotion. There is two main ways to produce emotion in language, verbal expression of emotion or emotional content and nonverbal or prosodic way [1]. It has been shown that emotional content has a key role in language processing even in single word processing[2]. Emotion in language has two dimensions, including: arousal and valence (pleasant). which are based on evaluative reactions[3]. Valence implies to pleasant or non-pleasant words and arousal implies to agitation and calm of the word[4].

Decoding and encoding of emotional information are done quickly, then electrophysiological assessments can be very useful for the investigation [5]. Event Related Potentials (ERP) is an electrophysiological neuroimaging method which is recorded from scalp with millisecond time resolution, thereby help to unfold various levels of language processing[6]. ERP was utilized in emotional content word processing investigations, the most related results will be explained in the following.

Generally, it is shown that valence improve the function of word recognition[7]. It has been demonstrated that valence has effect on early response with dipolar fronto-occipital topography, high valence words generated higher amplitude than low valence words. The amplitude of the late positive complex (LPC)

was different in neutral and emotional content words. Emotional word also have higher amplitude in left parietal region. Conversely in central region, neutral words have higher amplitude in reading task in Polish speaking adults[8]. Similarly in another investigation, the results showed positive (high valence) words were processed faster than negative (low valence) words as well as there was a decrease of N400 (300-410 ms) amplitude in positive words. Additionally, LPC amplitude (450-750 ms) was increased in positive words in lexical decision task [9]. Generally, it is illustrated that emotional words has enhancement in brain responses. There is electrophysiological responses for pleasant and unpleasant words generated from occipito - temporal regions in 200-300 ms after word onset in silent reading tasks. Besides, arousal is more effective than valence in other tasks. Emotional words also recalled faster than neutral words[10]. Then, ERP modulations are influenced by tasks too. Kissler and et al reported that EPN amplitude for emotional content words was increased in silent reading task in arousing words and it is influenced by word frequency. But LPC was depended on type of task, not emotional content[10]. Other ERP components which are reportedly related to emotional content are including P1-N1 and P2-N2, which are appeared in time window in 100-200 ms and 200-260 ms, respectively [11].

Previously, studies showed that emotional content effect on ERP recording in word comprehension, but little is known about emotional word production. Hinsonja and et al conducted a study for emotional words production investigation with emotional and neutral picture naming task, they suggested that neutral picture naming had shorter reaction time. There was increased amplitude in positive component in 400 millisecond for emotional content picture naming. They interpreted that it represented an interruption in phonological processing because of affective content[12].

Notably, there are two ERP analysis methods, stimulus-locked and response-locked[13]. All mentioned studies use stimulus locked method, whereas in the present study we will use response locked method and visual inspection[13].

On the other hand, phonological processing as a part of language processing will be considered a level before articulation, based on Levelt's model of speech production[14]. Therefore, 100-400 millisecond before voice onset supposed to be phonological processing level of language processing in ERP analysis[15].

Additionally, there are a variety of tasks which are contained phonological processing such as aloud reading[16], as well as processing of emotional content words is questionable [17]. Then, phonological processing will be assessed by aloud reading task in the present study.

The present study is aimed to investigate influence of valence (pleasant and unpleasant) on phonological processing in normal Persian speaking children.

#### **Method:**

##### **Participants:**

Ten normal children (7 boys), aged 7 - 10 years (Mean=8.7; S.D. = 0.12) had been taken part in this study. They were all monolingual native Persian speaking children with corrected to normal or normal vision. They have all normal speech - language - psycho - motor development, according to parent's reporting and medical history. All were right handed according to Edinburg Handedness Inventory [18]. The study was approved by the ethics committee of Tehran University of Medical Sciences (TUMS). All parents signed written informed consent form.

##### **Stimulus materials:**

There is an emotional Farsi words list that is evaluated based on arousal and valence (pleasant) score[19]. A first set of 180 emotional Persian words was selected from it according their scores in comprehensibility on children. Then these words were matched in frequency and length of words, finally 120 emotional words were prepared for the test. We categorized the words according their valence, then the list is including, 40 neutral words (their arousal and valence scores are  $4\pm S.D.$ ), 40 positive words (their valence score is more than  $4\pm S.D.$  with any score in arousal) and 40 negative words (their valence score is less than  $4\pm S.D.$  with any score in arousal), which are matched in frequency and word length ( $p$ -value  $> 0/05$ ).

**Procedure:**

Children and their parents were familiarized with laboratory setting and the procedure of EEG recording. Then parents were asked to fill personal information forms. Children were seated on the chair in an acoustic room facing a PC monitor at the distance 40 cm and an ERP cap containing 64 electrodes was positioned on their head so that the Fpz was at 1/10 Nasion to Inion, it was metered by a measure tape for each participant. The size of cap was selected based on their head circumference. Microphone for verbal response recording was at the distance of 10 cm from the mouth. Then they were instructed to read the words aloud as soon as these appear on monitor. Before the main experiment, the training was administered by 10 words. When the subjects get ready, then the main trial would be begun with 120 emotional words. All words with any emotional content were presented in pseudorandom sequence. Each subject was given 120 words, 40 neutral, 40 positive and 40 negative words, between words a plus sign (+) was presented as fixation for 1000 ms. The stimuli were showed in black font (B Titr, size 64) on a grey background during 2000 ms in the center of the screen.

**EEG recording:**

EEG was recorded from 64 channels attached to a cap based on 10-10 international system of electrode placement. All electrodes were re-referenced to the average of left and right mastoids. The recording data was conducted with a sample rate of 256 Hz using by EB-Neuro system and Galileo Net software (Italy). The data bandwidth was 0.1 Hz to 40 Hz. Responses between 200-2000 ms after stimuli presentation would be calculated as accurate response.

**EEG analysis:**

The EEGLAB software was utilized for ERP visualization and analysis. Data was preprocessed with ASR and PREP pipeline[20, 21]. To determine time windows for ERP and region of interest repeated measure was conducted by EEGLAB.

**Statistical analysis**

In this study, continuous variables were expressed as mean (standard deviation). Repeated-measures ANOVA, followed by the Bonferroni test, was used to comparison between word categories. Statistical analysis was carried out with IBM SPSS Statistics for Windows, Version 22.0 (IBM Corp., Armonk, NY, USA). All statistical tests were two-sided and a  $P < 0.05$  was considered statistically significant.

**Results:**

**Behavioral results:** accuracy and Reaction Time (RT) was calculated. RT also was obtained from accurate responses.

Accuracy: there was significant differences between accurate responses in positive, negative and neutral words ( $F(2, 18) = 9.59; P = 0.001$ ). Benferroni test showed that accurate response in positive words was significantly more than negative words ( $P < 0.001$ ). As seen in Figure 1, the mean of accurate responses in positive emotional content words was more than neutral words, but this difference was not statistically significant ( $P = 0.143$ ). Also, the difference between neutral and negative words was not significant ( $P = 0.504$ ).

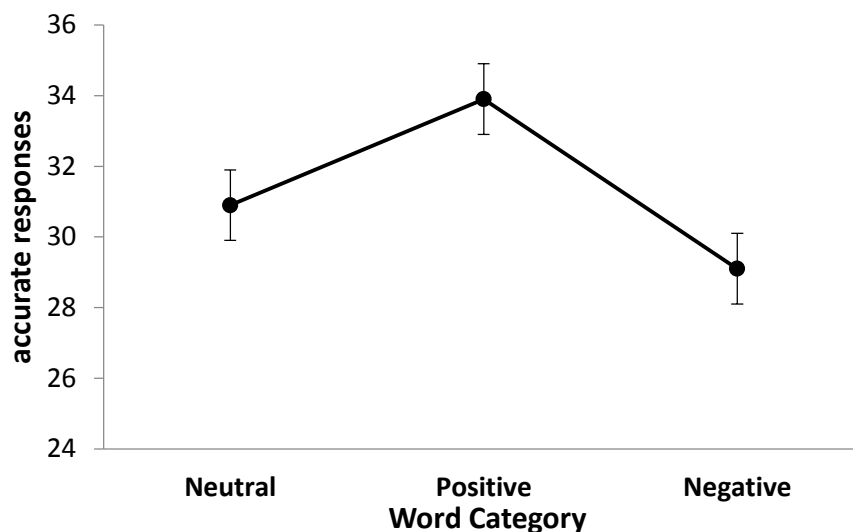

Figure 1: Accurate responses in word categories, the values are presented as Mean ± S.D. Reaction time: results indicated that there were not significant differences between reaction time in positive, negative and neutral words by Greenhouse-Geisser test ( $F(1.23,11.03)=2.25$ ;  $P=0.160$ ). But the mean of reaction time in negative words was more than positive and neutral words (figure 2).

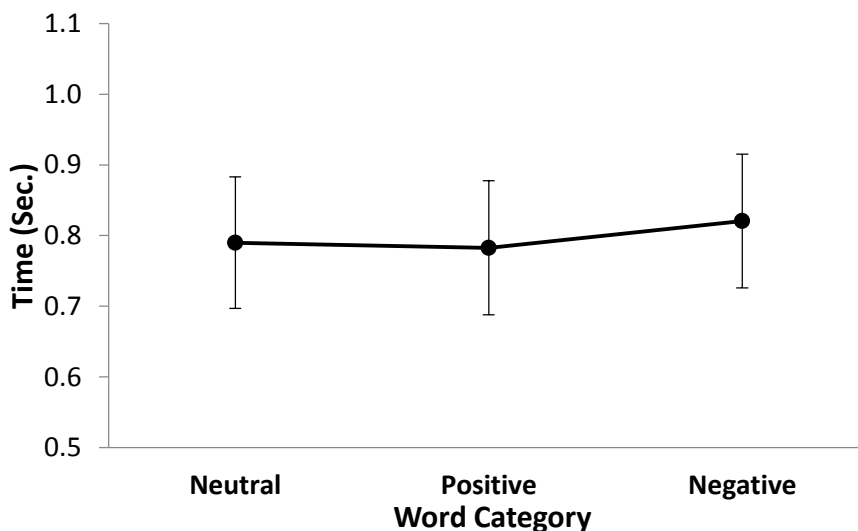

Figure 2: Reaction time in word categories, the values are presented as Mean ± S.D.

**Electrophysiological results:** this section including topographic and plots which analyzed by visual inspections. Statistical analysis also was conducted in amplitude values.

**Topographic results:** as seen in figure4, activity in posterior regions is more than other regions in all categories in reading task. But, active regions in posterior for neutral words are larger than emotional words. On the other word, there is diffused activity in emotional words in the brain. There is more and focused activity in right frontal in positive words.

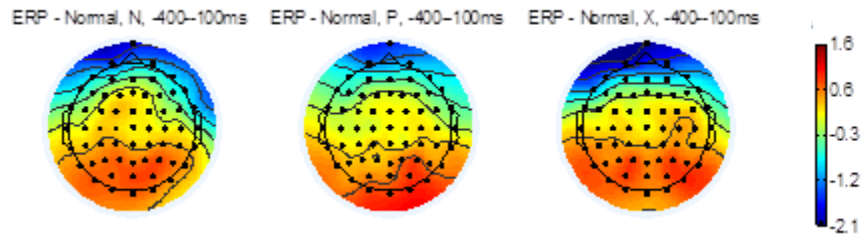

Figure 3: topography of emotional and neutral words in reading aloud task

Plot results: As seen in figure3, scalp was divided into 11 regions according to recording wave patterns. Amplitude and latency will be analyzed in each region.

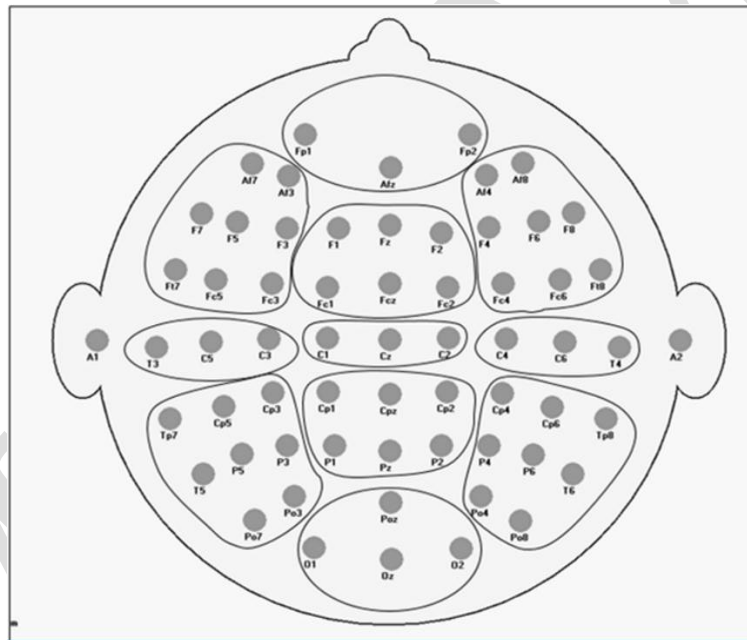

Figure 4: Scalp regions

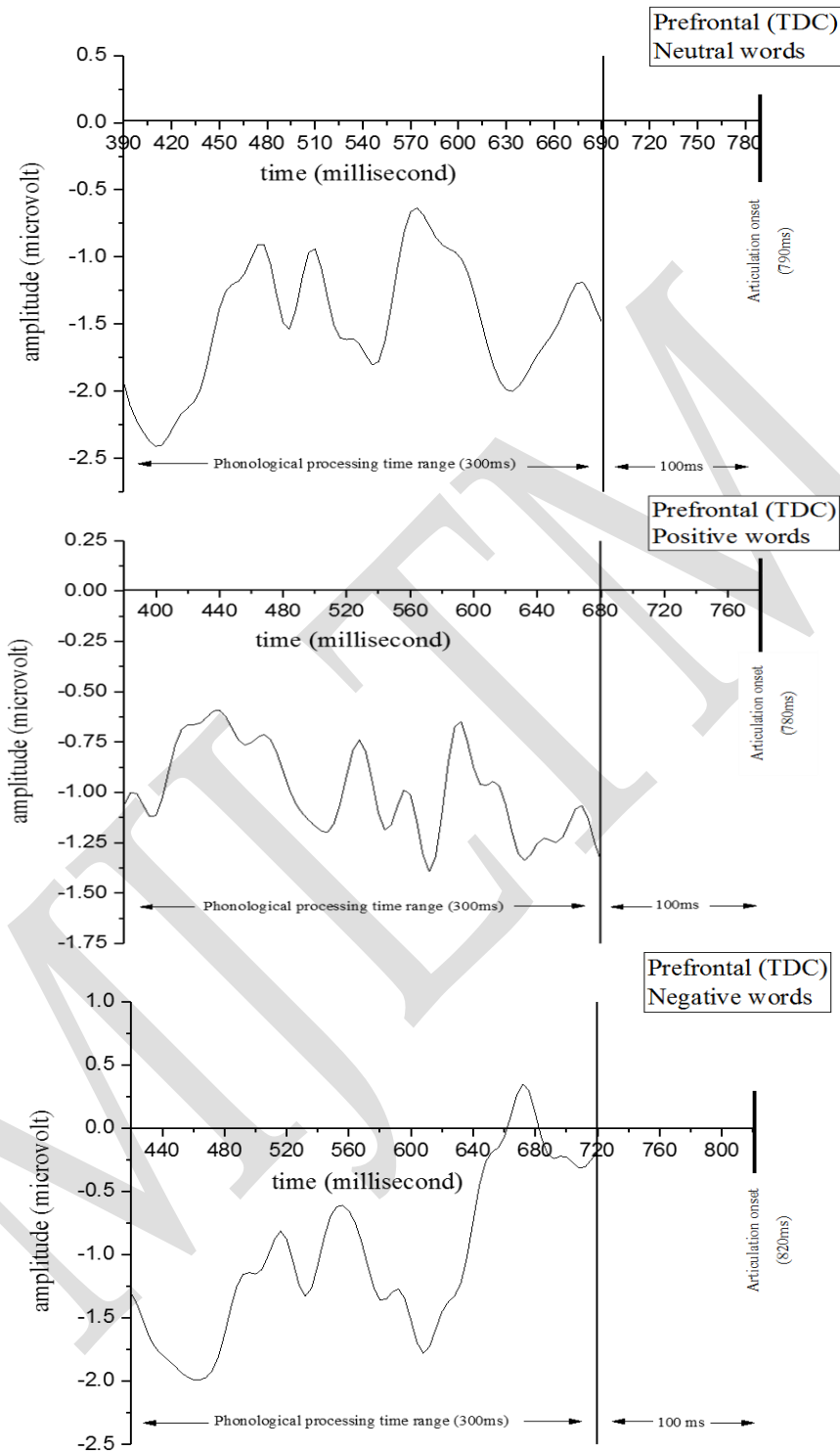

Chart 1: Average ERP waveforms in Prefrontal region for three word categories

As seen in chart1, all charts have a valley in beginning in prefrontal region. There is more fluctuations with larger amplitude in positive words in prefrontal. However, the fluctuations is nearly the equal in negative and neutral words and they have similar pattern.

ACCEPTED

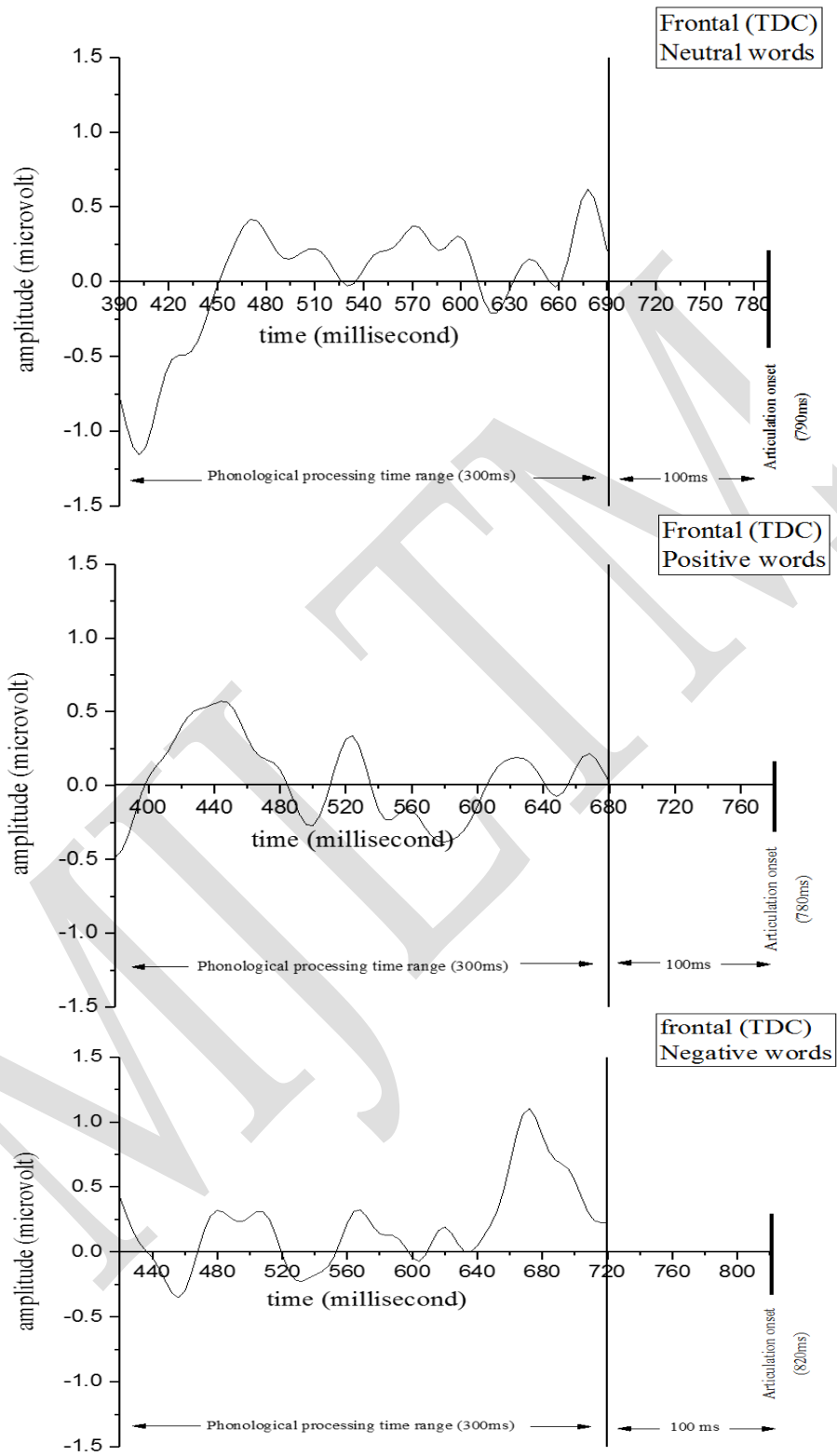

Chart 2: Average ERP waveforms in frontal region for three word categories



As seen in chart 2, all categories have similar fluctuations in frontal region. The amplitude of these peaks is larger in positive words. Negative words pattern were different from neutral and positive words at the end of recording near to articulation.

ACCEPTED

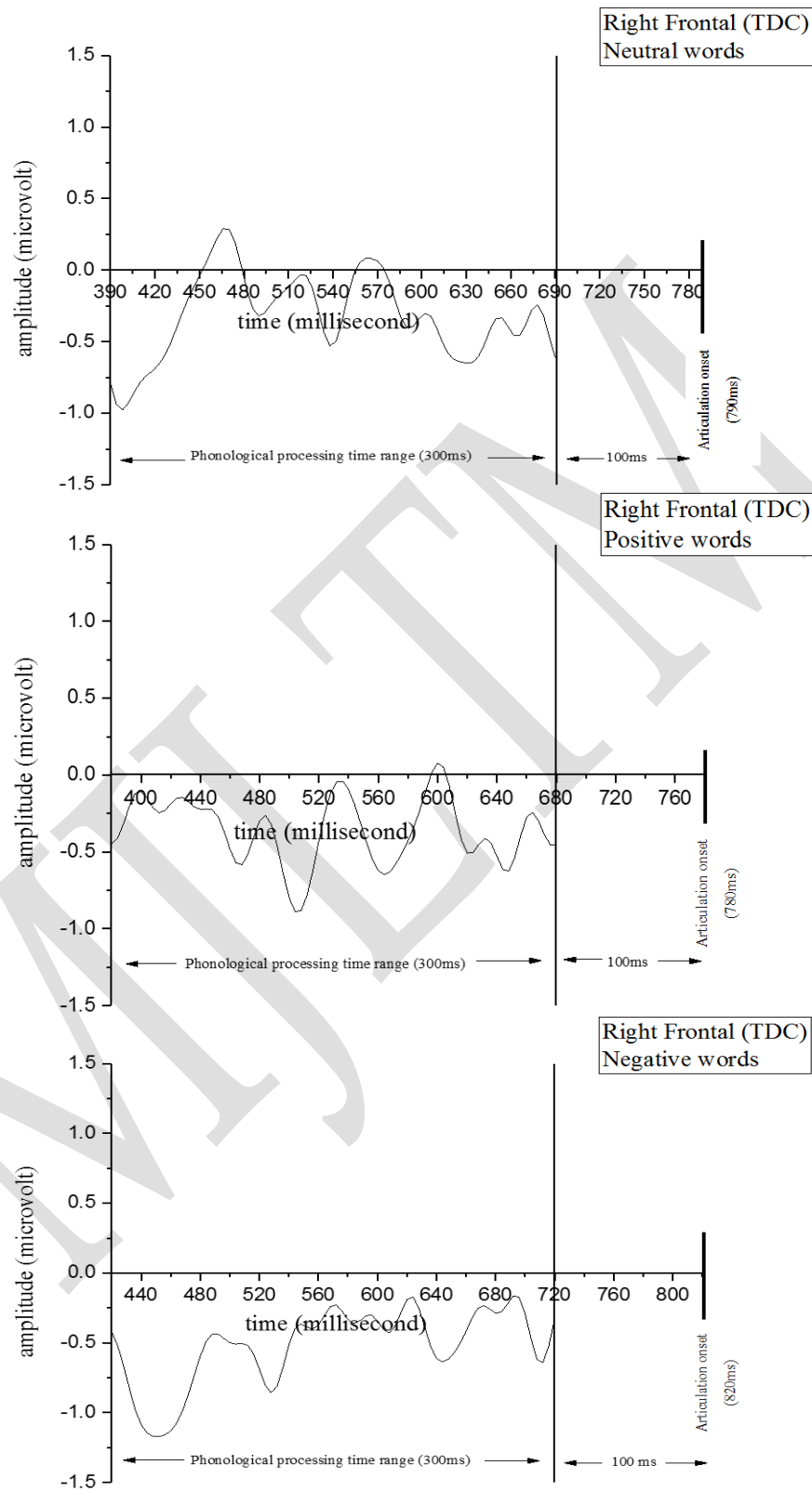

Chart 3: Average ERP waveforms in right frontal region for three word categories

As shown in chart 3, there is fluctuations in recording waves in all word categories in right frontal region. Although, more fluctuations are recorded in positive words and the peaks and valleys have larger amplitude in positive words in right frontal (motor) region.

ACCEPTED

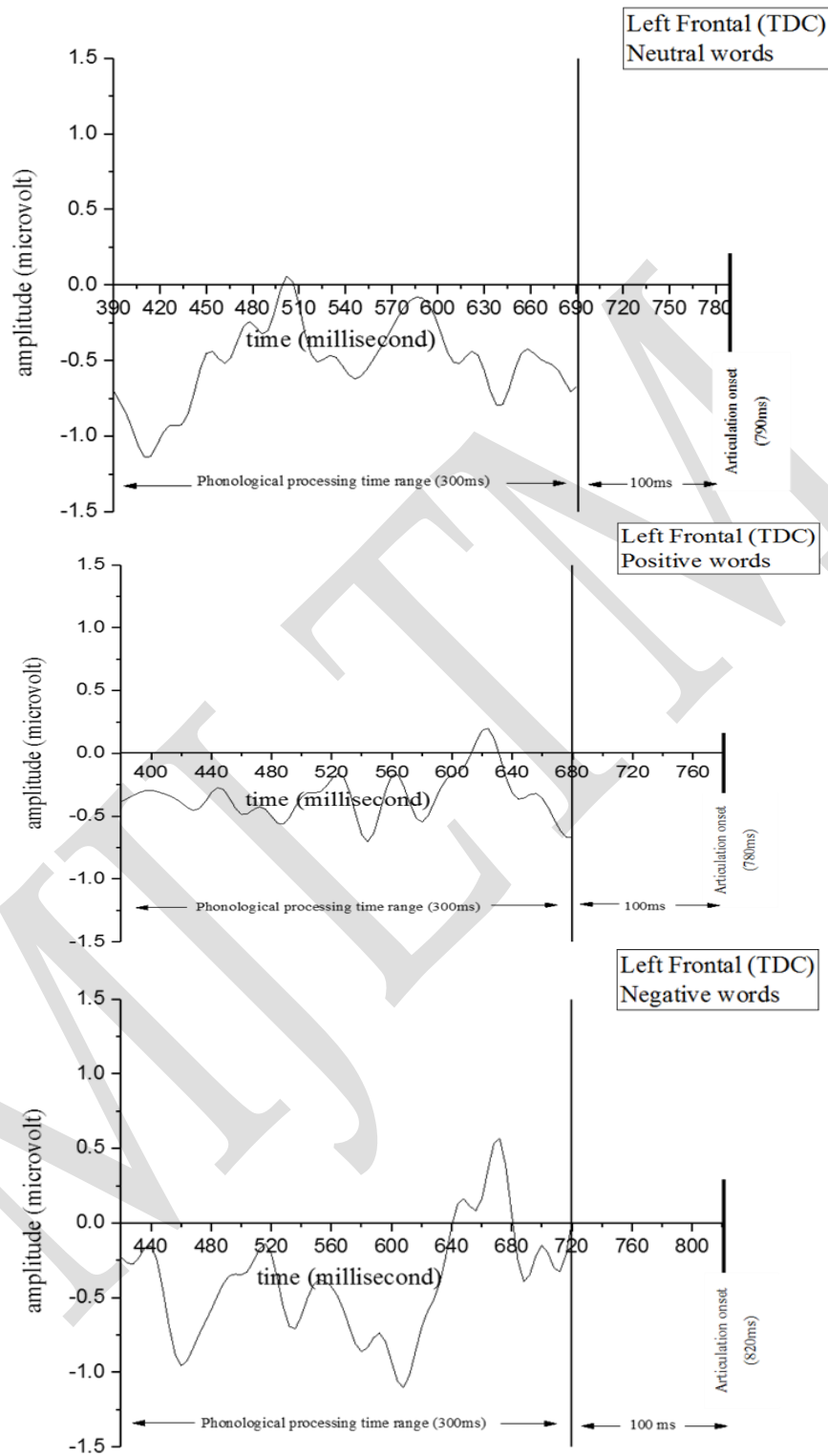

Chart 4: Average ERP waveforms in left frontal region for three word categories

Chart 4 illustrated that positive and negative words have approximately similar pattern with the equal number of peaks and valleys in left frontal and it is differ from neutral words. Also negative words has larger peak to peak distance, from +0.5 microvolt to -1 microvolt.

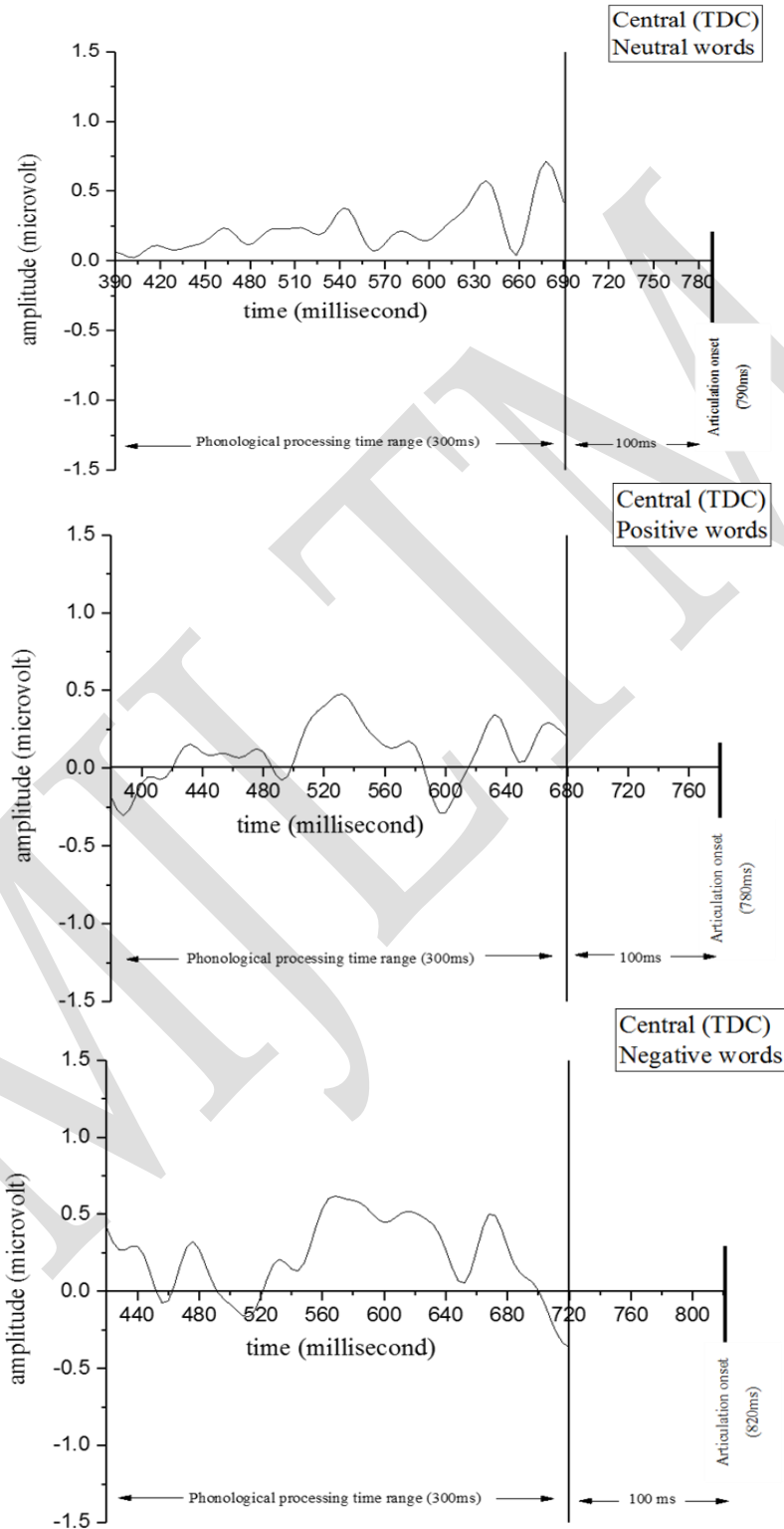

Chart 5: Average ERP waveforms in central region for three word categories

Chart 5 shows that emotional words have the same fluctuation in central region. There is larger amplitude and peak to peak distance in positive words, ranged from +0.5 to -0.3. Neutral words have smaller amplitude until about 620 ms, after that larger amplitude is appeared.

WILEY

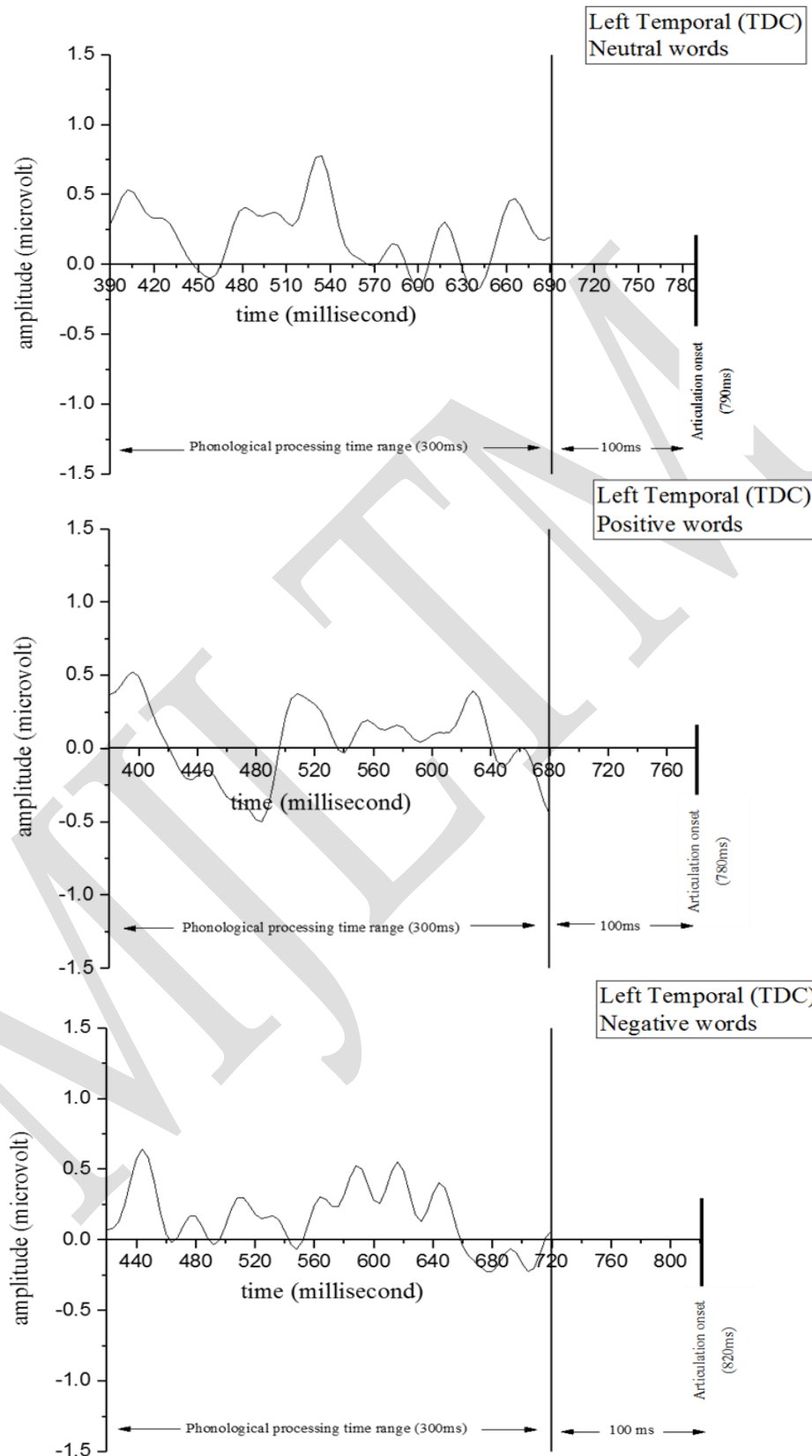

Chart 6: Average ERP waveforms in left temporal region for three word categories

As illustrated in chart 6, negative words have totally different pattern with more fluctuations in left temporal regions. On the other hand, positive and neutral words have relatively similar fluctuation with equal number of peaks and valleys with larger amplitude in positive words. Peak to peak distance is larger in positive words.

WATERM



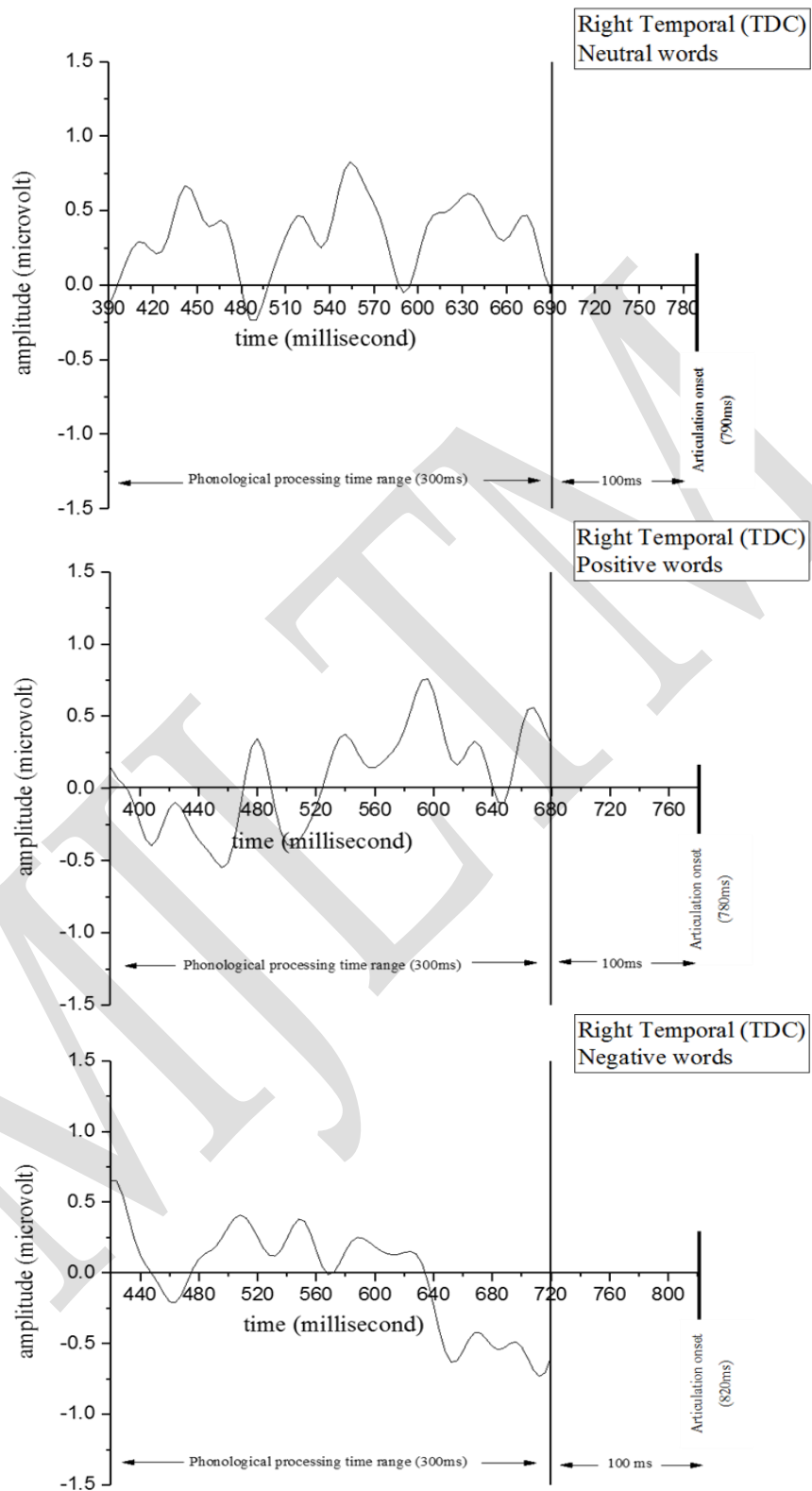
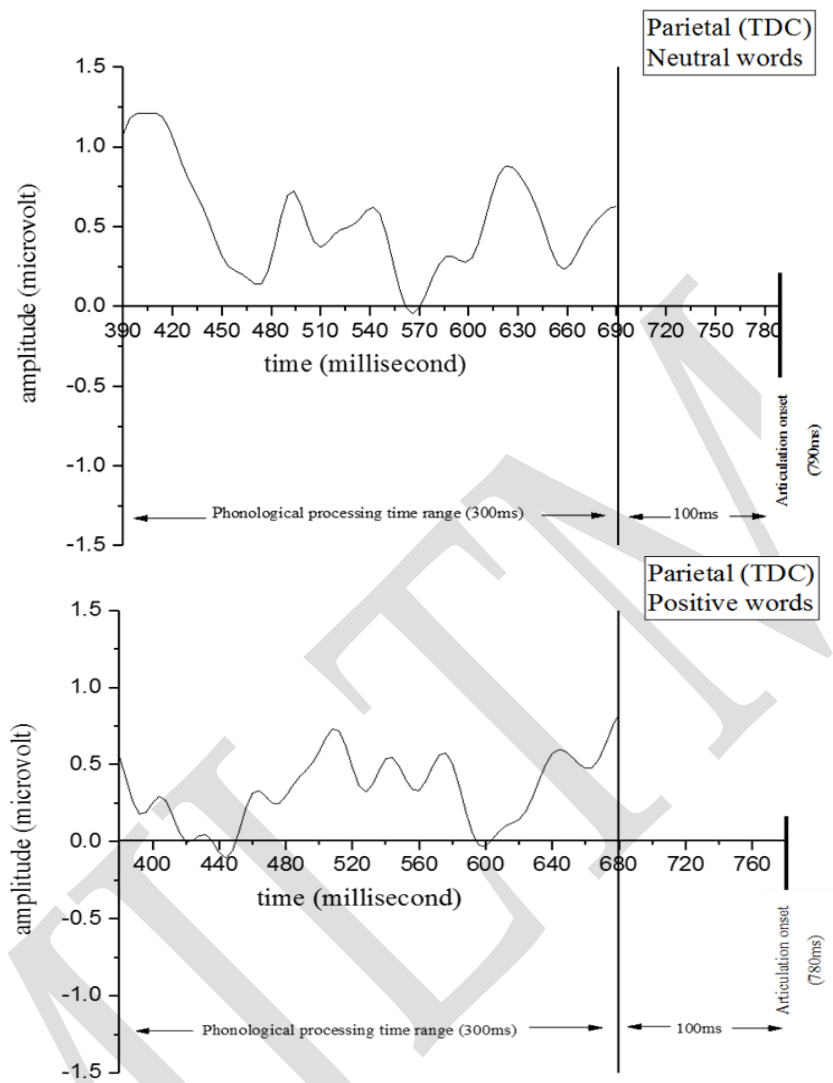

Chart 7: Average ERP waveforms in right temporal region for three word categories

As seen in Chart 7, right temporal activity in neutral words is completely differ from emotional words with more fluctuations. Positive words have larger fluctuation amplitude and peak to peak distance, ranged from +0.8 to -0.6.

WATERM



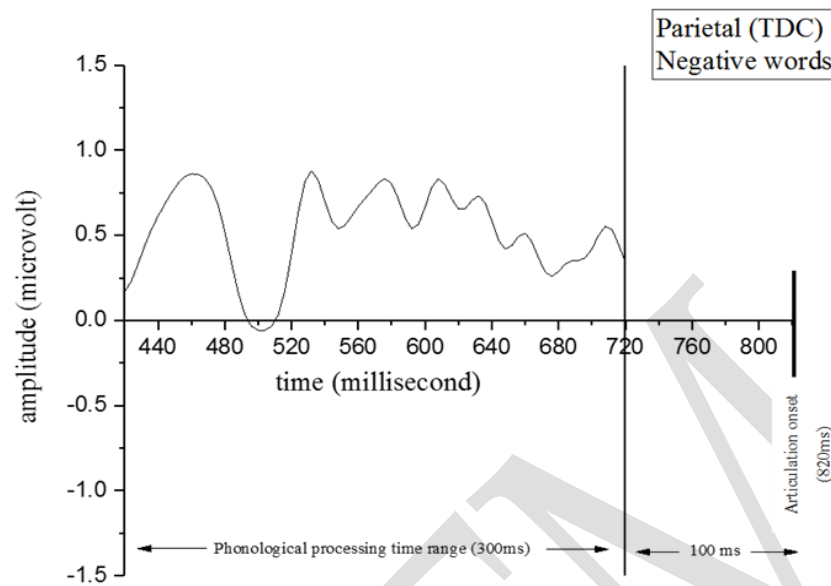
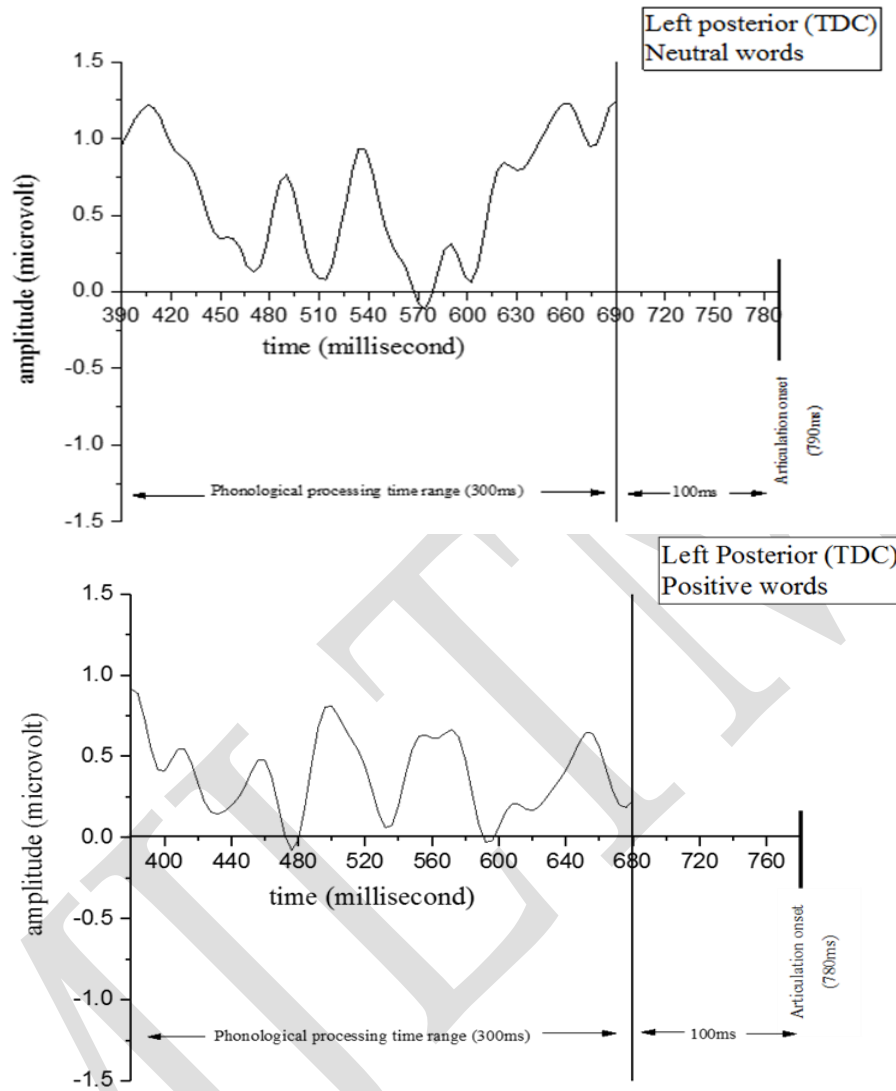

Chart 8: Average ERP waveforms in parietal region for three word categories

As shown in chart 8, there is difference in the number fluctuations in neutral, negative and positive words in parietal region. It is seen a positivity around 500 ms (P500) in neutral and positive words, while there is a negativity in negative words in this latency. Generally, there are some fluctuations in recorded waves in all word categories and the amplitude and peak to peak distance are larger in neutral words.



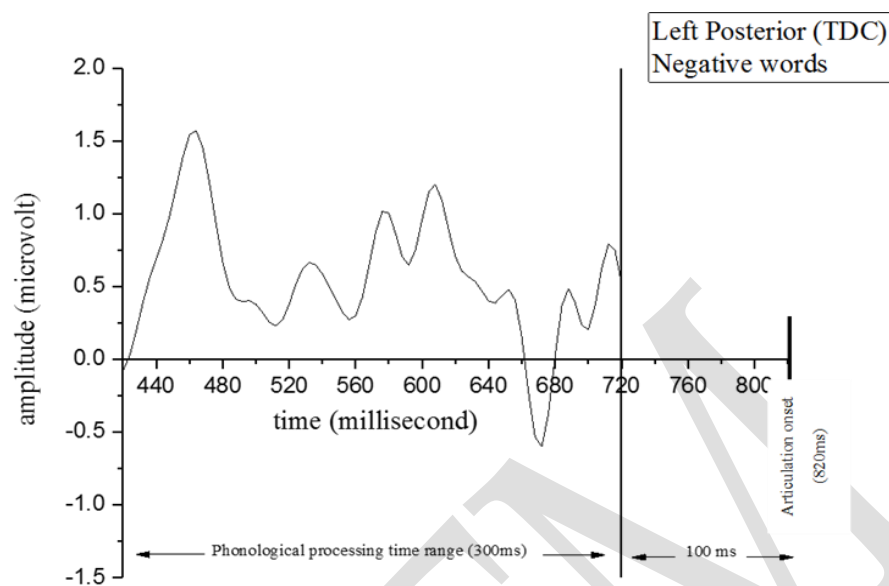
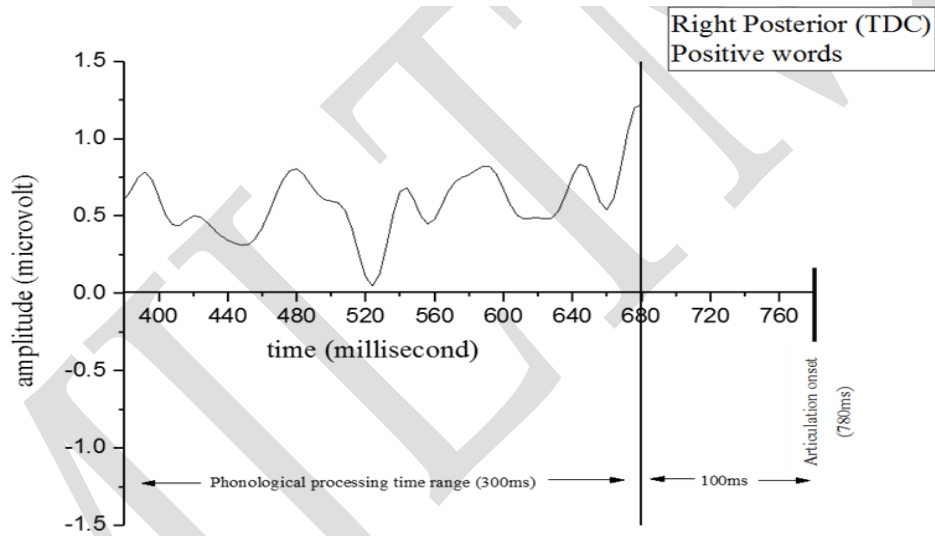
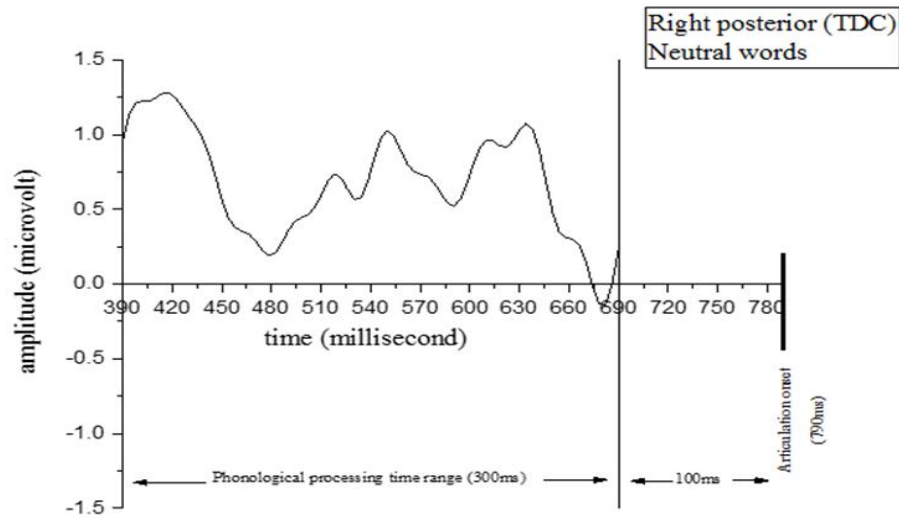

Chart 9: Average ERP waveforms in left posterior region for three word categories  
 Chart 9 illustrated that neutral and positive words have similar pattern of fluctuations with larger amplitude in neutral words in left posterior region. Negative words have the largest peak to peak distance, about 2. There is reverse pattern in negative words at the end of wave, near to articulation.



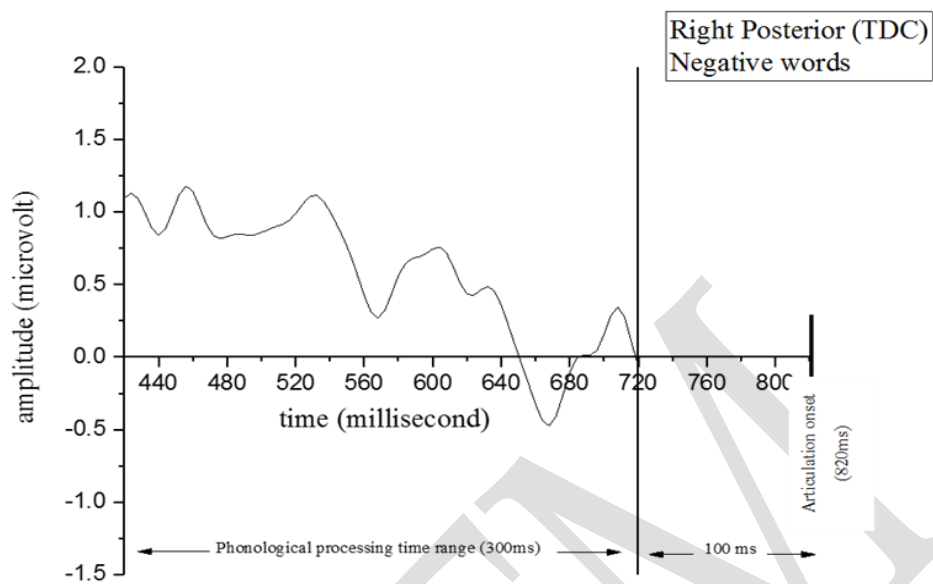

Chart 10: Average ERP waveforms in right posterior region in for three word categories  
 Chart 10 shows that negative and positive words have relatively similar fluctuations pattern near to articulation, positive words has larger amplitude. However, reverse pattern is seen in neutral words.



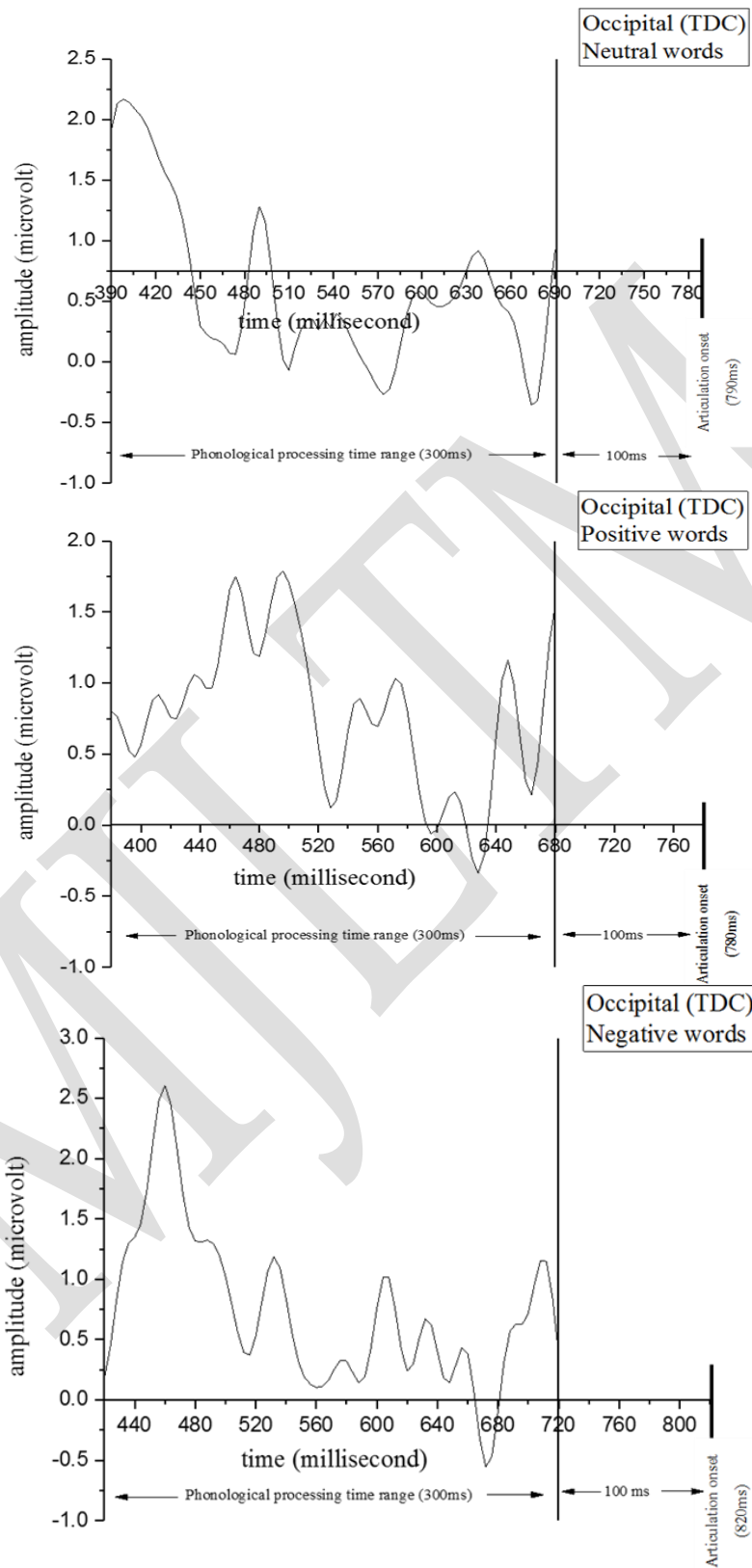

Chart 11: Average ERP waveforms in occipital region for three word categories

As seen in chart 11, there is many fluctuations in all word categories, such as a positivity in negative and positive words around 460 ms, the reverse pattern is seen in neutral words. Fluctuations in positive words have larger amplitude.

As seen in table 1, differences between word categories is significant in prefrontal and right posterior. Multiple comparison showed that positive words have smaller amplitude in right posterior. Absolute value of amplitude is larger in positive words in prefrontal.

Table 1. Comparison between word categories and regions

	Word Category			P†	Pairwise comparisons
	Negative (N)	Positive (P)	Neutral (Neu)		
<b>Min</b>					
Prefrontal	-3.78 (2.57)	-4.23 (2.78)	-3.15 (1.89)	0.033	Neu  <  P
Frontal	-1.74 (1.22)	-1.6 (0.78)	-1.9 (0.83)	0.643	-
Right Frontal	-2.26 (0.94)	-2.29 (1.03)	-2.00 (0.97)	0.573	-
Left Frontal	-2.35 (0.99)	-2.17 (0.80)	-2.77 (0.80)	0.103	-
Central	-1.60 (0.75)	-1.40 (0.96)	-1.59 (0.71)	0.737	-
Left Temporal	-1.56 (0.77)	-1.57 (0.41)	-1.40 (0.76)	0.680	-
Right Temporal	-2.07 (0.84)	-1.59 (0.60)	-1.84 (0.77)	0.345	-
Parietal	-1.38 (0.76)	-1.36 (0.77)	-1.24 (0.63)	0.875	-
Left Posterior	-1.67 (1.48)	-1.66 (1.04)	-1.29 (1.33)	0.527	-
Right Posterior	-1.77 (1.23)	-1.18 (0.84)	-1.57 (1.35)	0.437	-
Occipital	-2.24 (1.61)	-2.68 (1.58)	-2.05 (0.88)	0.512	-
<b>Max</b>					
Prefrontal	1.71 (1.28)	1.31 (1.45)	1.06 (1.64)	0.303	-
Frontal	1.89 (0.87)	1.77 (0.85)	1.91 (0.37)	0.876	-
Right Frontal	1.16 (0.76)	1.54 (0.96)	1.03 (0.63)	0.545	-
Left Frontal	1.50 (0.96)	1.50 (0.59)	1.42 (0.71)	0.924	-
Central	1.88 (0.89)	1.41 (1.24)	1.82 (1.18)	0.373	-
Left Temporal	1.91 (1.33)	1.56 (0.70)	1.91 (0.84)	0.333	-
Right Temporal	1.70 (0.68)	1.87 (0.67)	2.23 (1.07)	0.167	-
Parietal	2.32 (1.16)	1.91 (1.21)	2.44 (1.24)	0.351	-
Left Posterior	2.78 (1.64)	2.57 (1.06)	2.70 (1.02)	0.662	-
Right Posterior	3.12 (1.07)	2.28 (1.16)	2.88 (1.35)	0.013	P < N, Neu
Occipital	3.83 (1.69)	3.83 (2.20)	3.39 (1.41)	0.518	-

Values are given as Mean (SD)

†Repeated Measures ANOVA

**Discussion:**

The main aim of present study was investigation of phonological processing (-100,-400 ms before onset of articulation) in emotional words and neutral words in normal Persian speaking children. Our data analysis showed that positive words (high valence) have the most accurate words, after that neutral words and finally negative words (low valence). It suggested that high valence words are recognized more accurate than neutral and low valence words. As well as, Positive words have smaller RT than negative words. On the other words, high valence words are recognized faster than low valence words. These results is consist with the results of study which emphasize on importance of valence on word recognition[7]. Apparently, pleasant words are better recognized.

We found that there is larger amplitude in positive words in prefrontal, frontal, right frontal and left frontal (anterior) areas by visual inspection. Larger amplitude is seen in central for neutral words. These results of Persian speaking children with reading task are in the line with the results of Polish speaking adults with reading task [8]. Also larger amplitude indicated more neural activity in positive words in

anterior areas, which are motor regions. Then, it seems that high valence words have more neural activation in phonological processing in speech motor and emotional areas. It could be why high valence words are better recognized. Right temporal, right posterior, left temporal and occipital have also larger amplitude in positive words. Topography also showed diffuse activity in emotional words in brain. These are consist with the results of other studies which declare emotion enhances brain activity [9, 12]. Then emotion likely increase language processing in some regions in the brain.

Conversely, emotional content helps to phonological processing and emotional content words have smaller amplitude in central region. It can be explained by minimum involvement of central regions in speech processing in reading task [22].

P1, P2, N1 and N2 were not recorded in the time range which is defined in the present study as phonological processing time.

As said in results, negative words (low valence) were totally different in left temporal and left posterior regions which are involved in phonological and conceptual processing[22]. It is suggested that low valence words might be completely different in conceptual and phonological processing.

There were significant difference between negative, positive and neutral words in prefrontal and right posterior. Positive words had significantly larger amplitude in prefrontal region and significantly smaller in right posterior region. Low valence increase the amplitude in right posterior region. It is the only region which shows increasing with low valence. This results is not consist with other studies which suggested that high valence enhances amplitude[12]. It might be have been due to the task, reading[22]. Prefrontal has role in complex cognitive and speech monitoring[23], more significant prefrontal activity in positive words maybe shows that emotion has significant effect on word processing in this region.

**Acknowledgement:** we would like to thank to signal processing section in National Brain Mapping Lab (NBML) for helping us to analyze the recording ERP.

#### Appendix 1: Range Of Interest (ROI)

Prefrontal: Fp1, Afz, Fp2

Frontal: F1, Fz, F2, Fc1, Fcz, Fc2

Right frontal: Af4, Af8, F4, F6, F8, Fc4, Fc6, Ft8

Left frontal: Af7, Af3, F7, F5, F3, Ft7, Fc5, Fc3

Central: C1, Cz, C2

Left temporal: T3, C5, C3

Right temporal: T4, C4, C6

Parietal: Cp1, Cpz, Cp2, P1, Pz, P2

Left posterior: Tp7, Cp5, Cp3, T5, P5, P3, Po7, Po3

Right posterior: Cp4, Cp6, Tp8, P4, P6, T6, Po4, Po8

Occipital: Poz, O1, Oz, O2

#### References:

1. Kotz SA and Paulmann S. Emotion, Language, and the Brain. *Lang Linguist Compass*, 2011. **5**(3): p. 108-125.
2. Vinson D, Ponari M and Vigliocco G. How does emotional content affect lexical processing? *Cognition & Emotion*, 2014. **28**(4): p. 737-746.
3. Russell JA, Bachorowski JA and Fernandez-Dols JM. Facial and vocal expressions of emotion. *Annu Rev Psychol*, 2003. **54**: p. 329-49.
4. Kensinger EA. Remembering emotional experiences: the contribution of valence and arousal. *Rev Neurosci*, 2004. **15**(4): p. 241-51.
5. Adolphs R, Damasio H and Tranel D. Neural systems for recognition of emotional prosody: a 3-D lesion study. *Emotion*, 2002. **2**(1): p. 23-51.

6. Banich MT and Mack M. *Mind, Brain, and Language: Multidisciplinary Perspectives*. 2003: Taylor & Francis.
7. Kuperman, V, Estes Z, Brysbaert M and Warriner AB. Emotion and language: valence and arousal affect word recognition. *J Exp Psychol Gen*, 2014. **143**(3): p. 1065-1081.
8. Imbir KK, Jarymowicz MT, Spustek T, Kuś R and Żygierewicz J. Origin of Emotion Effects on ERP Correlates of Emotional Word Processing: The Emotion Duality Approach. *PLOS ONE*, 2015. **10**(5): p. e0126129.
9. Yao Z, Yu D, Wang L, Zhu X, Guo J and Wang Z. Effects of valence and arousal on emotional word processing are modulated by concreteness: Behavioral and ERP evidence from a lexical decision task. *Int J Psychophysiol*, 2016. **110**: p. 231-242.
10. Kissler J, Herbert C, Peyk P and Junghofer M. Buzzwords: early cortical responses to emotional words during reading. *Psychol Sci*, 2007. **18**(6): p. 475-80.
11. Bernat E, Bunce S and Shevrin H. Event-related brain potentials differentiate positive and negative mood adjectives during both supraliminal and subliminal visual processing. *Int J Psychophysiol*, 2001. **42**(1): p. 11-34.
12. Hinojosa JA, Mendez-Bertolo C, Carretie L and Pozo MA. Emotion modulates language production during covert picture naming. *Neuropsychologia*, 2010. **48**(6): p. 1725-34.
13. Laganaro M. ERP topographic analyses from concept to articulation in word production studies. *Frontiers in Psychology*, 2014. **5**: p. 493.
14. Levelt WJM. Spoken word production: A theory of lexical access. *Proceedings of the National Academy of Sciences*, 2001. **98**(23): p. 13464-13471.
15. Laganaro M and Perret C. Comparing electrophysiological correlates of word production in immediate and delayed naming through the analysis of word age of acquisition effects. *Brain Topogr*, 2011. **24**(1): p. 19-29.
16. Wagner RK and Torgesen JK. The nature of phonological processing and its causal role in the acquisition of reading skills. *Psychological Bulletin*, 1987. **101**(2): p. 192-212.
17. Ponz A, Montant M, Liegeois-Chauvel C, Silva C, Braun M, Jacobs AM, Ziegler JC. Emotion processing in words: a test of the neural re-use hypothesis using surface and intracranial EEG. *Social Cognitive and Affective Neuroscience*, 2014. **9**(5): p. 619-627.
18. Oldfield RC. The assessment and analysis of handedness: The Edinburgh inventory. *Neuropsychologia*, 1971. **9**(1): p. 97-113.
19. Nazari MA, Khayati F, Poursharifi H, Hakimi M, Shojaei Z. Primary Normalization of Emotional Farsi Words. *Applied Psychological Research Quarterly*. 2014, **4**(4), p. 41-71.
20. Hunt MJ. Spectral Signal Processing for ASR, in *IEEE ASRU Workshop*. 1999.
21. Bigdely-Shamlo N, Mullen T, Kothe C, Su KM and Robbins KA. The PREP pipeline: standardized preprocessing for large-scale EEG analysis. *Frontiers in Neuroinformatics*, 2015. **9**: p. 16.
22. Hickok G. The Functional Neuroanatomy of Language. *Physics of life reviews*, 2009. **6**(3): p. 121-143.
23. Riès SK, Xie K, Haaland KY, Dronkers NF and Knight RT. Role of the lateral prefrontal cortex in speech monitoring. *Frontiers in Human Neuroscience*, 2013. **7**: p. 703.

## The Rhetorical Preference of Quran's Different Chapters

Mehrnoosh Eslami<sup>1</sup>

<sup>1</sup>Department of Letters and Humanities, Faculty of Foreign Languages and Linguistics, University of Shiraz, Eram st., Shiraz, Iran

Seyyed Fazel Fazeli<sup>2</sup>

Department of Letters and Humanities, Faculty of Foreign Languages and Linguistics, University of Shiraz, Eram st., Shiraz, Iran

Naser Rashidi

Department of Letters and Humanities, Faculty of Foreign Languages and Linguistics, University of Shiraz, Eram st., Shiraz, Iran

### Abstract

The present study attempts to investigate the rhetorical preference of different chapters of holy Quran to determine whether all chapters of Quran follow one or more specific profile patterning identified in Chesterman's (1988) model of rhetorical analysis and check which profile can be the main rhetorical preference of Quran's Chapters. The necessary data for the study were collected from a sample of the two dichotomies of Long/Short and Makki/Madani Chapters in the whole Book (Approximately 23% of the whole book). Chesterman's (1988) model of rhetorical analysis was used to analyze the appropriate pattern of holy Quran. The results indicate that each chapter follows a specific profile according to Chesterman's model, however linearity (81%), listing (12%) and parallelism (7%) were the dominate profile among the analysed chapters.

**Keywords:** Chesterman's model, rhetorical profile, Quran's rhetorical preferences, Makki/Madani Chapters of Quran

### 1. Introduction

#### 1.1. Chesterman's model

Chesterman (1988) introduced some different patterns of writing or profile of a text as Linear, Parallel, Spiral, Scatter, Digressive and Listing although as he stated they are endless in number. Different studies were done on different languages to determine their specific rhetorical preferences. However, no study has explored the same issue on the holy book Quran. Therefore, Chesterman categories are explained to see what characteristics they have.

1.1.1. **Linearity** Two main features are the basic elements of this style, namely, unity and avoidance of repetition. Whenever, one single main theme is maintained in an essay and also one main idea expressed in each paragraph, the writing style is linear since it has unity. However if two main ideas are provided in each paragraph, that writing has a non-linear writing style and may follow the features of digression and indirection. In contrast to nonlinear pattern which are specified by repetition, linearity seldom uses repetition except for strengthening the tone of the writing to enhance persuasiveness.

In Monroy and Scheu, (1997, cited in Monroy, 2008) some guidelines are established for a straight linear rhetorical pattern.

1) Thematic Unit (TU). This category is called to be present whenever there is only one thesis in an essay in a way that it binds all parts to a single main idea.

2) Thematic Progression (TP). This category is called to be present whenever the writer provides a relationship between all thematic sentences in each paragraph with the main thesis.

3) Paragraph Unity (PU). This category is called to be present whenever the writer provides a monothematic structure and not a polythematic one, in a way that all sentences develop the controlling idea through expanding and illustrating it.

4) Personal tone (PT). According to Hinds (1987, cited in Monroy, 2008) this category refers to consistent point of view; writers responsible vs. reader responsible languages.

5) Inter-paragraph cohesion (CO). This category is called to be present whenever there are linkages between paragraphs in a co-referential, co-classification or co-extensive way.

6) Concreteness (CON). This category is called to be present whenever the tendency is toward using more concrete words rather than abstract words.

7) Sentence Simplicity (SS). This category is called to be present whenever the writer makes use of more simple and coordinate sentences rather than complex or subordinate sentences. Therefore we can say that a writing style follows the pattern of linearity if it has the above mentioned characteristics. Different studies such as Kaplan (2000) proved that English follows the pattern of linearity since it obeys the entire above mentioned characteristic.

### 1.1.2. Digression

Digression can be strategically used for additional information, suggesting alternative possibilities or it can be used as a hedging device and also for the purpose of humor. Digressions may be deemed "irrelevant to the topic", "getting off the track", or "inappropriate to the context" in the context of academic writing.

Discontinuity as one of the features of Digressive style in an essay means to leave an argument somewhere in the air and to start another new argument, as defined by Clyne (1987). It is often together with indirection or digression. The argument being left unfinished is either forgotten or continued later in the essay. Kachru (1988) provided three main features of Hindi writing since this language follows the pattern of digression. The First feature is that "unity of topic is not a requirement for a paragraph" (p.116); Moreover, "claim and its justification may be presented in separate paragraphs while material related to the background may be presented in the same paragraph as the claim" (p.116), and the last feature is that there is "no need for an explicit topic statement in a paragraph" (p.116).

In addition to Hindi language, French and German follows the pattern of digressive style. According to Clyne (1987), in German writing digression mainly occurs to provide background information, give analysis or comments on side-track topics.

### 1.1.3. Listing

In listing as one type of writing style, all of the predications which are co-ordinated are subordinated to a single predication, as in [P1] IF [P2] AND [P3] AND [P4] etc. In this profile, the first paragraph has a marked listing profile, stating the conditions, and the same profile dominates again at the end of the text. Moreover, this style is mostly used in legislative provisions (Chesterman, 1998). Chesterman argues that a Thai rhetorical preference is "listing" since this style is frequent in Thai folk literature.

### 1.1.4. Parallelism

Chesterman (1998) stated that in the pattern of parallelism, the texts "proceeds in a series of balanced pairs of predications, for instance reflecting contrasts or different facets of a single theme" (p.172). He stated that this pattern is mostly used in argumentative text type in English. In his book, Ostler (1987) indicates that Arabic language follows the pattern of parallelism.

### 1.1.5. Spiral

In the spiral style "the text circles into or away from its Point in different directions, and is characterized by a lack of sequential cohesion" (Chesterman, 1998, p.172). In other words, the central idea comes first and then additional information is stated in sentences that "might have been placed in several other orders". (Chesterman, 1998, p.172).

### 1.1.6. Scatter

In the scatter style, the ideas in the text are scattered without much cohesion and the actual main idea remains so ambivalent (Chesterman, 1998). However, no specific language follows the pattern of scatter as a dominant profile and they may appear in different writings as a subordinate profile of a text.

## 1.2. Quran's pattern

In fact, Holy Quran Chapters can be identified and categorized in two broad categories of Makki (M) and Madani (MD) elaborated in the following section.

### 1.2.1. Makki Chapters

These Chapters are those revealed to Muhammad (PBUH) in Mecca at the beginning of his Mission. As far as the subject matter of these Chapters is concerned, they are mostly about the clarification of Islamic Beliefs, the Principles of Islam, the rejection of *Sherk*, and the belief in holy divine Messengers and Hereafter (Marefat, 1999).

### 1.2.2. Madani Chapters

Later on, at the middle and the end period of holy Muhammad's life, these Chapters were revealed to him in Medina. These Chapters are mostly about the clarification of Social Behaviors and rules, Allah's commandments and laws, and Islamic Minutiae (Marefat, 1999).

Recently, more attempts were made in analyzing different aspects of holy Quran. Hence, a better understanding of rhetorical preference of holy Quran can help Quran discourse analyst who wants to know every single and detail aspects of each verses of it in order to provide a well-organized pattern behind different verses. It is hoped that the results of this study will serve as a useful starting point. Moreover, Quran content analysts and Quran interpreters justifying Quran's content by the profile patterns applied in it can gain benefit from the findings of this study. To the best of the researchers' knowledge, there has been no research regarding the rhetorical preference of holy Quran. This was the motive behind the present research. Therefore, the specific objective of the present study is to check the pattern of writing or profile of a text in the holy book Quran, to examine its specific rhetorical preferences. As such the following research questions are put forward in the present study.

1. Is Chesterman's (1988) framework of rhetorical profile patterning applicable to Quran? If so,
2. Do all Chapters of Quran follow one or more specific pattern identified by Chesterman's (1988)?
3. What profile patterning is commonly applied in Quran's Chapters?

## 2. Methodology

This section incorporates the information related to materials, the procedure of data collection and the procedure of data analysis.

### 2.1. Materials and the procedure of data collection

The materials of this study are taken from Holy Quran. First, Holy Quran, as a comprehensive source of information with enormous topics and situational phenomena, was investigated as a whole. In order to have a whole picture of the Quran and to observe the sample representative, we classify the Holy Book into two dichotomies of Long/Short and Makki/Madani Chapters. Four categories were prepared for our analysis including;

- 1- Long Makki (LM)
- 2- Long Madani (LMD)
- 3- Short Makki (SM)
- 4- Short Madani (SMD)

We reached the criterion for the length of the holy chapters dividing the number of the pages of the Holy Quran (604 - according to Osman Taha Version of Quran) to the number of the Holy Chapters (114). It gives  $604/114= 5.2$ . Therefore, the Holy Chapters that include less than five pages are considered short and those that include more than five pages are considered as long chapters.

Therefore, each of the above-mentioned categories of Quran Chapters exist in the following numbers  
1- LM (27)    2- LMD (9)    3- SM (60)    4- SMD (18)

In order to choose an equal percentage of each of the above-mentioned categories relative to the number of the Holy Chapters, we took the category of LMD (the least=9) as the unit of our choice. Other categories then were divided into 9 reaching the number of unit(s) that they include. Two units (each one per nine) were randomly chosen from each category. Consequently, the final step of our data collection procedure gives us the following categories:

- 1- LM (6 Chapters)
- 2- LMD (2 Chapters)
- 3- SM (14 Chapters)

#### 4- SMD (4 chapters)

It is worth mentioning that the data selected for our analysis (26 out of 114 Chapters) incorporates approximately 23% of the whole data (Holy Quran).

#### 2.2. Procedure of data analysis

For the analysis of the above-explained data, this study made use of Chesterman's (1988) model of rhetorical analysis. In other words, different chapters of Quran were analyzed to fit in one of Chesterman's model of Linearity, Parallelism, Spiral, Scatter, Digression and Listing. The analysis of this data was carried out by three researches who are MA TEFL and Arabic literature students. Each of the researchers analyzed the data by him/herself. Then, they gathered in a discussion meeting for a group analysis of the data. The inter-rater reliability of the results was calculated indicating the reliability of 92.25.

The analysis of the data was carried out through the following steps:

- 1- Each of the selected Holy Chapters was analyzed determining their topic sentences (main point), supporting body and conclusion. It was also sought if the topic sentence of each Chapter was repeated in other parts of the Chapter;
- 2- According to the above-mentioned framework of Chesterman (1988), the profile of each Chapter was determined;
- 3- In order to find the interrelationships existing between different Quran's chapters, the obtained profile of each Chapter was compared with the profile of other Chapters of the same category (for example, the identified profiles of all 14 chapters included in SM category are compared together). It was also tried to find a relationship between the topic of each Chapter and the profile of its Rhetorical model;
- 4- The profile (the dominant one) of each category was compared and analyzed with the profile of other categories (for example, the dominant profile(s) of SM category is compared with the dominant profile(s) of other category);
- 5- Finally the above-provoked research questions were discussed and answered based on the results and discussions of the study.

### 3. Results and Discussions

The results obtained in this study along with the related analyses and discussions are provided in this section. First, some instances of the results are discussed, and then the total results are presented in the table followed by the relevant discussions.

#### 3.1. Results

The following section incorporate the information related to the profile patterning of two Quran Chapters. The rhetorical profile patterning of these Chapters is more justified and explained by the elaboration of their subject matter and the order of subject(s) occurrence.

*The Holy Chapter of Zuxrof (Quran: 43)*

This chapter is *Makki* covering seven pages. Therefore, it is included in the first category of LM (Long Makki).

The main point (topic sentence) of this Chapter elaborates on the truth of Quran, Prophets, Hereafter (as divine Principles), and the warning against those who belie these principles. Referring to the Chapter, we see that Allah, from the very beginning, puts the most emphasis on these principles and warns believers against their evil deeds. At the primary Verses of this Chapter, Allah elaborates on these principles and put blame on those who are inattentive to them. In order to verify the point, Allah makes mention of ancient nations (The people of Holy Moses and Jesus) who belied divine principles and how they were seized by Allah's wrath. Finally, this Chapter reemphasizes the main point reminding Holy Muhammad that you should not be too in care of them, since they will not believe in divine principles but they will know very soon [the consequences of what they did] (43: 88-89).

As indicated by the above explanations, we see that this Chapter is elaborated and constructed, from the beginning to the end, in a strong content unity. All sections and sub-sections of this Chapter support a single main point. Nowhere in the Chapter can one detect any digression neither is changed the main



topic controlling the content of the chapter in any point of it. Therefore, this Chapter is constructed and elaborated in a linear pattern of profile supporting and verifying a single point of discussion.

*The Holy Chapter of Nur (Quran: 24)*

This Chapter is *Madani*. It covers ten pages, so it is one of the chapters included in the second category of LMD (Long Madani).

This Chapter presents some Divine commands legislated (in Chesterman’s (1988) words) by Allah for human life in a list of order. The commands are mostly about the conjugal and private life and how these issues to be observed and respected by others (strangers). The commands of different subjects are listed all over the Chapter. Some of the divine commands legislated in this Chapter include:

- 1- The list of commands related to fornication punishment and witnessing (24: 2-9)
- 2- The list of commands related to the necessity of asking permission for entering other’s houses (24: 27-29).
- 3- The list of commands related to marriage and casting veil (24: 30-33).
- 4- The list of commands related to asking permission for interrupting the conjugal privacy of others (24: 58-61).

According to the above-numerated lists of commands, we see that this Chapter follows the Listing profile according to Chesterman’s (1988, p.27) framework. It should also be mentioned that the Listing profile is not the only profile pattern applied in this chapter. Parallelism is the other profile that is found in this Chapter, although not as dominant as the Listing one. Mentioning the lists of commands, Allah, now and then, reminds the interlocutors of the difference between two opposite groups of those who are true believers observing the commands and those who show hypocrisy in their belief disobeying the commands. Some traces of Parallelism in this Chapter include;

- 1- The description of the life of those who are living according to the divine lights (commandments) and that of those who disobey the divine commands (24: 36-40).
- 2- The distinction between true/instable believers in terms of obeying/disobeying the divine commands (24: 47-57).

Therefore, we reach the conclusion that this Chapter follows a profile pattern of dominant Listing accompanied by a Parallel one. The profile of this Chapter can be introduced as Listing (Parallelism).

The following table presents other profile patterns of other Quran’s Chapters as follows;

**Table 1: The profile patterning of holy Quran’s Chapters**

Categ.	Chapters	Page Numbers	Main point	Profile
LMD	Ma-e-de (5)	13	Observing Allah’s mottos/ commitments	Listing (Spiral)
LMD	Nur (24)	6	Divine commands and the way true/false believers approach them	Listing (Parallel)
SMD	Jom-e (62)	1	To prefer Allah’s affairs to all others and the consequences of the neglectful ones	Linear
SMD	Næs-r (110)	1	The victory of Allah’s religion and the necessity of being thankful for it	Linear
SMD	Ho-jor-at (49)	2	To be obedient to Allah and his Messenger	Listing
SMD	Mom-tæ-hene (60)	2	How to make relationship with friends and enemies	Linear(listing-parallel)
LM	Yun-os (10)	7	The truth of <i>Vahy</i> and the consequences of belying or believing in it	Linear (parallel)
LM	Saffat (37)	5	The oneness of Allah and the consequences of <i>Sherk</i>	Linear

LM	ænkæbut (29)	5	Believing in Allah requires taking pains and hardships for Him	Linear
LM	æraf (7)	15	The truth of Quran and the fake nature of other gods	Digressive (listing-parallel-spiral)
LM	ænbia (21)	5	The truth of Quran, Messengers, Hereafter, and the consequences of belying it	Linear
LM	Zoxrof (43)	6	The truth of Quran, Messengers, Hereafter, and the consequences of belying it	Linear
SM	Hejr (15)	3	The truth of Quran and the punishments of beliers	Linear (parallel)
SM	Shoura (42)	4	The truth of <i>Vahy</i> and the consequences of belying it	Linear (parallel)
SM	Zhariat (51)	2	Devine Promises and the annihilation of cruelers	Linear
SM	Næjm (53)	2	The emphasis on the truth of <i>Vahy</i>	Linear
SM	Qædr (97)	1	The revelation of Quran	Linear
SM	Fælæq (113)	1	To take refuge with Allah	Linear
SM	Leil (92)	1	The distinction between the obedient/disobedient	Parallel
SM	Yasin (36)	3	The consequences of belying Quran and Messengers	Linear
SM	Haaqæ (69)	2	The truth of Hereafter and Quran's promises	Linear (parallel)
SM	Ensheqaq (84)	1	The Day of Judgment and the Repayment process	Parallel
SM	Shæms (91)	1	The creature of the world and Human-being	Linear
SM	Nas (114)	1	To take refuge with Allah	Linear
SM	Exlas (112)	1	The oneness of Allah	Linear
SM	Kothar (108)	1	Allah's blessing and the necessity of being thankful to Him	Linear

The discussions related to the above-presented table are provided in the following section.

### 3.2. Discussions

The discussions of this study are carried out based on the distinction between Quran's Chapters (Makki and Madani) and the four categories identified in this study as follows:

As the above-presented table indicates, the most common rhetorical profile patterning according to which Quran's Chapters are constructed is Linearity. As Chesterman (1988) believes, the main characteristic of this profile is the unity and homogeneity that the elements of the text conserve. As evident in the table above, almost all Makki Chapters (%85) are constructed and elaborated in a linear fashion. Makki Chapters, according to Marefat (1999), mostly elaborate on the clarification of Islamic Beliefs, the Principles of Islam, the rejection of *Sherk*, and the belief in holy divine Messengers and the phenomenon of the Day of Judgment. Therefore, the linear (%85) nature of Makki Chapters (M) is

explainable by the fact that since Allah stated the foundation of Islam and Beliefs in these Chapters, he constructed them with strong unity in subject, in order to be out of any dubiety and skepticism. The other profile patterning found in Makki Chapter is Parallelism (%15). Investigating the content of Makki Chapters, we reached the conclusion that those chapters that elaborate on Islamic Principles such as the truth of *Touhid* (the oneness of Allah), *Vahy*, Quran, Messengers, and the Hereafter follow the Linearity pattern, while those that distinguish believers/unbelievers or the obedient/disobedient follow the Parallelism pattern. For example, in Exlas Chapter (112), comprising of four verses, Quran speaks about the oneness of Allah (verse 1), His absolute independence (verse 2), He begetteth not, nor is He begotten (verse 3), and there is none like unto Him (verse 4). As we can see in the content of this holy Verse, all of the four verses address the oneness of Allah. This is what Chesterman (1988) calls it the unity of content of the linear text. Leil Chapter (92), on the other hand, follows the parallel pattern. As Chesterman (1998, p.172) believes in the pattern of parallelism, the texts “proceeds in a series of balanced pairs of predications, for instance reflecting contrasts or different facets of a single theme”. In Leil Chapter, for example, we can see the track of these kinds of balanced pairs of predictions and contrasts in which Allah juxtaposes different people of opposite sides elaborating on the consequences of what they do. For example, parallel profiles tracked in this holy chapter are as follows:

- Those who spend/not spent the poor (5-8)
- Those who confirms/belies the reward of the deeds (6-9)
- Those who will be roasted in the flaming Fire/ will be far away from it (14-17)

Madani Chapters (MD), on the other hand, follows the same equal rate of profile patterning of Linearity (%50) and Listing (%50). The decrease in the rate of Linearity in Madani Chapters, in comparison to Makki ones, can be explained by the fact that since Madani Chapters are not that concerned of Islamic Principles but of social rules and laws, Allah made also use of Listing profile in these Chapters. In Listing profile, according to Chesterman (1988), all of the predications which are coordinated are subordinated to a single predication. As mentioned above, in Nur Chapter, Allah made use of a complete Listing profile elaborating on the conjugal and private life and how these issues to be observed and respected by others (strangers). Listing profiles found in Nur Chapter are as follows:

- List of the different ways of taking witness before punishing a person accused of fornication (2-9).
- List of how to ask permission for entering others’ houses (27-29).
- The list of commands related to marriage and casting veil (30-33).
- The list of commands related to asking permission for interrupting the conjugal privacy of others (58-61).

In all of the above-mentioned lists of Nur Chapters, we see that all of them are subordinated to a single theme i.e. the laws of conjugal/private life.

#### 4. Conclusion

The answer to the research questions along with the final remarks of this study are provided in this section.

As far as the *research question 1* is concerned, this study shows that we can probe different rhetorical profile patterning in Quran based on Chesterman’s (1988) model. Each of the holy Quran Chapters follows a specific pattern according to which the content organization of that chapter is arranged, although some other profiles may accompany the dominant one (*research question 2*). As far as the most common profile patterning in Quran as a whole is concerned (*research question 3*), this study shows and conclude that Quran’s Chapters mostly follow the Linearity (%81) followed by Listing (%12) and Parallelism (%7). Therefore, according to the correlation existing between the content of Quran Chapters and the rhetorical profile patterning of them, we conclude that the unity of content and the homogeneity of organization is the most concern of Quran followed by making the list of Allah’s commandments and the comparison between those who obey or disobey Allah’s laws and the consequences of what they do.

#### References

- Chesterman, A. (1998). *Contrastive functional analysis*. John Benjamin Publishing Company: AMESTERDAM, PHILADELPHIA.
- Clyne, M. 1987. Cultural differences in the organization of academic texts: English and German. *Journal of pragmatics*. 11(2).211-241.
- Kachru.Y.(1988).*writing in Hindi and English*. In Purves (ed.), 109-137.
- Kaplan. R. B. (2000). Contrastive rhetorics and discourse analysis: who writes what to whom?when? In what circumstances? In S. Sarangi & M. Soultard (Eds.) *Discourse and social life*. Edinburgh: Pearson Education (Longman), pp.82-101.
- Ostler, S. E. (1987). "English in parallels: a comparison of English and Arabic prose". In Connor and Kaplan (Eds.).169-185.
- Marefat, M.H. (1999). *Al-Tamhid fi Olum-el-Quran*. Qom: Jame-aye Modarresin Publication.
- Monroy, R. (2008). Linearity in language: Rhetorical discursive Preferences in English and Spanish in the Light of Kaplan's Model. *International journal of English studies*. 8 (2).173-189.

## A Cross-Cultural Move Analysis of Master and Doctoral Theses/Dissertations Acknowledgment across Gender: the Case of Applied Linguistics Discipline

**Ali M. Fazilatfar**

Associate Professor of Applied Linguistics, English Dept. Yazd University, Yazd, Iran.

**Hossein Kargar Behbahani**

MA Student in TEFL, Yazd University, Yazd, Iran.

**Mina Hosseini**

MA Student in TEFL, Yazd University, Yazd, Iran.

### Abstract

In recent decades, scholars in Applied Linguistics have shown more interest in dissertation acknowledgements in different settings. The present study is based on analyses of the acknowledgements accompanying 90 Masters and PhD dissertations in the field of Applied Linguistics written by students at Iran and UK universities. The aim was to see if there is a significant difference between Iranians and non-Iranians Applied Linguistics post-graduate students in their acknowledgment writing style across gender. The model applied in the current study was Hyland's (2004) model. After analyzing each text, the main moves were extracted and the frequency of each one was calculated and compared. Then, two Chi-square for Group Independence statistical technique were administered to find out the significance of the differences. The results indicated that neither was there any significant difference between Iranian MA and PhD holders across gender nor was there any statistically significant difference between Iranians and non-Iranians PhD holders. In addition, no violation was found according to the applied model. All the examined acknowledgments contained the obligatory thanking move, but only some of them included the optional announcing and reflecting moves. The findings not only confirm the applied model, but also demonstrate that minor cross-cultural variations can be at work in producing the same genre.

**Keywords:** "Dissertations", "Acknowledgments", "Applied Linguistics", "Gender"; "Move Analysis"

### 1. Introduction

Inarguably writing a book or thesis is not an effortless task. Everyone trying to write a dissertation or a book needs support on the part of many individuals to fulfill the at-hand-project. Thus, acknowledgment is truly one of the most inspiring parts of every written book, thesis, dissertation, or whatsoever. Furthermore, acknowledgments are the parts of the academic papers where authors express their appreciation to people who have supported them intellectually and morally during their study. Anyway, it is worth mentioning that there is no one-size-fits-all form for writing this section. Every writer may have his/her own style in writing. Again, each culture may have its own, too. On top of everything, acknowledgments signify not only a unique rhetorical act for interpersonal relationship, but also a reflection of writers' personal identity and socio-cultural and contextual values. Compared with other sections such as the introduction, literature review, methods, results, discussion, and conclusion in dissertations, acknowledgments has received much less attention (Cheng, 2012). One reason for this neglect is perhaps the perception that dissertation acknowledgement section, unlike any of the main component sections of the dissertation, does not form an instrumental construction to the dissertation's rhetorical epistemology and stands outside the research record of establishing academic issues due to the assumption that acknowledgements along with prefaces, illustrations and dedications belong to the para-text category (Al-Ali, 2010).

Acknowledgment may be written by the writer when the project is finished, but it will be first read by the examiners (Paltridge & Starfield, 2007). As Finn (2005, p.118) argues, "first impression last" in the examination process. Therefore, well-written acknowledgments can affect the examiners' judgments.

Accordingly, as Hyland (2004) (cited in Abdollahian & Hashemi; 2013) argues, this section is significant in enabling authors build a credible scholarly and social character in readers' mind. Despite the importance of acknowledgment section, Applied Linguistics has seen few studies done in this regard. The analysis of the genre and its components (say, move structure, thanking pattern, and thanking order), has not been that much cared about. As mentioned, only few studies have been performed in this regard in recent years (i.e. Hyland, 2003, 2004; Gesuato, 2004; Al-Ali, 2010; Mohammadi, 2013; Abdollahian, & Hashemi, 2013). Mohammadi, (2013), and Abdollahian and Hashemi, (2013) studied the acknowledgment section within Iranian context, but none of them looked at this section cross-culturally across gender. Accordingly, further research need to be done to shed more light on the effect of gender on authors' writing style in Iranian and non-Iranian contexts.

According to Hyland (2004) the importance of acknowledgements is highlighted by the results of surveys and the frequency with which they occur in scholarly texts. They are part of the academic practice of reciprocal gift giving in the same way as citations often are, and for this reason are particularly important to research students. Acknowledgements in theses and dissertations allow students to demonstrate their awareness of some central academic values such as modesty and gratitude, establish their credibility, recognize debts, and achieve a sense of closure at the end of what is often a long and demanding research process.

The choice language is very crucial to maintain social relationships (Buyukkantarcioglu, 1998). The same holds true for thanking expressions which form the heart of acknowledgments. According to Abdollahian, and Hashemi, (2013), with an inappropriate use of language, thanking which at first meant to be a face-enhancing act can turn into a face-threatening act when contextual (e.g., cultural environment) and/or personal factors (e.g. degree of intimacy) are disregarded. But, thanking can engender feelings of warmth among interlocutors when performed appropriately (Eisenstein & Bodman, 1993). The primary purpose of this study is to examine the cross-cultural similarities and differences between the genre texts in Iranian and non-Iranian contexts across authors' gender.

The present contrastive analysis arose from our interest in determining the component moves that form the basic elements of acknowledgment section in master and doctoral dissertations in both Iranian and non-Iranian contexts. The researchers hope that the results will contribute to a better understanding of the similarities, differences, and preferences of Iranian and non-Iranian TEFL and Applied Linguistics & TESL MA and PhD holders across gender in writing acknowledgment section of their MA theses or PhD dissertations.

## 2. Review of Literature

Acknowledgments are short pieces of writing through which the writer seeks to explicitly negotiate interpersonal relationships and reflect socio-cultural interactions that have received little attention in the literature, most significantly those written in Persian. The importance of this section actually derives from their high frequency of appearing in books, articles, and most notably MA and PhD dissertations. This section demarcates a combination of institutional, academic, financial, technical, interpersonal, and moral support to the person or institutions for their contributions (Mohammadi, 2013). Thus, Al-Ali (2004) comes to the stage and argues, as PhD students are prospective members of the academic community, they are expected to demonstrate awareness not only of reciprocal gift giving rules that they should apply in areas of civilized life but also of central values and rules as well as the community oriented ethos that should apply in this regulated activity of academic practice (p.36).

Acknowledgments are, as Brodkey (1987) states, formal properties of scholarly texts and are part of the cultural repertoire of all academics. The history of this section, which sometimes appear in the preface

and sometimes appear as an isolated section itself, according to Giannoni (2002), goes back to when the writers were dependent on the powerful ones in authority so as to publish their academic works. Bazerman (1984), in his experimental reports in physics notes that acknowledgements date back to 1890s; they were personal testimonials to friends and mentors while those that re-emerged in the 1920s were more spare, sharing limited forms of credit, and recognizing institutional dependencies. Nonetheless, he further argues that acknowledgments did not explicitly emerge until 1940 and were not a regular feature of Physical review articles until 1960.

As cited in Al-Ali (2010), for Swales & Feak (1994:203) the acknowledgment section is not only a display of gratitude for assistance, but also an opportunity for acknowledgers to show that they are members of the academic community and have benefited from that membership. Hyland (2000) points out that by acknowledging the debt of precedent, a writer is able to show the fidelity to a particular community and establish a credible writer ethos. Moreover, Benn-Ari (1987) defines the acknowledgment as special contextual construct whose formation is governed by conventions which are different from those of the main text. Furthermore, he sees this section as

Formulations that take on an intermediate position between the internal contents of the ethnography and the people and relationships outside it: they are both an introduction to an intellectual product and a reconstruction of the external contributions that have gone towards its realization (p.65).

The literature on the acknowledgment section, as pointed out earlier, is very limited despite the fact that the section is a very common part of dissertations (i.e., 80% of MA theses and 98% of PhD dissertations in Hyland & Tse (2004). Unfortunately, very few studies have been conducted to examine acknowledgments written by MA and PhD students. The literature mainly comprises the studies done by Hyland (2003, 2004) and Hyland & Tse (2004), which aimed at exploring the structure of the acknowledgments and the pattern of thanking expressions appearing in acknowledgments based on a corpus of 240 MA theses and PhD dissertations written by non-native English speakers in six academic fields (i.e. Applied Linguistics, Biology, Business Studies, Computer Sciences, Electronic Engineering and Public Administration). Moreover, to the best of my knowledge, only Mohammadi, (2013) and Abdollahian and Hashemi (2013) have examined acknowledgment section within an Iranian context, but none of them looked at this section cross-culturally across gender. So, further research need to be conducted to examine the impact of gender in the study of rhetorical moves in writing the acknowledgment section among Iranians and non-Iranians.

As quoted in Abdollahian and Hashemi, (2013), Hyland (2013) concentrates on the textualization of the gratitude suggesting that acknowledgments reflect authors' unique rhetorical choices which are shaped by the authors' social and cultural characteristics and by the field they get specialized in. Hyland (2004) generates a content-based framework for acknowledgments by introducing three separate moves: **reflecting move**, the section where the authors comment on their experiences; **thanking move**, the place presenting gratitude to academic assistance, family and friends; and **announcing move**, the final part including the acceptance of responsibilities for flaws or errors and dedication of the thesis. It is also worth mentioning that, in their work, Hyland (2004) made it crystal clear that one of the moves, the thanking one (move 2) is obligatory, whereas other moves, namely reflecting move (move 1), and announcing move (move 3), are optional. For them, in thanking move there are 4 sub-divided steps, namely presenting participants (Step 2.1), thanking for academic assistance (Step 2.2), thanking for resources (Step 2.3), and thanking for moral support (Step 2.4). Also, there are two sub-divided steps for the third move, namely accepting responsibility (Step 3.1) and dedicating the thesis (Step 3.2).

The above three studies (Hyland, 2003; 2004; Hyland & Tse 2004) set the scene and opened the window for subsequent research. Zhao & Jiang (2010) examined DA written by Chinese speakers in China using a

corpus from English-related disciplines, and found that the structure generally follows Hyland's (2004) model. Nevertheless, subtle differences were seen. In their corpus, the first two moves are absent, specially Step 3.2, and the writers were prone to excessively use the bare mention form and modifiers in the thanking act. Within an Islamic context, Al-Ali (2010) works on a corpus of 100 acknowledgments written by Arabic native speakers in English within the framework of the move structure proposed by Hyland (2004), the Reflecting- Thanking- Announcing Move structure. He faces the "Thanking Allah" pattern in the Arabic PhD dissertations as one additional move. Examining the acknowledgments, he builds a new move structure (see Table 1) for the Arabic acknowledgments, observes the thanking strategies employed in the moves and makes a socio-cultural analysis of the PhD dissertation acknowledgments written by the native speakers of Arabic.

Table1. *Number of Move components in Dissertations Acknowledgments written in Arabic Source: Al-Ali, 2010:8*

Component Moves of Arabic acknowledgments n:100	Number of Moves
1.Opening	25
2.Praising and Thanking Allah (God)	70
3.Thanking Supervisors and other Academics	100
4.Acknowledging Access to Resources	62
5.Thanking for Moral Support	61
6.Invoking and Blessing	68
7.Closing	52
8.Signing off	20

Genre analysis has become a crucial approach to text analysis. According to Swales (1990), a genre comprises a class of communicative events, the members of which share some set of communicative purposes. These purposes are recognized by the expert members of the parent discourse community, and thereby constitute the rationale for the genre. This rationale shapes the schematic structure of the discourse and influences and constrains choice of content and style. Communicative purpose is both a privileged criterion and one that operates to keep the scope of a genre as here conceived narrowly focused on comparable rhetorical action. In addition to purpose, exemplars of a genre exhibit various patterns of similarity in terms of structure, style, content and intended audience.

According to Bhatia (1993) cross-cultural variation in spoken interaction has become a well-established area of discourse study but very little has been published in the case of written genres, though recently there have been some indications of interest in cross-cultural variation in academic and professional discourse. It has been well known for some time that various cultures organize and develop ideas differently when writing expository texts and these differences persist when users of these languages and cultures learn to write in a new language. In a recent study, Hinds (1990: 98), investigating expository writing in Japanese, Korean, Chinese, and Thai, discovered that in all these languages there is a common style which is characterized by 'delayed introduction of purpose'. This delayed introduction of purpose, he claims, has the undesirable effect of making the essay appear incoherent to the English-speaking



reader, although the style does not have this effect on the native speaker. Others (Hinds, 1990; Clyne, 1981; Kaplan, 1983; Connor & McCagg, 1983; Cheng, 1985) have also come up with similar findings in the case of expository and argumentative prose. However, the situation is somewhat less than satisfactory in the area of professional and academic genres.

### Research Questions

1. Is there any significant difference in frequency of Moves Iranian TEFL MA and PhD holders adopt in writing their dissertations acknowledgment across gender?
2. Is there any significant difference in frequency of Moves Iranian TEFL PhD and non-Iranian Applied Linguistics & TESL PhD holders adopt in writing their dissertations acknowledgment across gender?

### Hypotheses

The above research questions will lead into the following null hypotheses:

1. There is no significant difference in frequency of Moves Iranian TEFL MA and PhD holders adopt in their dissertations acknowledgment across gender.
2. There is no significant difference in frequency of Moves Iranian TEFL PhD and non-Iranian Applied Linguistics & TESL PhD holders adopt in their dissertations acknowledgment across gender.

### 3. Methodology

#### 3.1 Corpus

The dissertations analyzed in the present study were 90 dissertations in the field of applied linguistics which were all randomly downloaded. They were collected from different universities of Iran and Great Britain. In current study we have 30 Iranian MA theses in TEFL (15 males, 15 females), 30 Iranian PhD dissertations in TEFL (15 males, 15 females), and 30 non-Iranian PhD dissertations in Applied Linguistics & TESL (15 males, 15 females). All of the items selected were written in English. Along the same lines, to control the rapid changes in style of writing, the dissertations were all selected from the past twenty years. In order to see the tables of frequency, please look below.

Table 2. *Frequency of MA in TEFL whose authors are Iranian male*

University	Frequency
Yazd	7
Ilam	1
Ferdowsi	1
Urmia	1
Sistan and Baluchestan	2
Tarbiat Modares	1
Zanjan	1
Semnan	1

Table 3. *Frequency of MA in TEFL whose authors are Iranian female*

University	Frequency
Ilam	3
Zanjan	2
Sistan and Baluchestan	1

Urmia	2
Tarbiat Modares	1
Ferdowsi	1
Tabriz	1
Shahid Chamran	1
Yazd	3

Table 4. Frequency of PhD in TEFL whose authors are Iranian male

University	Frequency
Tabriz	2
Shiraz	4
Isfahan	6
Allameh Tabataba'i	3

Table 5. Frequency of PhD in TEFL whose authors are Iranian female

University	Frequency
Tehran	6
Allameh Tabataba'i	5
Shiraz	1
Tabriz	1
Isfahan	2

Table 6. Frequency of PhD in Applied Linguistics &amp; TESL whose authors are non-Iranian male

University	Frequency
University of London Institute of Education	2
University College London(UCL)	1
Durham University	1
University of Manchester	1
University of Huddersfield	1
University of Southampton	4
University of Leeds	1
University of Warwick	4

Table 7. Frequency of PhD in Applied Linguistics &amp; TESL whose authors are non-Iranian female

University	Frequency
University of Sheffield	2
University of Leeds	3
University of Birmingham	5
Durham University	2
University of York	1
University of Warwick	2

### 3.2. Theoretical Framework:

Within this context, according to Hyland, all acknowledgment parts include 3 moves mentioned above, namely Reflecting Move, Thanking Move, and Announcing Move. According to him, other moves, such as Thanking Allah's move in Al-Ali's model, are deemed to be optional while writing a thesis acknowledgment section. Thus, in order to see whether our sample fit into Hyland's model some statistical techniques were used which are to be discussed below.

## 4. Data Analysis and Results

At first the relevant tables for each research question will be presented and then each of the two research questions will be addressed by the researchers.

4.1. Addressing Research Question No. 1

In this research question because all the variables are categorical each having two or more values, the use of Chi-square for Group Independence is warranted (Rezai, 2015).

Table8. Case Processing Summary

	Cases					
	Valid		Missing		Total	
	N	Percent	N	Percent	N	Percent
gender * move	74	100.0%	0	0.0%	74	100.0%
degree * move	74	100.0%	0	0.0%	74	100.0%

Gender\*Move  
Table9. Interaction

		Move			Total
		Announcing	Thanking	Reflecting	
Gender	Count	3	30	4	37
	Expected Count	1.5	30.0	5.5	37.0
	male % within gender	8.1%	81.1%	10.8%	100.0%
	% within move	100.0%	50.0%	36.4%	50.0%
	% of Total	4.1%	40.5%	5.4%	50.0%
	Count	0	30	7	37
	Expected Count	1.5	30.0	5.5	37.0
	female % within gender	0.0%	81.1%	18.9%	100.0%
	% within move	0.0%	50.0%	63.6%	50.0%
% of Total	0.0%	40.5%	9.5%	50.0%	
Total	Count	3	60	11	74
	Expected Count	3.0	60.0	11.0	74.0
	% within gender	4.1%	81.1%	14.9%	100.0%

% within move	100.0%	100.0%	100.0%	100.0%
% of Total	4.1%	81.1%	14.9%	100.0%

Table10. Chi-Square Tests

	Value	Df	Asymp. Sig. (2-sided)
Pearson Chi-Square	3.818 <sup>a</sup>	2	.148
Likelihood Ratio	4.988	2	.083
Linear-by-Linear Association	2.704	1	.100
N of Valid Cases	74		

a. 2 cells (33.3%) have expected count less than 5. The minimum expected count is 1.50.

Degree\*Move

Table 11. Interaction

		Move			Total
		Announcing	Thanking	Reflecting	
Degree	Count	0	30	3	33
	Expected Count	1.3	26.8	4.9	33.0
	MA % within degree	0.0%	90.9%	9.1%	100.0%
	% within move	0.0%	50.0%	27.3%	44.6%
	% of Total	0.0%	40.5%	4.1%	44.6%
	Count	3	30	8	41
	Expected Count	1.7	33.2	6.1	41.0
	PhD % within degree	7.3%	73.2%	19.5%	100.0%
	% within move	100.0%	50.0%	72.7%	55.4%
% of Total	4.1%	40.5%	10.8%	55.4%	
Total	Count	3	60	11	74
	Expected Count	3.0	60.0	11.0	74.0
	% within degree	4.1%	81.1%	14.9%	100.0%

% within move	100.0%	100.0%	100.0%	100.0%
% of Total	4.1%	81.1%	14.9%	100.0%

Table12. Chi-Square Tests

	Value	Df	Asymp. Sig. (2-sided)
Pearson Chi-Square	4.460 <sup>a</sup>	2	.108
Likelihood Ratio	5.651	2	.059
Linear-by-Linear Association	.098	1	.754
N of Valid Cases	74		

a. 3 cells (50.0%) have expected count less than 5. The minimum expected count is 1.34.

Because all the variables in the first research question were categorical each having at least 2 values, namely gender (male, and female), degree (MA, and PhD), a Chi-square for Group Independence was conducted to see if there is any difference between those Iranians holding MA and PhD in TEFL across gender. The results, as illustrated in Table 10, shows that considering the interaction of gender and moves, no statistically significant difference can be found between males and females at 2 degrees of freedom because the alpha value exceeds 0.05. Regarding the interaction between degree and move, as table 12 indicates, there is, again, no statistically significant difference between Iranian MA and PhD holders at 2 degrees of freedom because here, too, the alpha value exceeds that of 0.05. So, we can conclude that there is no significant difference between Iranian TEFL MA and PhD holders in the frequency of moves they adopt while writing their master or doctoral dissertations across gender. Having done the above mentioned statistical techniques, the first null hypothesis claiming that there is no statistically significant difference between Iranian TEFL MA and PhD holders in their frequency of moves is confirmed.

4.2. Addressing the 2<sup>nd</sup> research question

Table 13. Case Processing Summary

	Cases					
	Valid		Missing		Total	
	N	Percent	N	Percent	N	Percent
gender * Moves	80	100.0%	0	0.0%	80	100.0%
nationality * Moves	80	100.0%	0	0.0%	80	100.0%

Gender\*Move

Table 14. Interaction

		Moves			Total
		Announcing	Thanking	Reflecting	
gender	Count	4	30	4	38
	Expected Count	2.9	28.5	6.7	38.0
	male % within gender	10.5%	78.9%	10.5%	100.0%
	% within Moves	66.7%	50.0%	28.6%	47.5%
	% of Total	5.0%	37.5%	5.0%	47.5%
	Count	2	30	10	42
	Expected Count	3.2	31.5	7.4	42.0
	female % within gender	4.8%	71.4%	23.8%	100.0%
	% within Moves	33.3%	50.0%	71.4%	52.5%
	% of Total	2.5%	37.5%	12.5%	52.5%
Total	Count	6	60	14	80
	Expected Count	6.0	60.0	14.0	80.0
	% within gender	7.5%	75.0%	17.5%	100.0%
	% within Moves	100.0%	100.0%	100.0%	100.0%
	% of Total	7.5%	75.0%	17.5%	100.0%

Table 15. Chi-Square Tests

	Value	Df	Asymp. Sig. (2-sided)
Pearson Chi-Square	3.046 <sup>a</sup>	2	.218
Likelihood Ratio	3.136	2	.208
Linear-by-Linear Association	2.978	1	.084
N of Valid Cases	80		

a. 2 cells (33.3%) have expected count less than 5. The minimum expected count is 2.85.

Nationality\*Moves

Table16. Interaction

		Moves			Total	
		Announcing	Thanking	Reflecting		
nationality	Count	3	30	8	41	
	Expected Count	3.1	30.8	7.2	41.0	
	Iranian	% within nationality	7.3%	73.2%	19.5%	100.0%
	% within Moves	50.0%	50.0%	57.1%	51.2%	
	% of Total	3.8%	37.5%	10.0%	51.2%	
	Count	3	30	6	39	
	Expected Count	2.9	29.3	6.8	39.0	
	non-Iranian	% within nationality	7.7%	76.9%	15.4%	100.0%
	% within Moves	50.0%	50.0%	42.9%	48.8%	
	% of Total	3.8%	37.5%	7.5%	48.8%	
	Count	6	60	14	80	
	Expected Count	6.0	60.0	14.0	80.0	
Total	% within nationality	7.5%	75.0%	17.5%	100.0%	
% within Moves	100.0%	100.0%	100.0%	100.0%		
% of Total	7.5%	75.0%	17.5%	100.0%		

Table 17. Chi-Square Tests

	Value	Df	Asymp. Sig. (2-sided)
Pearson Chi-Square	.236 <sup>a</sup>	2	.889
Likelihood Ratio	.237	2	.888
Linear-by-Linear Association	.167	1	.683
N of Valid Cases	80		

a. 2 cells (33.3%) have expected count less than 5. The minimum expected count is 2.93.

Because all the variables of the second research questions were categorical each having 2 values namely, gender (male and female) and nationality (Iranian and non-Iranian) a Chi-square for Group Independence was performed to find out whether there is any significant difference between Iranian TEFL PhD and non-Iranian Applied Linguistics & TESL PhD holders across gender. Regarding the interaction between gender and move, the obtained results, as shown in Table 15, demonstrate no statistically significant difference between Iranian TEFL PhD and non-Iranian Applied Linguistics & TESL PhD holders in the moves they adopt while writing their dissertation acknowledgment section ( $p=.218$ ,  $df=2$ ). Besides, so as to find out whether there is an interaction between nationality and frequency of moves in acknowledgment section, as table 17 demarcates so neatly, there is again no statistically significant difference between Iranians PhD and non-Iranian PhD holders in the field of Applied Linguistics ( $p=.889$ ,  $df=2$ ). All in all, the above tables show that the second null hypothesis claiming that there is no statistically significant difference between Iranians TEFL PhD and non-Iranians Applied Linguistics & TESL PhD holders in their frequency of moves is verified.

## 5. Discussion

In above section, the results of Chi-square for group Independence were presented and it was revealed that, based on Hyland's (2004) model, there is no statistically significant difference between Iranian MA and PhD holders in TEFL across gender, nor is there any difference between those Iranians holding PhD in TEFL and those non-Iranians holding PhD in Applied Linguistics & TESL across gender.

Based on Hyland's (2004) assertion, there is only one obligatory move in acknowledgment section. This study was conducted to see whether Iranian TEFL and non-Iranian Applied Linguistics & TESL post-graduate students trying to write their master these or doctoral dissertations are aware of such moves and adopt them in their acknowledgment writing or violated such kind of model.

The only obligatory move, according to Hyland, is thanking move. Every other move found in acknowledgment is optional. In a study conducted by Al-Ali (2010), it was found that Arabs in their acknowledgment writing use one further move which is Thanking Allah. Hyland believes that every other move in addition to the thanking move is optional. Further, Hyland (2004) believe that in thanking move there are 4 sub-divided steps, namely presenting participants (Step 2.1), thanking for academic assistance (Step 2.2), thanking for resources (Step 2.3), and thanking for moral support (Step 2.4), thus this Thanking Allah pattern found in Al-Ali's (2010) study cannot be obligatory. Notwithstanding, this pattern was also found in almost half of Iranian MA dissertations. Example of which is: I want to express my thanks to God who constantly gave me wisdom and courage and who never put me in temptation that this journey would be unsuccessful. Because these optional moves or steps were not the focus of the



study, to make a long story short, I find no clue discussing them in more detail. As discussed above, the focus of this study was the frequency of moves between Iranians and non-Iranians. Hyland (2004) believe that the Announcing Move is one optional move which along with Reflecting Move might or might not be used in an acknowledgment section. Let us discuss each one of the three moves in turn below.

### 5.1. Move 1: Reflecting Move

According to Hyland (2004, 311) this move is peripheral to the main purpose of the genre. It allows students to publicly contemplate the understandings they have gained as a result of the research experience; it often recalls the struggles involved or the sense of accomplishment achieved, and no step are described to perform these goals. This kind of move is more frequent in Spanish acknowledgments than in the English ones and its position is also different: it is always initial in the Spanish sequences but occupies the medial position (M2s) in English in two of the three cases.

### 5.2. Move 2: Thanking Move

This move involves 4 steps.

The first step is presenting participants: I would like to express my gratitude to the participants of my study, many of whom are students of mine. My M.A. thesis would have never been completed without their participation.

The second step is thanking for academic assistance. The third one is thanking for resources and the last one is thanking for moral support. It is worth mentioning that among all the dissertations scrutinized in this study, this second move was found in them all.

### 5.3. Move 3: Announcing Move

Accepting responsibility for the flaws and dedicating the thesis are two steps of this move. Both Spanish and American writers dedicate their theses to family (parents, brothers, sisters, grandmothers, etc.). Spanish writers dedicate it also to girlfriends and friends that supported the writer during hard times, and show a great commitment with society (cited in Maruenda-Bataller & Clavel-Arroitia, 2011).

In the analysis of the data, the length of the acknowledgments written by eastern researchers were more than their western counterparts especially in thanking their friends and their family. This means that Acknowledgements gave these students the opportunity to express what they considered to be significant influences on the processes of completing their research.

The Announcing Move in Hyland (2004) classification, includes two steps; the first step refers to taking responsibility of all the errors and flaws encountered in their dissertations and the second one is dedicating their work to someone else.

As for the Announcing Move, the Iranian writers may not want to add the dedication in their acknowledgments because they have already written the names to whom they dedicate their theses in the dedication section. Therefore, writing dedication in acknowledgments in non-Iranian theses was higher than Iranian one. In addition, no difference was found among the non-Iranian and Iranian researchers in taking the responsibility of errors in their acknowledgments because only a few of them tended to accept their flaws.

## 6. Conclusion

The main purpose behind doing this research was to find out whether there is any statistically significant difference between Iranian TEFL MA and PhD holders and Iranians and non-Iranians PhD holders in Applied Linguistics both across gender. To achieve this goal, a total of 90 dissertations were randomly selected (30 MA theses by Iranians, 30 PhD dissertations by Iranians, and 30 PhD dissertations by non-Iranians). It is worth mentioning that each 30 dissertations were divided into two groups of 15 (15 males and 15 females). After conducting the relevant statistical techniques which were two Chi-square for Group Independence, it was revealed that neither is there any statistically significant difference between Iranian MA and PhD holders across gender, nor is there any significant difference between those acknowledgments section written by Iranians and non-Iranians PhD holders in the field of Applied Linguistics across gender

The findings of the current study not only verify the generic structure of thesis/ dissertation acknowledgments described by Hyland (2004) but also show that minor cross-cultural variations can be at work in producing the same genre. Bhatia (1997) also confirms that genre analysis provides novice writers with useful information about the conventions of a particular genre to enable them produce more complex texts. With the awareness of genre practices, novice writers can gain long-term benefits from the explicit knowledge of genre conventions to ultimately produce more complex genres based on genre exemplars (Loi & Evans, 2010).

This paper examined how Persian L1 speakers and non-Iranians adopt the three moves proposed by Hyland (2004). However, much work remains to be done to find the boundaries between personal rhetorical choices available to writers, the options related to socio-cultural constraints, the ideas borrowed from other theses and those due to the general academic conventions that transcend socio-cultural allegiance. No doubt qualitative research through personal interviews with the writers of the acknowledgment writers is needed to tease out their consciousness of their rhetorical choices in the process of production of these texts. Such kind of research can also be extended to other disciplines to understand whether there is any difference between Iranians and non-Iranians writers in different fields of study. Moreover, authors' age, seniority, and previous publishing experience can also be examined.

## References

Abdollahian, G & Hashemi, M (2013). A Contrastive Study of Generic Organization of Doctoral Dissertation Acknowledgments by Iranian Students across Humanities sub-disciplines. *International Journal of Language Learning and Applied Linguistics World (IJLLALW)*, (4) 582-600.

Al-Ali, M (2004). How to get yourself on the door of a job: A cross-cultural contrastive study of Arabic and English job application letters. *Journal of Multilingual and Multicultural Development*, 25, 1-23.

Al-Ali, M (2010). Generic Patterns and Socio-cultural Resources in Acknowledgments Accompanying Arabic Ph.D. Dissertations. *Pragmatics* 20:1, 1-26.

Bazerman, C (1987). Codifying the social scientific style: The APA manual as a behaviorist rhetoric. In John S. Nelson, Anne Megill, & Donal N. McCloskey (Eds.). *The rhetoric of the human sciences: Language and argument in scholarship and public affairs*. Madison: University of Wisconsin Press.

Benn-Ari, E. (1987). On acknowledgments in ethnographies. *Journal of Anthropological Research*, 43 (1), 63-84.

Bhatia, V. (1993). *Analyzing Genre: Language Use in Professional Settings*. London: Longman.

Bhatia, V. (1997). Genre-mixing in academic introductions. *English for Specific Purposes*, 16(3), 181-195

- Brodkey, L. (1987). *Academic Writing as Social Practice*: Philadelphia: Temple University Press.
- Buyukkantarcioglu, N. (1998). Presenting selves through language: A social psychological approach to discourse analysis. *Hacettepe Universitesi, Edebiyat Facultesi Dergisi*, 15(2), 157-162.
- Cheng, W. (2012). A contrastive study of master thesis acknowledgments by Taiwanese and North American students. *Open Journal of Modern Linguistics*, 2(1), 8-17.
- Clyne, M. (1981). Cultural differences in the organization of academic texts. *Journal of Pragmatics* 11, 211-247.
- Connor, U, & P. McCagg (1983). Cross-cultural Differences and Perceived in Written Paraphrases of English Expository Prose. *Applied Linguistics*, 4(3), 259-268.
- Finn, J. (2005). *Getting a PhD: An action plan to help manage your research, your supervisor and your project*. London: Routledge.
- Giannoni, D. (2002). Worlds of gratitude: A contrastive study of acknowledgment texts in English and Italian research articles. *Applied Linguistics*, 23, 1-31.
- Hinds, J. (1990). Inductive, deductive, quasi-inductive: Expository writing in Japanese, Korean, Chinese and Thai. In U. Connor, and A.M. Johns (eds). *Cohesion in Writing-Research and Pedagogical Perspectives*. TESOL 97-109.
- Hyland, K. (2000). *Disciplinary Discourses: Social Interactions in Academic Writing*. London: Pearson.
- Hyland, K. (2003). Dissertation acknowledgments: The anatomy of a Cinderella genre. *Written Communication*, 20, 242-268.
- Hyland, K. (2004). Graduate's gratitude: The generic structure of dissertation acknowledgments. *English for Specific Purposes*, 23, 303-324.
- Hyland, K. & Tse, P. (2004). "I would like to thank my supervisor": Acknowledgments in graduate dissertations. *Applied Linguistics*, 14, 259-275.
- Kaplan, R. (Ed). (1983). *Annual review of applied linguistics, 1982*. Rowley, MA: Newbury House. King-ek, A., Artetxe, S. Astigarraga, M., Beloki, E., Gaminde, I., Goenaga, X., Ibero, I., Ithussary.
- Loi, C. & Evans, M. (2010). Cultural differences in the organization of research article introductions from the field of educational psychology: English and Chinese. *Journal of Pragmatics*, 42(10), 2814-2825
- Maruena-Bataller, S. & Clavel-Arroitia, B. (2011). *Multiple Voices in Academic and Professional Discourse: Current Issues in Specialised Language Research, Teaching and New Technologies*. Cambridge Scholars Publishing.
- Mohammadi, M. (2013). Do English and Persian dissertation acknowledgments accommodate Hyland's model: A cross-linguistic study. *International Journal of Academic Research in Business and Social Sciences*, 3 (5), 534-547.
- Paltridge, B. & Starfield, S. (2007). *Thesis and dissertation writing in a second language: a handbook for supervisors*. Routledge.
- Rezai, M. (2015). *ABC of SPSS for Students of Applied Linguistics*. Yazd University Press.

Swales, J. (1990). *Genre analysis: English in academic and research settings*. Cambridge: Cambridge University Press.

Swales, J. & Feak, C. (1994). *Academic Writing for Graduate Students: Essential Tasks and Skills*. An Arbor: University of Michigan Press.

Zhao, M., Jiang, Y. (2010). Dissertation acknowledgment: Generic Structure and Linguistic features. *Chinese Journal of Applied Linguistics*, 33(1): 94-109.

WILEY

## The Motivational Outcomes Of Connectivism Theory In EFL

Mohammad Borna (corresponding author)<sup>1</sup>, Mahboobeh Fouladchang<sup>2</sup>

<sup>1</sup> Department of Educational psychology, Shiraz University, Shiraz, Iran

<sup>2</sup> Department of Educational psychology, Shiraz University, Shiraz, Iran

### Abstract

The purpose of this study was to examine the effect of connectivism instructional method in comparison with communicative language teaching method on academic self-efficacy and task value among students in EFL. The current study was a 2 (instructional methods)\*2 (genders) factorial design with pre-post-test. Statistical population included all high school students in grade 3 from Ramhormoz city in Iran. Participants included students in four classes that were selected by available sampling method and then completed the motivational beliefs subscale of MSLQ (1991). The results showed the connectivism instructional method was significantly more effective than communicative language teaching method. Based on the results of this research, it is concluded that connectivism instructional method provide unique opportunities for increasing the self-efficacy and task value of students by increasing social intractions and diversity for choosing tasks. Accordingly, this research suggests the application of connectivism instructional method in order to increase academic self-efficacy and task value in EFL classrooms for the students.

Keywords: connectivism theory, communicative language teaching, self-efficacy, task value

### Introduction

The ultimate goal of educational approaches in each of the areas of learning, including English teaching as a foreign language, is facilitating the learning processes in learners. However, education in its best form should not only lead to learning in learners but also need to activate learning-related potentials (Hargreaves, 2004). Accordingly, there can be some motivational outcomes such as academic self-efficacy and task value as important learning outcomes related to learning (Pintrich & DeGroot, 1990). Academic self-efficacy was first introduced in social cognitive theory by A. Bandura's (1986). Self-efficacy is defined as personal judgments of one's capabilities to organize and execute actions to attain designed goals (Bandura, 1997; 2006). Also, academic self-efficacy specifically refers to student's beliefs about their ability to successfully complete academic assignments (Bandura, 1986). D.H. Schunk (1991) offered a similar definition for academic self-efficacy, which refers to student's beliefs about their ability to perform academic tasks at designated levels and ultimately leads to desirable and significant outcomes associated with learning. The direct relationship of the self-efficacy to learning has been reported in various studies (e.g. Bandura, 1993; Neuville, Frenay, & Bourgeois, 2007; Palos et al, 2011; Yazici, Seyis, & Fatma, 2012; Kim, & Park, 2015; Papa, 2015; Alqurashi, 2016; Gbollie, & Keamu, 2017). For instance E. Alkurashi (2016) in a research aimed at examining the role of academic self-efficacy in online learning environments concluded that a high academic self-efficacy in learners leads to their better use of online learning environments.

Moreover A. Wigfield and J.S. Eccles (2000) in their social cognitive model of expectancy-value paid attention to another component called task value. According to P.R. Pintrich and E.V. DeGroot (1990), task value is one of the main components associated with motivational beliefs. Task value refers to the students' perception of the interest, importance, and usefulness of the materials and the learning content at classrooms (Pintrich, Smith, Garcia, & McKeachie, 1993). Also, task value refers to student's perceptions of the interest, usefulness, importance, and cost of a task. Attention to task value has led to desirable and significant outcomes associated with learning (Eccles & Wigfield, 2000), and the direct relationship of it with learning has been reported in various studies (e.g. Pintrich, & DeGroot 1990; Zimmerman & Pons, 1990; Bong, 2001; Hemin Khezri et al, 2014; Al-Harethi & Aldhafri, 2014; Lawanto et

al, 2014). For instance, P.R. Pintrich and E.V. DeGroot (1990) pointed to the positive role of task value in relation to academic achievement.

According to social cognitive theorists such as B. Zimmerman (2000), J.B. Smart (2014), L. Linnebrinck-Garcia, E.A. Patel, and R. Packan (2016), the quality of education, teaching strategies and the teacher's teaching style have central roles in order to enhance the motivational outcomes including academic self-efficacy and task value. Educational systems always seek ways to provide the desirable motivational outcomes for learners, in order to engage them in formal and informal activities related to education and learning (Lester, 2013). Also, M. Borna (2012), G.H.R Golmohammadnejad Bahrami (2015), J. Sánchez-Rosas and S. Esquivel (2016) have pointed to the role of educational approaches as one of the most important factors influencing motivational outcomes. Finally, B. Prince (2017) and K. Kultawanicha, P. Koraneekija, and J. Na-Songkhlaa (2014) believe that one of the main consequences of effective education is to create positive motivational outcomes such as academic self-efficacy and task value in learners. Therefore, in their view one of the most important feature in identifying or distinguishing desirable approaches from undesirable ones is the motivational outcomes of these approaches. Educational approaches in the field of teaching EFL due to their comprehensiveness in their theoretical frameworks (such as the role of teacher, the role of student, the content of learning) claim to focus on other variables in addition to learning. In fact, first these approaches are trying to have a desirable impact on learning. Then they seek to extend this impact to other variables related to education and learning such as academic self-efficacy and task value. Accordingly, considering the importance of motivational outcomes the present research tries to examine the effectiveness of connectivism-based approach on self-efficacy and task value in comparison to CLT among high school students.

The communicative language teaching approach or CLT was raised in the second half of the 20th century in the field of teaching and learning the second language. This approach was first introduced in the late 1960s when linguist Noam Chomsky developed a theory that led to the notion of the term communicative competence (Savignon, 1991; 2007). Second, According to J.C. Richards and J.T. Rodgers (1986, p.64), the CLT could date back to the changes in the British language teaching tradition originating from the late 1960s. At that time, applied linguists in Britain began to call into question the theoretical assumptions underlying situational language teaching and seeks to strengthen the language skills of the learners by paying attention to community competence (Savignon, 2007; Muhammad, 2016; Tan, 2016; Kibbe, 2017). CLT is a cover term for a number of approaches that developed in the 1970s in critical reaction to audio-lingual teaching methods and their unsatisfactory results. They all criticize the mechanistic nature of audio-lingual pattern drills which fail to prepare learners for a productive use of the target language in the many different communicative situations of everyday life. The common goal of communicative approaches is communicative competence (Power, 2003). Also the CLT approach highlights learners' communicative competence (Hymes, 1972), which is defined as learners' ability to efficiently express what they mean in the target language and successfully achieve communications in real-life situations (Lightbown and Spada, 1999; Power, 2003; Richards, 2006). CLT seeks to strengthen communicative competence. However, this approach has come with some problems that caused this method turn out not to be so much successful and the learning outcome not to be efficient enough. These include student's lack of motivational outcomes for developing communicative competence, low English proficiency and resistance to class participation, incompatibility of CLT teaching method with university entrance exam, lacking CLT a clear cut assessment procedure, incompatibility of CLT with EFL home culture and values, not having sufficient teacher training courses to promote teachers awareness, challenges related to creating the right kind of interaction for teachers, little time for developing materials for communicative classes, and large classes. In addition, there is an important problem that causes the method turn out not to be so much successful- this method does not involve using digital or virtual space in order to teaching of EFL (Koosha, & Yakhabi, 2013; Maryslessor, Barasa, & Omulando, 2014; Heidaryasl, 2015). Therefore,

given the above considerations, it is necessary to pay attention to new educational approaches in order to overcome the challenges of teaching and learning of EFL.

Connectivism is a new theory of learning that has been proposed by George Siemens and Stephen Downes in recent years following the changes in the digital era (Siemens, 2005; Downes, 2008; 2012). The connectivism theory has been developed for global village with insisting on distributing knowledge and experience and consequently changing the concept of learning (Bell, 2011; Barnett, McPherson, & Sandieson, 2013; Ozan, 2013; Ibrahim & Ibrahim, 2017). Stated simply, connectivism is social learning that is networked (Duke, Harper, & Johnston, 2013). G. Siemens (2005; 2012) coined the term connectivism, to describe learning networks. Connectivism is the thesis that knowledge is distributed across a network of connections, and therefore that learning consists of the ability to construct and traverse those networks. An account of connectivism is therefore necessarily preceded by an account of networks (Downes, 2012). This theory claims to have made new developments through the attention to the effects of the advent of the digital era, in the field of education and learning in general and teaching and learning of EFL in particular. For instance, K. vesela (2013) believes that the application of the principles of connectivism theory in teaching EFL includes focusing on the categories that are rarely found in the common approaches of teaching EFL such as the CLT approach. Categories such as concurrent attention to the diversity of opinions, English learning is a process of creating connections among the nodes or information resources, English teaching may reside in human and non-human appliances, in order to English learning currency (daily use and operation) and accuracy is the aim of connectivist activities, also the role of supportive and facilitator of the teacher among the most important components that are considered in the teaching of English using connectivism theory. These components have not been considered in the CLT approach.

There is little research on the effect of connectivism-based education on the motivational outcomes such as self-efficacy and task value. However, few studies examined the relationship between connectivism theory and motivational outcomes in the recent years. For example, K. Kultawanicha, P. Koraneekija, and J. Na-Songkhlaa (2015) believe that the connectivism theory has the potential strength to increase learner's motivational outcomes in association with learning experiences. Also U. Noytim (2010) believe that the use of web-based technologies in the process of training will increase the motivational outcomes. Ultimately, G.H.R. Golmohammadnezhad Bahrami (2015) believes that the use of web-based technologies in education and learning through increasing of social interaction, updating learners and an active effort to acquire new knowledge will lead to improving of academic self-efficacy, task value and the amount of learning. Therefore according to the specialists, approaches based on connectivism theory is likely to have a better ability to increase motivational outcomes in the present era.

Based on the above considerations, the question arises whether the connectivism theory can be increased the self-efficacy and task value through the integrated attention to the features such as knowledge management by students, up-to-date and attention to lifelong learning, interaction and attention to the role of digital media? As previously mentioned, U. Noytim (2010), G.H.R. Golmohammadnazhad Bahrami (2015), and Zimmerman, & Kulikowich (2016) showed that interaction and establishing social relationships through access to new spaces, also the role of digital media as a challenging opportunity in teaching the present era; it has led to a significant increase in academic self-efficacy and task value, interest and confidence in learners. So finally it can be concluded that the use of the connectivism theory could be possibly led to promoting of self-efficacy and task value. Also due to what has been said about the factors influencing the motivational outcomes; the supporting and facilitator role of the teacher, the management of the learning process by the learners, and active learning through formation of peer groups and relationships are among the factors of creating positive motivational outcomes such as academic self-efficacy and task value in learners (Kultawanicha, Koraneekija, & Na-Songkhlaa, 2015; Prince, 2017). Hence, the attention to the above features seems to be among the key principles of

connectivism. So that, G. Siemens (2005; 2012) believes learning is available knowledge management that occurs through the formation of real or virtual human networks. Finally, it seems that when students acquire the necessary opportunity to acquire the required knowledge and then formulate the concept based on their interests and backgrounds, they will experience as much improving in motivational outcomes as such as self-efficacy and task value. Therefore, the connectives theory of learning should most likely have the capacity to help learners to create desirable motivational outcomes in comparison with CLT, and it is expected that the use of connectives theory in current study will improve the motivational outcomes for learners in comparison to CLT.

Another problem that has been addressed in this study is gender role as a moderating variable. The principle of diversity is emphasized as one of the main features of the connectivism approach. As G. Siemense (2005) and S. Downes (2012) believe that diversity in the identification of nodes and networks and how to connect them has a fundamental importance in learning. Also, according to G. Siemens (2005), available knowledge, the principle of decision making, and the interaction of learners in the digital environment is emphasized in education through the connectivism approach. In fact, according to G. Siemens (2005) and Downes (2012), it can be expected that the type of interactions that learners create in the connectivism approach will lead to different gender preferences. As these different gender preferences ultimately lead to different motivational outcomes in learners. For example, the principle of diversity can be found in lexical preferences associated with gender or communication content among learners. Therefore, considering the above characteristics the question arises as to whether the effectiveness of connectivism-based approach is significantly different about motivational beliefs between males and females? The present research is important because it firstly addresses one of the most important problems in Iran's educational system. Education of Iran every year costs millions of dollars for teaching English. But the result of this investment is the cost of graduating graduates who ultimately do not achieve language competences in accordance with R.L. Oxford's (2003) definition of EFL and the efforts made in this area largely fail.

### Research hypotheses

- 1- The effect of connectives-based approach on the motivational beliefs is more than the communicative language teaching approach in EFL.
- 2- There is a difference between males and females in terms of the effectiveness of the connectives-based approach on motivational beliefs in EFL.

### Research methodology

This research is a quasi-experimental design using pre-test and post-test. The statistical population of this study included all male and female students of the third grade high schools from Ramhormoz city in Iran, who were studying in 2016-2017. Participants were students in four classes who were selected by available sampling. Then each of the classes was assigned to one of the two groups using the random division. After administration of pre-test, the training packages related to independent variable levels were performed over a period of 9 sessions of 90 minutes. Finally, to investigate the possible effects of educational approaches a post-test on academic self-efficacy and task value of English language was implemented.

The instrument used in the present study was Motivated Strategies for Learning Questionnaire (MSLQ) that prepared by P.R. Pintrich et al (1991). In this study, academic self-efficacy subscale including 8 items and task value subscale including 6 items were used. The participant's responses scored using a 5-point Likert type scale, from 1(not at all true of me) to 5 (very true of me). In the academic self-efficacy subscale, students respond to questions such as «I'm sure I can have good performance in language lessons and exams». Also in the task value subscale, students respond to questions such as «It's very important for me



to learn the content of this lesson». All questions are graded directly in self-efficacy and task value subscales. The reliability of this scale was reported using Cronbach's alpha for academic self-efficacy ( $r=0.93$ ) and task value ( $r=0.90$ ) by P.R. Pintrich et al (1991). Also, they used a factor analysis to evaluate the construct validity, which resulted in the scales confirmed in this questionnaire. In the present study, for the purpose of reliability analysis, Cronbach's alpha was used. The coefficients for academic self-efficacy and task value were 0.92 and 0.87, respectively, which are reliable coefficients. Also in order to study the construct validity of the motivational beliefs questionnaire a confirmatory factor analysis was used. For this purpose, the main components analysis method was used. The KMO coefficient was 0.823, which indicates the adequacy of the sample for performing factor analysis. The value of Bartlett's sphericity test was 648.676 and also significant at  $P<0.0001$ . Then, according to the value of the specific that was above one, and also the charts and using the irregular rotation method, the varimax method was two subscales, which explained 65.52% of the total variance of the scores. All of the items, according to P.R. Pintrich et al (1991), were related to their own.

In the connectivism-based training group the use of knowledge management in nodes, human resources and inhumanity, the identification and use of networks related to the learning unit, the use of real and virtual networking and the formation of groups was emphasized. Also, in the CLT group the use of the target language, communicating through short dialogues and creating two or more interactions in the classroom was emphasized. For instance, in table1 a brief description of the first session of each of the experimental groups is presented.

Table 1. A brief description of the first session with topic «Where are you from? »

First session	content
CLT	A new lesson begins by broadcasting dialogues related to the title of the lesson through the bar. Then those dialogues are run by the teacher. After that the learners will run two or more multi-player dialogues. Finally teachers learn the important points of dialogue through teacher guidance.
Connectivism-based approach	Pre-class learners collected words related to the new lesson using the information of available human and inhuman nodes and networks such as sites, real and virtual dictionaries, virtual language learning groups, language partners and virtual networks related to English language training. Accordingly, the teacher asked the groups to introduce the world's 20 countries. Also, sort these countries based on geographic diversity and the continents. Then the students will introduce the capital of those countries and will provide some information about the population of those countries.

**Results**

In the present study, the effect of educational approaches including connectivism and CLT on academic self-efficacy and task value was studied in male and female students. First, descriptive statistics including mean and standard deviation of the pre-test and post-test scores for dependent variables are presented in table 2.

Table 2. Mean and standard deviation of academic self-efficacy and task value in male and female students

Variable	test	CLT group				Connectivism group			
		N=40		N= 40		N= 40		N= 40	
		Mean		Standard deviation		Mean		Standard deviation	
		Male	female	male	female	Male	female	male	female
Academic self-efficacy	Pre-test	25.55	26.30	8.630	6.309	26.55	31.55	8.449	6.874
	Post-test	28.65	27.25	4.655	5.234	32.65	36.00	3.277	6.365
Task value	Pre-test	20.30	20.65	4.694	5.904	18.80	24.80	4.938	4.851
	Post-test	24.05	22.25	3.316	2.381	27.40	28.452	2.963	1.905

The results of table 2 show that the mean scores of students in connectivism and CLT groups are very different in the post-test. For example, the post-test scores of females in academic self-efficacy are 27.25 and 36.00 for connectivism and CLT groups, respectively. Also the standard deviation of male's post-test scores in academic self-efficacy is 5.234 and 6.365 for connectivism and CLT groups, respectively.

The necessary assumptions for multivariate covariance analysis were considered. For example, the dependent variables followed a normal distribution for each group. Because based on the Shapiro-Wilk test, none of the dependent variables are significant at any level of the independent variable. Also, to ensure the assumptions of homogeneity of variance/covariance matrices and homogeneity of variance between groups were checked through the Box's M and Levine's tests, respectively. Meaninglessness of these two was considered as prescriptive observation (BOX' M =15.885, F=1.681, P=088). Ensuring the assumptions allows the use of multivariate covariance analysis method. Accordingly, the multivariate tests are presented in tables 3.

Table 3. Multivariate tests for self-efficacy and task value in educational approaches

Effect	tests	value	F	sig	PES
Pre-test	Wilks'	.692	16.480	.000	.308
	Lambda				
Group	Wilks'	.504	36.418	.000	.496
	Lambda				
sex	Wilks'	.964	1.392	.255	.036
	Lambda				
Sex*group	Wilks'	.957	1.664	.196	.043
	Lambda				

Based on the results of table 3, Wilks' Lambda test showed that the effect of educational approaches on academic self-efficacy and task value was significant ( $F = 36.14, P < 0.001$ ). So that, considering the effect of pre-test, about 50% of the variance of motivational beliefs was due to teaching methods. Since, the results of multivariate tests was significant, a separate assessment of each of the dependent variables can be made. Thus, in table 4 the results of univariate tests are presented, to examine the effect of the independent variables on each of the dependent variables.

Table 4. Tests of between subject effects for investigating of effect of educational approaches on self-efficacy and task value in male and female students

Source	Dependent Variable	SS	df	MS	F	sig	PES
Corrected Model	Self-efficacy	1425.164	4	356.291	18.735	.001	.500
	Task value	600.334	4	150.083	24.928	.001	.571
Group	Self-efficacy	579.827	1	579.827	30.489	.001	.289
	Task value	368.176	1	368.176	61.152	.001	.449
Sex	Self-efficacy	1.588	1	1.588	.071	.790	.001
	Task value	16.775	1	16.775	2.786	.099	.036
Sex*group	Self-efficacy	30.193	1	30.193	1.588	.212	.021
	Task value	15.890	1	15.890	2.639	.108	.034
Error	Self-efficacy	1426.323	75				
	Task value	451.554	75				

The results of table 4 showed that the implementation of teaching methods has a significant effect on academic self-efficacy and task value. So that, after adjusting the pre-test, about 29% of the variance of academic self-efficacy and about 45% of the variance of task value is related to applying teaching methods. Also, according to table 4, the effect of gender variable and its interaction with groups on academic self-efficacy and task value in EFL has not been meaningful. Now that the results of table 4 indicated the significant impact of the implementation of educational approaches on motivational beliefs, one can answer the question of which educational approach has a more effect on academic self-efficacy and task value? In order to answer the above question, table 4 presents a pairwise comparison of the effects of the experimental groups.

Table 3. Pairwise Comparison for self-efficacy and task value in CLT and connectivism groups

Dependent Variable	group	group	ME	SE	sig
Self-efficacy	connectivism	CLT	5.474	.991	.000
Task value	connectivism	CLT	4.362	.558	.000

The results of table 5 showed that the male and female students in connectivism group was more successful than CLT group in terms of the effect on self-efficacy and task value ( $P < 0.001$ ). This means that the null hypothesis is based on the insignificance of the difference is rejected, and the hypothesis that the students in the education group based on connectivism theory had a more effective performance than the students of the CLT group, were acceptable at a satisfactory level of significance.

### Discussion and conclusion

The purpose of this study was to examine the effect of connectivism instructional method in comparison with CLT on the academic self-efficacy and task value of EFL among male and female students. The results of the testing the first hypothesis showed that the experimental group which was trained using connectivism approach showed the more scores in the post-test of academic self-efficacy and task value compared to CLT approach. Therefore, the first hypothesis of the study is confirmed. The recent finding is in accordance with other findings (Noytim 2010; Golmohammadnzhad Bahrami, 2015; Kultawanicha, Koraneekija, & Na-Songkhlaa, 2015). For example, the results of K. Kultawanicha, P. Koraneekija, and J. Na-Songkhlaa (2015) showed that the use of connectivism theory in education and learning process will lead to increased motivational beliefs. In explaining the above result, different points can be made. U. Noytim (2010), G.H. Golmohammadnzhad Bahrami (2015), and W.A. Zimmerman, and J.M. Kulikowich (2016) believe that interaction and establishing social relationships through access to new spaces; also, the role of digital media as a challenging opportunity in teaching the present era, it has led to a significant increase in the motivational outcomes associated with learning such as academic self-efficacy and task value, interest and confidence in learners.

The explanation for this finding is that the students in the approach based on connectivism theory have opportunities to increase motivational beliefs through diversity and attention to the individual's interest in choosing content or tasks, constructive interaction with human and in human resources, managing all or Part of the learning and knowledge available, and up-to-date through access to digital space (Siemens, 2005). Also, the factors influencing the motivational outcomes, the supporting and facilitating role of the teacher, the management of learning processes by learners and the creation of active learning through the formation of peer groups and relationships are among the factors that create positive motivational outcomes such as academic self-efficacy and task value in learners (Kultawanicha, Koraneekija, & Na-Songkhlaa, 2015; Prince, 2017). Hence, the attention to the above features seems to be among the key principles of connectivism, As Siemens believes; learning is available knowledge management that occurs through the formation of real or virtual human networks (Siemens, 2005). Therefore, the connectivism theory has been able to demonstrate more impact on academic self-efficacy and task value than the CLT. In this regard, G. Siemens (2005) and K. Veselá (2013) believe that one of the key features of connectivism theory is to pay attention to the above principles. They believe learners are dynamic and active in connectivism educational approach unlike current approaches, and the main task of interacting, identifying nodes, networks, human resources and inhumanities associated with the learning unit, as well as identifying and creating new connections is learners' responsibility. As, this issue ultimately leads to increased self-esteem, academic self-efficacy, interest and task value in learners. Also, the teacher acts as facilitator in the connectivism approach, and learners play a more active role in the learning process in

compared with CLT. For instance, students actively find the words related to new learning unit through nodes, networks and available resources, and share them for other students through digital or real environments. In fact, to accomplish such a goal, students need to know the nodes, networks and connections associated with English language learning and teaching units, besides that ultimately, themselves should be able to make new connections in this area. The item that is rarely found in the commonly used CLT.

The results of the research in order to study the second hypothesis showed that student's gender was not an effective factor in creating a significant difference between the post-test scores of English language motivational beliefs using education based on connectives theory. In other words, in the present study, the effectiveness of connectives approach on self-efficacy and task value was as same as about male and female students, and there was no significant difference between male and female post-test scores on education through this approach. However, it was expected that there was a significant difference in the effectiveness of the connectives approach on males and females. Because, according to (Kultawanicha, Koraneekija, & Na-Songkhlaa, 2015; Linnenbrink et al, 2016; Prince, 2017) how interacting with individuals, teachers, content, and digital space, as well as the quality of digital education, are two important factors in increasing academic self-efficacy and task value. G. Siemens (2005) and S. Downs (2012), also argue that in connectivism theory; attention to the diversity of beliefs and opinions in identifying nodes, networks, resources, available knowledge management, and how to establish connections, interactions and new connections, especially through digital space are considered. Accordingly, the present study was expected that diversity and how to interact with the human as well as inhuman, nodes, resources and networks, such as the use of multimedia and digital media, will be influenced by gender, and the learner's gender can play a role in interacting with the concept of linking learning. As it was observed, the hypothesis in the present study was not confirmed. It seems that one of the factors influencing non-approval of the second hypothesis, the lack of familiarity of some learners with nodes and information resources such as multimedia education, sites, social networks, digital space and, consequently, the lack of enough skills in new interacting, connecting and communicating through the space mentioned. So that the provided trainings in the short time interval in the present study have not been able to show the interactive effect of the type of education and gender of students.

Also, the prevailing atmosphere of education and learning English language at previous and current classes is designed to challenge education through active approaches such as education based on connectivism theory. So that, both boys and girls are equally benefited in this training. Finally, some legal restrictions imposed by the educational system of Iran on the use of digital space, such as the challenge of having or not having a mobile phone at school, or preventing the entry of learners into social networks by filtering some social networks along with other unknown factors are among the factors that challenges the impact of gender in interacting with education through connectivism in this short period of time. Therefore, the researcher has been confronted with limitations in measuring gender differences due to the factors mentioned above. It is necessary in future researches, by providing adequate time and Follow up research, opportunities will be provided for the use of digital environment by learners in the field of education and learning English language ensure more certainty.

Based on the findings of this study, it is desirable Education will work towards using approaches that lead to higher motivational outcomes and, ultimately, learner's learning, and in this regard, the approach based on connectivism theory has a special priority in comparison with CLT approach. In fact, the use of a connectivism-based approach considering the human and inhuman interactions, digital space and multimedia education will ultimately lead to academic self-efficacy and higher level task value as well as academic achievement in EFL.

This study was conducted in English classes, it is suggested that in future researches, the effectiveness of a connectivism-based approach to other lessons such as sociology, empirical sciences, life skills should be considered. In fact, connectivism theory seems to have a positive impact on the motivational beliefs of the lessons mentioned.

## References

- Al-Harthy, I. S., & Aldhafri, S. S. (2014). The relationship among task-Value, self-efficacy and academic achievement in Omani students at Sultan Qaboos University. *International Review of Social Sciences and Humanities*, 7 (2), 15-22.
- Alqurashi, E. (2016). Self-Efficacy in online learning environments: A literature review. *Contemporary Issues in Education Research*, 9(1), 45-52.
- Bandura, A. (1986). *Social foundations of thought and action: A social cognitive theory*. Englewood Cliffs, NJ: Prentice- Hall.
- Bandura, A. (1993). Perceived self-efficacy in cognitive development and functioning. *Educational Psychologist*, 28, 117-148.
- Bandura, A. (2006). Adolescent development from an agentic perspective. In F. Pajares, & T. Urdan (Eds.), *Self-efficacy beliefs of adolescents* (pp. 1-43). Greenwich, CT: Information Age Publishing.
- Barnett, J., McPherson, V., & Sandieson, R. M. (2013). Connected teaching and learning: The uses and implications of connectivism in an online class. *Australasian Journal of Educational Technology*, 29(5), 685-698.
- Bell, F. (2011). Connectivism: Its Place in Theory-Informed Research and Innovation in Technology - Enabled Learning. *International Review of Research in Open and Distance Learning*, 12(3), 98-118.
- Bong M. (2001). Between and within Domain Relations of Academic Motivation among Middle and High School Students: Self- Efficacy, Task value and Achievement Goals. *Journal of Educational Psychology*, 9(93), 23-34.
- Borna, M. (2013). Comparison of Effectiveness of mastery learning approach, community language teaching and combined method on English learning rate, English language instrumental motivation and academic self-efficacy in guidance third grade students in Saveh city. M.A" Thesis.
- Downes, S. (2012). *Connectivism and Connective Knowledge; Essays on meaning and learning networks*. ISBN: 978-1-105-77846-9; Version 1.0 – May 19, 2012. This work is published under a Creative Commons License, Attribution-NonCommercial-ShareAlike CC BY-NC-SA.View Legal Code: <http://creativecommons.org/licenses/by-nc>
- Downes, S. (2008). Places to go: Connectivism & connective knowledge. *Innovate: Journal of Online Education*, 5(1). <http://nsuworks.nova.edu/innovate/vol5/iss1/6>
- Duke, B., Harper, G., & Johnston, M. (2013). Connectivism as a digital age learning theory. *The International HETL Review. Special Issue 2013* (pp. 4-13)
- Gbollie, c., & Keamu, H. P. (2017). Student Academic Performance: The Role of Motivation, Strategies, and Perceived Factors Hindering Liberian Junior and Senior High School Students Learning. *Education Research International*. <https://doi.org/10.1155/2017/1789084>
- Goldie, J. G. S. (2017). Connectivism: a knowledge learning theory for the digital age? *Medical Teacher*, 38(10), 1064-1069.
- Golmommadnazhad bahrami. Gh. R. (2015). Role of using internet on self-Efficacy, educational Motivation and educational achievement; Tabriz University of medical sciences. *Bimonthly of Education Strategies in Medical Sciences*, 8(4), 255-260
- Hargreaves, D. H. (2004). *Learning for Life: the Foundations for Lifelong Learning*. Bristol: Policy Press.
- Hemin Khezri, A., Lavasani, M. G., Malahmadi, E., & Amani, J. (2010). The role of self- efficacy, task value, and achievement goals in predicting learning approaches and mathematics achievement. *Procedia Social and Behavioral Sciences*, 5, 942-947.

- Heydari Asl, E. (2015). Comparative study of grammar translation method (GTM) and communicative language teaching (CLT) in language teaching methodology. *Enternational Journals of Science and Research Methodology*, 1(3), 16-25.
- Hymes, D. H. (1972). "On communicative competence" In J. B. Pride and J. Holmes Sociolinguistics. Selected Readings. Harmondsworth, 269-293. (Part 1).
- Ibrahim, M. K., & Ibrahim, Y. A. (2017). Communicative English language teaching in Egypt: Classroom practice and challenges *Issues in Educational Research*, 27(2), 285-311.
- Kibbe, T. (2017). The history of communicative language teaching (CLT) and its use in the classroom. *United States Military Academy during Academic Year 2017*. <https://www.usma.edu/cfe/Literature/Kibbe>
- Kim, J., & Park, M. (2015). E-learning satisfaction by self-efficacy in higher education. *International Journal of Software Engineering and Its Applications*, 9(10), 109-116.
- Koosha, M., & Yakhabi, M. (2013). Problems associated with the use of communicative language teaching in EFL contexts and possible solutions. *International Journal of Foreign Language Teaching and Research*, 1(2), 63-76.
- Kultawanicha, K., Koraneekija, P., & Na-Songkhlaa, J. (2015). A Proposed Model of Connectivism Learning Using Cloud-based Virtual Classroom to Enhance Information Literacy and Information Literacy Self-efficacy for Undergraduate Students. *Social and Behavioral Sciences* 191, 87 – 92.
- Lawanto, O., Santoso, H. B., Goodridge, W., & Lawanto, K. N. (2014). Task Value, Self-Regulated Learning, and Performance in a Web-Intensive Undergraduate Engineering Course: How Are They Related? *Journal of Online Learning and Teaching*, 10 (1), 97-111.
- Lester, D. (2013). A Review of the Student Engagement Literature. *Focus On Colleges, Universities, and Schools*, 7(1), 1-8.
- Linnenbrink-Garcia, L., Patall, E. A., & Pekrun, R. (2016). Adaptive motivation and emotion in education: Research and principles for instructional design. *Policy Insights from the Behavioral and Brain Sciences*, 3(2), 228-236. <http://dx.doi.org/10.1177/2372732216644450>
- Lightbown, P., & Spada, N. (1999). *How Languages are Learned*. New York: Oxford University Press. Second Edition.
- Maryslessor, A. O., Barasa, P. L., & Omulando, C. A. (2014). Challenges teachers face in the use of the communicative language teaching approach in the teaching listening and speaking lessons in Lugari District, Kenya. *International Journal of Science and Research*, 3(9), 83-92.
- Muhammad, Z. (2016). Pakistani government secondary schools students' attitudes towards Communicative language teaching and grammar translation in Quetta, Balochistan. *Published by Canadian Center of Science and Education English Language Teaching*, 9(3), 258-270.
- Neuville, S., Frenay, M., & Bourgeois, E. (2007). Task value, self-efficacy and Goal orientations: Impact of self-regulated learning, choice and performance among university students. *Psychological Belgica*, 47(1), 95-117.
- Noytim, U. (2010). Weblogs enhancing EFL students' English language learning, *Procedia Social and Behavioral Sciences*, 2 (2010), 1127-1132.
- Oxford, R. L. (1990). *Language learning strategies: What every teacher should know*. Boston: Heinle & Heinle.
- Oxford, R. L. (2003). Language learning styles and strategies: an overview. *Learning Styles & Strategies/Oxford, GALA*, 1-25.
- Ozan, O. (2013). Scaffolding in connectivist mobile learning environment: *Distance Education-TOJDE*, 14(2).
- Palos, R., Munteanu, A., Costea, I., & Macinga, I. (2011). Motivational and cognitive variables with impact on academic Performance Preliminary study. *Procedia Social and Behavioral Sciences*, 15. 138-142.
- Papa, L. A. (2015). *The Impact of Academic and Teaching Self-Efficacy on Student Engagement and Academic Outcomes*. All Graduate Theses and Dissertations. <https://digitalcommons.usu.edu/etd/4361>
- Pintrich, P. R., & DeGroot, E. V. (1990). Motivational and self-regulated learning components of classroom academic performance. *Journal of Educational Psychology*, 82, 33-40.

- Pintrich, P. R., Smith, D. A., Garcia, T., & McKeachie, W. J. (1991). A manual for the use of the Motivated Strategies for Learning Questionnaire (MSLQ). National Center for Research to Improve Postsecondary Teaching and Learning. Ann Arbor: University of Michigan.
- Prince, B. (2017). Improving the self-efficacy of math learners using a direct and focused Approach to vocabulary clarification. A Project Submitted to the School of Graduate Studies of the University of Lethbridge in Partial Fulfillment of the Requirements for the Degree master of education.
- Power, T. (2003). Communicative Language Teaching: The appeal and poverty of Communicative Language Teaching. *TESOL Quarterly*, 25 (7), 87-96. Retrieved November 1, 2004, from <http://www.btinternet.com/~ted.power/esl0404.html>
- Richards, J. C. (2006). *Communicative Language Teaching Today*. Cambridge University Press.
- Richards J. C., & Rodgers, T. S. (2003). *Approaches and methods in language teaching, 2nd Edition*, Cambridge: Cambridge University Press.
- Sánchez-Rosas, J. & Esquivel, S. (2016). Instructional Teaching Quality, Task Value, Self-Efficacy, and Boredom: A Model of Attention in Class. *Revista de Psicología*, 25(2), 1-20. <http://dx.doi.org/10.5354/0719-0581.2017.44966>
- Savignon, S. J. (1991). Communicative language teaching state of the art. *TESOL Quarterly*, 25, 261-275. <http://dx.doi.org/10.2307/3587463>
- Savignon, S. J. (2007). Beyond communicative language teaching: What's ahead? *Journal of Pragmatics*, 39(1), 207-220.
- Schunk, D. H. (1991). Self-efficacy and academic motivation. *Educational Psychologist*, 26, 207-231.
- Siemens, G. (2005). Connectivism: A learning theory for a digital age. *International Journal of Instructional Technology and Distance Learning*, 2(1), 1-8.
- Siemens, G. (2012). MOOCs are really a platform [Web log post]. Retrieved from <http://www.elearnspace.org/blog/2012/07/25/moocs-are-really-a-platform>
- Smart, J. B. (2014). A mixed methods study of the relationship between student perceptions of teacher-student interactions and motivation in middle level science. *Research in Middle Level Education*, 38(4), 1-19.
- Tan, Z. X. (2016). An empirical study on the effects of grammar-translation method and task-based language teaching on Chinese college students' reading comprehension. *International Journal of Liberal Arts and Social Science*, 4(3), 100-109.
- Veselá, K. (2013). Connectivism in foreign language education. *Education and Languages in Europe / Bildung und Sprachen in Europa*, 25(17), 320-325.
- Wigfield, A., & Eccles, J. S. (2000). Expectancy-value theory of achievement motivation: A developmental perspective. *Educational Psychology*, 25, 68-81.
- Yazici, H., Seyis, S. & Fatma, A. (2012). Emotional intelligence and self-efficacy beliefs as predictors of academic achievement among high school students. *Procedia Social and Behavioral Sciences*, 15, 2319-2323.
- Zepke, N., & Leach, L. (2010). Improving student engagement: Ten proposals for action. *Active Learning in Higher Education*, 11(3), 167-177.
- Zimmerman, W. A., & Kulikowich, J. M. (2016). Online Learning Self-Efficacy in Students With and Without Online Learning Experience. *American Journal of Distance Education*, 30 (3): 180-191.
- Zimmerman B. (2000). Self-Efficacy: An Essential Motive to Learn. *Contemp Educ Psychol*, 25(1), 82-91.
- Zimmerman, B., & Pons, N. (1990). Student Differences In self- Regulated Learning. *Journal of Educational Psychology*, 14(82), 51-59.



## An overlook on musical and semantic repetition in Persian poem

Dr. Asadollah Jafari

Department of Language and Persian Literature, Faculty of Literature and Foreign Language University  
of Payame noor, IR of IRAN

Seyyed Hosein Mostafavi

M.A. student of Persian literature, Payam Noor Univeristy

### Abstract

The musical repetition of poem is very important aesthetically and in fact it is the same rhythm of audible phones, phonemes and words which figures out the different musical kinds of poems such as internal, lateral and external music by proper replacement in speech. Internal music is placed in verbal figures of speech whereas lateral and external music are placed in poetics and rhyme. In semantics repetition, the musical aspect of poem is not investigated and only different aspects of semantics in figures such as simile, allegory, metaphor, symbol, periphrasis are investigated in semantics and pragmatics. This paper attempts to study repetition in both musical and semantic fields in detail.

**Keywords:** poem, music, repetition, verbal, semantic

### Introduction

Poem is a rhythmic and rhymed discourse. Nasir al-Din al-Tusi mentions in Meyarul Ashar: "poem is a rhythmic imaginary discourse in Logic and a rhythmic and rhymed discourse in audience point of view" (Nasir al Din al-Tusi, 1393:21). Repetition is valuable when it has a positive effect on artistic and aesthetic aspect of poem. Shafii Kadkani expresses in Poem Music: "speaking about artistic repetition, I mean the repetition having creative role in poem structure. Although repetition needs obscenity and obscenity negates art, the effect of some kinds are so that it becomes the center of narrator's artistic creativity" (Shafii Kadkani, 1389: 408).

### Repetition in Persian poem

In this paper, various repetition in Persian poem is going to be investigated in repetition music and semantics repetition.

#### Repetition music

Generally music cannot be imagined without repetition and frequency. Repetition is the first important element in constitution of this kind of music. Repetition is a set of vowels, consonants, rhymes, words, sentences and other factors which contains the main part of poem music.

#### Phone repetition

Phoneme repetition consists of repeating a phone, several phones in a syllable, the whole syllable and the sequence of several syllables. Word repetition guarantees a kind of phoneme repetition in any level of being studied. It doesn't mean that all repetitions can be investigated only in phoneme repetition level, because as describing a particular word repetition doesn't fit a phone structure of a syllable, an analysis level has to be considered to contain the range of repetition function. For the same reason some of the word repetitions are necessarily investigated from grammar and vocabulary point of view (Safavi, 1394: 183-184).

#### External alliteration

External phoneme repetition is a kind of alliteration. External repetition or poetic meter is the result of vowels repetition and the sequence of their length. This may cause cohesion in rhythm and then in sentences, couplets and hemistiches.

#### Poetic meter repetitions

Poetic meter repetition is in fact the different syllable repetition. Repetition in poetic meters which causes rhythm may lead to a kind of music repetition. The syllable repetition is going to be investigated in phoneme repetition field.

#### Periodic rhythm repetition

Periodic rhythm is the rhythm of a hemistich consisting of a two halves with rhythmic meter.

#### Internal phoneme repetition

In this part, according to the internal music of poem, internal repetition includes some figures such as pun, expressing the qualifications of someone or something (Tatabe Ezafat), seduction of prepositions (Tansiq Elsefat), etc.

#### Alliteration

It means the repetition of a vowel or consonant in several words of a sentence. It can be carried out through vowel repetition and consonant repetition.

#### Initial alliteration

The repeated phone will be at the beginning, initial alliteration is not possible with consonants.

#### Median alliteration

It means that the repeated phone is in the middle of the words.

#### Final alliteration

It means the repeated phone is at the end of the word.

#### Initial-final alliteration

It means where the repeated phone is at the beginning and end of two consecutive word at the end of the first and at the beginning of the second.

#### Distributed alliteration or accompaniment

One of the most pleasant kinds of alliteration called accompaniment where several phones have close sounds.

#### Vowel alliteration or homophony

It is a kind of alliteration dealing with vowels. Shamsia calls it as homophony (Shamsia, 1393:74).

#### Sound semantic

Some words that their sounds leads the listener to the sound resource. In west, they are considered as words whose sound and accent leads the audience to its resource.

#### Tatabe Ezafat

It is considered as a subset of homophony. Unlike Arabic, it seems to be pleasant in Persian due to the repetition of short vowel "e" (Shamsia, 1393:75).

#### Sayaqat Aladad

Where several singular word are brought after each other in a sentence.

#### Tansiq Elsafat

Where several adjectives and adverbs are mentioned for a noun and verb, respectively.

### Pun (paronomasia)

Pun (Paronomasia) is where words are totally similar in dictation or pronunciation but with different meaning (Esfandyarpor, 1388: 23-24).

Partial pun: where the only difference in short vowel of two words (Shamsia, 1393: 56).

Present pun: as mentioned before, where there is a little difference between initial consonants, i.e. the have close place of articulation (Shamsia, 1393: 56).

### La Haq Pun

The pun words are different in a letter at the beginning or in the middle and they don't have close place of articulation (Esfandyarpor, 1388: 42).

### Matrafpun

In order to avoid of dividing figures, it seems reasonable to call the different in final letter of pun words as present or La Hagh, but as it was called Matraf by the first Perian author such as Saheb Hadaeq Elsehr, it is studied as Matraf Pun in this book.

### EshteghaqPun

Where both words are derivate from a single word. It means they have the same letters but different meaning (Rajaii, 1359:406).

### Shebhe-Eshteghaq pun

Where they have similar pronunciation but different letters (Rajaii, 1359: 406).

### Qalb pun

Where in a poem or prose two word have reverse letters (Esfandyarpor, 1388: 52).

### Zaed pun

Where one word has a letter more than the other and it is in 3 type: Mazid, Mktanefand Mazil (Esfandyarpor, 1388: 36)

In present study, the rhyme is investigated in word repetition and in this section only phone repetition is going to be investigated in rhyme level.

### Lateral repetition

In this paper, lateral repetition is considered as phone repetition in rhyme.

### Bi-rhymed

The poems in which two rhymes are next or close together (Homaii, 1363: 78).

### Tasmit (medium rhyme)

It has three types: a) double b) triple c) quadruple

a)where a hemistich is divided into two parts and both are rhymed.

b)where a couplet is divided into four parts which the first three is rhymed and the last one is the rhyme of couplet.

c)where the couplet is divided into four parts and all four are rhymed (Esfandyarpor, 188: 59-64).

### Tashtir

It means part and section. The couplet is divided into four equal parts in which the two first part have different rhyme with two last parts (Esfandyarpor, 1388: 64).

### Initial rhyme

The rhymes are at the beginning of hemistiches (Vahidian Kamkar, 1393:35).

**Internal rhyme**

There is a rhyme in first and second hemistiches that is not in the middle but they are symmetrical (Vahidian Kamyar, 1393: 35).

**Multi-rhymed**

Where there are more than two rhymes in a couplet. This is also called Mafsal and Maghab and it is close to Tasti'

**Tashri'**

Where there are two rhymes in a couplet and ended up to each rhyme. The meaning is right but another meter is resulted (Esfandyarpor, 1388: 216-217).

**The reverse of rhymes**

Where the couplet has two rhymes. But the rhymes of first hemistiches have different place in second hemistiches. The only condition is that the letter in both rhymes should be the same.

**The repetition of rhymes**

Where each hemistiches of a couplet has different rhymes. In the following, the first hemistiches and second hemistiches have similar rhymes (Esfandyarpor, 1388: 218).

**Enat**

Enat means, in addition to the cooperation of rhymes the cooperation of pervious syllable(s) are obeyed (Shamsia, 1369:113).

**Vocabulary repetition**

These figures are different kinds of Tasdir, Tasbiq, Enat, alliteration, Tard o Aks, Rad Alghafiye, Radif, Hajeb, Ertefa, Ta'taf, total pun, composed pun and sound pun.

**Different kinds of Tasdir**

Where there is a repetition of vocabulary in sentence and are:

- a) Rad Alsadr Ela Alajz
- b) Rad Alajz Ela Alsadr
- c) Rad Alebteda Ela Alajz
- d) Rad Alsadr Ela Alaroz
- e) Rad Alaroz Ela Alebteda
- f) Rad Alaroz Ela Alajz

**Enat**

Where it is needed to bring some words in any hemistich or couplet by poet.

**Aks**

Where the words in rhymes or hemistich are brought reversely in other rhyme or hemistich (Esfandyarpor, 1388: 72-73).

**Total pun**

The pronunciation is the same whereas the meaning is different (Shamsia, 1393: 49).

**Sound pun**

The pun between (محظور/محذور), (فطرت.قترت), (خوار/خار).

**Composed pun**

It is a kind of total pun and has two types:

- a) where two pun words have same pronunciation but different stress.

b)both words are composed which is also called Malfaq.

Rad Alghafiye

Where the rhyme of first hemistich of poem will be repeated at the end of second hemistiches.

Radif

Radif means a word or phrase, independent in pronunciation and repeated after main rhyme with a certain meaning (Shafii Kadkani, 1389: 123-138).

Hajab

It is a word repeated before main rhyme. It is possible to be between two rhymes which is appreciated (Karami, 1389: 161).

Chained alliteration

It means the repetition of a vocabulary, at least twice, with a pause and by some conjunctions such as of, to, and, etc.

Distributed alliteration

Where the repeated vocabulary is distributed in several parts of sentence.

Motatabe

The information which is mentioned in second hemistich so that each item is the meaning and explanation of previous one (Shamisa, 1393: 159).

Taataf

Nabolsi mentions this figure as one of the similar words is at the beginning and middle of first hemistich and the other is at the beginning and middle of second hemistich (Shams Alolama, 1377: 150-151).

Sentence or phrase repetition

Repetition in sentence or phrase level includes figures such as Tasbiq, grammar repetition, pun, Qalb Matlab, Qalb Mstavi and Rad Almatla.

Tasbiq

Where the author repeats a word or a part of first hemistich, couplet or sentence at the beginning of the second hemistich, couplet or sentence (Esfandyaror, 1388: 92-93).

Sentence pun

Pun in sentence level is where all or most of the words of two sentence is similar and there are two or more total pun. The criterion of identification is the sentence tone and stress which is called Tarsi ma' Altajnis that is not clear (Shamisa, 1393: 69)

Qlab Matlab

Some words in first hemistich are repeated in second hemistich so that a new and artistic meaning has been created. It is sometimes considered as a kind of Tasdir (Shamisa, 1393: 161-163).

Rad Almatla

The first or second hemistich of the beginning part is repeated in the end (Esfandyarpor, 1388: 93-94).

Grammatical repetition

Grammatical repetition is a trick which is not considered but it is beautiful and perfect and it is one of literature in west. It is pleasant because the grammatical figures of second part reflect those in first one. Grammatical repetition is grammatical symmetry and it is pleasant just like any other symmetry (Vahidian Kamyar, 1393: 47-49).

### Semantic repetition

What has been expressed was about music role for musical aesthetic of discourse. But it has to be considered that there are repetitions which are important semantically but not musically. Words in sentences has the ability to repeat. Repeat applies different meaning for different reasons (Jahed Jah & Rezaii, 1393: 90).

### Repetition from pragmatics point of view

The figures which are going to be introduced are important from pragmatics point of view and their expressions of semantics.

### Etnab

It is the complex text which needs interpreting. In some other literature figures such as story or play we need this figure for describing scenes and reasoning. In normal utterance when the audience has no idea, this figure is used (Esfandyarpor, 1388: 188).

### Izah

Where some additional explanation makes the utterance clear (Esfandyarpor, 1388: 189).

### Toshi'

Literally it means decorating clothes but the implied meaning is to bring something ambiguous and then make it clear (Esfandyarpor, 1388: 189).

### Iqal

It means to end up the utterance and the meaning is complete without it (Rajaii, 1359: 213).

### Hashv

Where a word or a sentence in couplet or a cause is redundant and there is no need for it. This figure is as an extra sentence. Hashv is in three kind: 1. Melodious 2. Average 3. Obscene (Esfandyarpor, 1388: 191).

### Ehteras

Literally it means to keep self away from something and it is used for ignoring ambiguity.

### Takmil

A clause where in an ambitious text to ignore the misunderstanding (Rajaii, 1359: 216)

### Tazeel

That is a sentence which is included in other sentence and emphasizes the meaning of the previous sentence (Rajaii, 1359: 215).

### Tatmim

A clause with no ambiguity is brought to make the utterance and meaning pleasant (Rajaii, 1359: 217).

### Tansiq Elsefat

It is based on a kind of repetition and that is to bring several adjectives for a noun. Of course the adjectives are not alike but semantically similar (Vaez & Kardel ilvai, 1390: 148)

### Semantic repetition from metonymy point of view

The main goal of metonymy is the repetition of a meaning in different ways for example simile, metaphor, etc. then we consider the important figures of metonymy. These two figures are allegory and equipoise.

### Equipoise

Where two hemistiches aren't apparently connected but in fact the second hemistich is the explanation and emphasis on the first part. The first and second hemistich can be exchanged. It is based on simile and the structure is a compared and linking word. It is similar to combined simile in which the linking words has been omitted (Esfandyarpor, 1388: 202-204).

#### Allegory

Where in one hemistich the issue is explained and emphasized in other hemistich using simile (Esfandyarpor, 1388: 204-205).

#### Conclusion

One of the most attractive subjects of repetition aesthetics in Persian literature which has gained a lot of attentions. In this paper as the title implies –the overlook to musical and semantic repetition in Persian Poem- they are applied based on the most important expressions and comments in different books and the selective works of poets are studied. It is found out that Persian poets were successful using different literature figures in creating image and magical sense, enhancing musical aspect and making their poems more beautiful. They were also successful using metonymy in both areas in which repetition has a lot of frequency demonstrating the sensitivity of the poets to music aspect of poem.

#### References

- Esfandyarpor, H. (1388). *The brides of word*. Tehran: Ferdos. The third Edition.
- Jahed Jah, A. & Rezaii, L. (1393). *The meanings*. Tehran: Payam Noor. The second publish.
- Rastgo, M. (1382). *The art of words*. Tehran: SAMT, the first publish.
- Rajaii, M. (1359). *Ma'alem Albalagheh*. Shiraz: Shiraz University. The third publish.
- Safavi, K. (1394). *From linguistic to literature*. First volume. Tehran: Sore Mehr. The fifth publish.
- Shafii Kadkani, M.R. (1389). *The music of poem*. Tehran: Agah. The twelveth publish.
- Garakani, S.H. (1377). *Abdaa olbadi*. Tabriz: Ahrar. The first publish.
- Shamisa, S. (1393). *Expression and meanins*. Tehran: Mitra. The forth publish.
- Shamisa, S. (1369). *An introduction to rhyme and meter*. Ferdos. The forth publish.
- Karami, M.H. (1389). *Rhyme and meter in Persian poem*. Shiraz. Th third publish.
- Nasir Eldin Tusi. (1393). *Meyar Alashar*. Ghahramani Moghbal, A.A., Tehran. University publication center. First ublish.
- Vaez, B. & Kardel Ilvari, R. (1390). *The investigation of effect of repetition in Bostan fluency*. Linguistic and eloquence studies. Number 4. PP 137-156.
- Vahidian Kamyar, T. (1379). *Rhetoric from aesthetic point of view*. Tehran: Dostan. The sixth publish.
- Homaii, J. (1363). *Eloquence techniques and literature figures*. Tehran: Tus publication. The second publish.

## A Look at the Function of Father and Son in the Epic Literature of Iran and the World

Asadollah Jafari<sup>1</sup>, Elham Choobineh<sup>2</sup>

1-Department of Language and Persian Literature, Faculty of Literature and Foreign Language, University of Payame Noor, IR of IRAN

2-Department of Language and Persian Literature, Faculty of Literature and Foreign Language, University of Payame Noor, IR of IRAN

### Abstract

The analysis and investigation of epic literature which has borrowed much of its own motifs from mythological units is a type of study which has attracted the attention of researchers in contemporary period such that it has penetrated in the field of anthropology. One of the subjects posed in epic literature is the investigation of the function of father and son in the epic literature of Iran and the world. This study, through a general look at Iran and world mythology, addresses one of the most common mythological motifs, namely, father-son epic function and attempts to result in the highest rate of frequency in the manner of father-son function in world and Iran epic literature. By investigating epic stories, it can be perceived that most of father-son epic functions are confrontational functions. The functions that lead to father and son confrontations. There are also stories which attend to father and son interactive functions. The most important and repetitive father and son interactive function can be seen in stories in which the son rises against father's revenge.

**Keywords:** epic literature, myth, father and son, interaction, confrontation.

### 1-Introduction

The legends have arisen out of written and oral narrations of nations since time immemorial which reflect social, cultural backgrounds and customs of different nations in such a way that we can become familiar with many common aspects of the nations' legends by studying these works which bespeaks of the fact that old societies are affected by each other. One of the fabulous discussions related to the legends is the function of father and son in relation to each other. When we talk about father and son function, at first glance, a sort of confrontation between father and son takes shape in the mind; however, this study, in addition to confrontation being one of the most frequent type of function, attends to other samples of father and son functions including interactive function of the cooperative and revengefulness type.

### 1-1- Literature and Methodology

Different narrations related to the function of father and son confrontation are seen in the literature of Iran and the world; however, as far as the author of this study knows, these functions have not been attended to independently so far. The only book published related to a small part of this subject under discussion is a book entitled "father and son combat" by Anthony Potter translated in Iran. The author of this book, in addition to relating different stories with the theme of father and son combat in the literature and myths of the world, attends to the investigation and the way these stories have been created. Several studies have been conducted in this regard including the article "patricide and the confrontation of generations in examples of the myths and the literature of the world" (Amiri & Bezdude, 2013) and the article "the tragedy of killing son in the myth of Iran and patricide in the myth of Greece" (ZabihniaOmran, 2000) and, also, another article entitled "a comparative study of the story of Rostam and Sohrab with several similar cases in the myth of the world" (Kamali, 2010) and another article published is a study entitled "comparing father and son combat in the stories of Rostam and Sohrab and Koroghlu and Kurdoghlu" (Rasmi & Rasmi, 2016).



This study was conducted on a library basis. First, it attends to the study and investigation of epic and mythical books of Iran and the world and, secondly, it offers examples of confrontational and interactive functions between father and son by looking at the myth of Iran and the world.

## 2- The Myth of Iran and the World

“One of the main causes of the emergence of legends is the refusal of man in accepting sins and his submission against mysterious powers which try to destroy him, powers which act, mark his future involuntarily and dominate his destiny” (Hamid, 2017: 1). The legends are considered not only man’s ideological thoughts about fundamental concepts of existence but they have orders and prisms by means of which people live. The legends, in fact, can act as a society’s logic and thinking. It is with the help of mythical concepts that a society’s registered patterns can find their dominance and ultimate authority. So, such patterns can be representative of god-like kings of England or ternate patterns of Indo-Iranian peoples. After all, this doctrine that gods have created a society in a three-layer structure can show that some people are created as priests, some other as warrior and the third group as productive workers which have all been in such a way that, in life, it presents the position of all men in accordance with the will of gods. The legends, in this fashion and mutually in the position of emphasizing moral principles, can provide patterns for people by means of which they can shape their lives (Hinelz, 2009: 2). Relating from Clod Loy Strus, William Doty writes: “we should not think that the legends arisen from the furthest time and place can only show to us the previously stage acts. They do not include acts and plays which have come to an end, but, they are indefatigable which show new plays each time at the time of recounting and relating (Doty, 2012: 14). Therefore, knowing legend means knowing the essence and origin of things and knowing the way they have emerged (Eliade, 1983: 27). ZabihniaOmran writes: “ the myths and legends form the past of nations, the myths of the world have similarity and at times they stand in contrast to each other” (ZabihniaOmram, 2008: 96). Each culture has created legends on earth, so, it contemplates about life and death and explains its secrets. It seems that making legend is one of the marked features of man like language. The legend’s delightfulness needs no justification as they transfer to us things which the people have observed for thousands of years (Burn et al, 2015: 23). So, since story telling is tied to the existence of cultures, the geography of myths can show the denial of civilizations with that very same accuracy as the emergence and fall of cities can. When the British museum shows the characteristics of a tribe in the course of time, it collects works and handicrafts from the daily lives and artistic productions of that tribe, but, the simplest tool or a pot can probably be evidence of a fanciful world which that particular tribe has lived in it via its legends. Any myth is a especial kind of story about gods and divinity, heroes and oppressed maiden, the origin of creation and natural phenomena and forgotten time and probable destiny of the time in which we now find ourselves (Burn et al, 2015: 11). Mohammad Shokraei thus writes: “although it is true that in the interpretation of myths of each nation one should take the occasions and the set of culture and the value system governing that specific group into consideration, the more we can eliminate the superficial layers, environmental features from the myths, ultimately, the more we can get to a powerful and single image which is in the form of a common nation attaching all to one sole origin” (Shokraei, 2013: 97).

## 3- Father and Son Epic Function in the Myth of Iran and the World

In view of the fact that the existence of similarity among different works is a natural thing and the fact that many of the meanings and themes are common among the writers in the world, Iran’s national epics in certain fields have common grounds with the epics of Iranian, Asian, Greek, Roman, and Mesopotamian peoples in personalities, religious rituals, beliefs, aims, etc. Many common grounds are seen between our old epic narrations with Vedas, Upanishads, Mahabharata and Ramayana in India as well. These similarities can be a result of historical, geographical and cultural relations of nations with each other or a historical experience which are near or even the nations’ mental trade in storytelling.”

Usually, the nations which have active lives having a sort of peace and war adventures have heroic epics like the Greek and the ancient Iranians; however, the nations with no foreign and extraterritorial activity have more religious and philosophical epics like the Chinese, the Egypt and the ancient India" (Shamisa, 2004: 69). Among the epic themes to be seen in the literature of Iran and the world is the epic function of father and son in relation to each other. Two of such functions include interactive and confrontational functions which are to be investigated in this study. These contents do not belong to a specific country as its trace can be seen all over the world.

### 3-1-Confrontational Function

"Father and son struggle is one of the most repetitive motifs in world myth. The high frequency of this theme in stories and the myths of nations since past has put forward this function as an all-inclusive pattern at the level of Iran and world literature. In the symbolic field, the most important theme of stories under the influence of this sequence is death in prime of life and, more clearly, a struggle between old and young and the superiority of old over young. This struggle and superiority has constantly been accompanied by the young's inexperience and idealism and the old's experience and realism (father) (Jafari, 2010: 239). In such stories, a common ground exists, homogenizing some with some others with some differences separating some from others. If this common ground presages cultural homogeneity and close historical experiences or, probably, mental trade of nations in storytelling, then it will reveal the various phases of differences, features of mental and social structure of each nation and the internal tendencies of their position in approaching such a question (Mokhtari, 1988: 211). This mythical theme has been in focus in national epics expansively. In Shahnameh, this theme is manifested in a struggle between Rostam and Sohrab and in Borzunameh, Shahriarnameh and Faramarznameh and Jahangirnameh, also, this theme has been repeated under the influence of Shahnameh (Sattari et al, 2016: 363). Anthony Potter regards this tragic event a result of the rituals of mythical marriages including exogamy and nurturing child in a matriarchal society believing that a society dominated by matriarchal system is more appropriate for the creation and development of such stories (Potter, 2005:130). Another type of confrontation between father and son is their struggle for throne, generally, seen among royal families. In Zervani myths, the oldest example of father and son struggle is for obtaining royal throne and monarchy (Sattari et al, 2016: 363). This theme is not specific to a especial nation and can occur in any society. Despite great similarity in some examples, this can be considered an extraction from other stories (Kamali, 2009: 128). As Mokhtari writes: "such stories profit from a matriarchal space at the outset of the story and a patriarchal relationship at the end as if they are stories born of the period of transiting matriarchy to patriarchy and their intertwinement; however, each is at a different condition of a society's internal struggle and existing contrariety in its life system expanding on a general worldview foundation of its nation (Mokhtari, 1989: 224-5). Some researchers do explain this struggle between father and son with Oedipus complex. Some conceive the tragic event of father and son to belack of understanding. A group of researchers look at this subject with a western-eastern attitude believing that in the east, the son is killed by his father while in the west, it the father that is killed by the son. The stories of Shahnameh are suggestive of filicide. Fathers have constantly risen against their sons, be they good or bad; however, the form of this filicide is different. One thing is common in all these stories and it is the satisfaction of the father in killing his son (Mokhtari, 1989: 227). Mohammad Snati conceives misunderstanding to be the absolute relationship of filicide with Iranian culture emphasizing that in Persian culture and literature, many examples of patricide can be seen. As an example, he points to the story of Zakhak in how he destroys his father to be enthroned while the critics have taken the question of Zakhak's filicide into account (Amiri & Bezdude, 2013: 33). Below is an example of two cases of father and son confrontation.

#### 3-1-1- The Story of An and Drisa

This story is a Norwegian type of father and son example. When An was exiled by the king of Ingliad, he spent a period of time in the abode of an old man becoming a close friend of Drisa, his last daughter. In one of the first days of spring, An said to Drisa's father: "your daughter is pregnant and I am his father. If it is a girl, then you bring her up here and if it is a boy send him to me. This golden ring should be worn as a sign. Then An headed for east. The next spring, An reached a city in which a rich widow named Jeron lived. At first he worked as a servant in Jeron's house and, gradually, attracted her attention and made her in love with him. Finally, he got married with her becoming an important and rich person. Years after, one night he saw that smoke was rising from afar from an island near the beach thinking the people of the king or the thieves have gone there to steal his belongings. So, he went there straight ahead. As he reached the island, he saw an anonymous man sitting by the fire eating out of a silver plate. In order to scare him, he shot with an arrow at the piece of meat the man wanted to put in his mouth. The stranger did not budge. He removed the arrow and brought another piece of meat. He shot one more time with the plate breaking in two. The third time, he broke the man's haft. The man raised and said: "he is destroying my things, so, he should be punished and put an arrow in the arch. An was after a refuge behind a tree. As he stood by the tree, three arrows fell right before him. Then, the two men struggled. An was the first to need rest. He asked his name realizing that he was fighting with his son, in fact, the son born of Drisa. The two returned to An's home (Potter, 2005: 63-4). In this Norwegian example, like many other narrations, the confrontation of father with son has been of an exogamous type with the son brought up in a matriarchal society. In this story, unlike many stories with this theme, the son reveals his name to his father. The end of the story is not tragic.

### 3-1-2- Arjoona and Chitrangada

Arjoona reached a city named Manipoora. There, Chitrangada saw the daughter of the king of Chitravahana and asked for marriage. When the king heard his demand, said: "only one child from my next generation of my strain will be born. All my ancestors, each has had only one son while I have this only daughter. So, my daughter should have a son in order to continue this custom. You can marry her on this condition. Arjoona accepted the king's condition and got married with her living with her for three years. When she gave birth to a son, Arjoona embraced him kindly and left the king and headed for trips again. After the end of the great war between Pandus and Kurosh in the holy land of Kurukshetra, Arjoona went to Manipura city. The governor of Vabheruhana was notified that a more high-ranking official has arrived in the city. He went to meet him humbly. Arjoona yelled at him angrily for his ill behavior saying: "certainly, you have forgotten your duties as a warrior and that I have come here as a guard of Yudhishtira's horse." O boy, why do not you fight with me? You treat like a woman. Ulupi, Arjoona's wife, heard her husband's words ordering Vabheruhana to fight with him next to his father. The son wore his armour slaying Arjoona in the ensuing fight. When Ulupi, resuscitated the dead man with Nagas magic stone, Chitrangada and Vabheruhana's severe grief ended (Potter, 2005: 70). In this narration, the child grows up in a matriarchal society without the presence of his father who rose against his father and killed him.

### 3-2- Interactive Functions

Father and son interactive function is another function seen between father and son. In this section, two of such functions are addressed.

#### 3-2-1- Cooperative Functions

In this function, father and son interact and cooperate in different fields. In the following section, two of such functions are mentioned.

##### 3-2-1-1- The Story of the Rise of Kaveh, the Ironsmith

Zahhak was the son of a devout, one of the emirs of Arab. Iblis tempted him to kill his father to replace him. Zahhak who had an impure inner self acquiesced to this deed. After a while, the satan appeared in the guise of a cook kissing him on the shoulder. The place of each kiss becomes an incurable snake. In order to be got rid of their agony, these should be fed with the brain of man. Each day, one young man was killed for this reason. Finally, Kaveh, the ironsmith, whose seventeen sons were killed at Zahhak's order, revolted (EslamiNodushan, 2015: 123). Kaveh rises with the cooperation of his last son and, also, the oppressed people and made Fereydun sit on the throne (Hinzler, 2009: 117).

### 3-2-1-2- The Story of Odysseus and Telemachos

Odysseus, before going to Trova, knew that it would take twenty years to get back to his homeland, i.e. the rocky island of Itaka and seeing his son Telemachos and his wife Penelope, he was in Trova for ten years and more ten years stranded at seas being shipwrecked. Finally, at the twentieth year, his ship run aground at the coast of his homeland's island. Odysseus, during the twenty years he had spent outside his hometown, and the people of Itaka, except his wife, and his son Telemachos and some of his faithful friends, had come to this conclusion that he had been killed either at Trova or on his way back home. As Penelope was wealthy, she was at bay by her suitors from aristocratic family who wandered around his husband's palace. Penelope would while away her time as she could and did give hope to all of them not promising even a single person for marriage. A little before the arrival of Odysseus, his son, Telemachos, who had grown up and could play a role in his father's return, decided to go on a journey inspired by Athena to figure out what had happened to his son. Telemachos went to Polus to seek advice from the old Nestor. Nestor guided him to Menelaus's palace. Menelaus explained how he had heard from the old man how Odysseus had been abandoned in a mermaid's island all alone. When Odysseus got off at Itka, Telemachos was on his way home. The suitors who had become angry at the mature behavior of Telemachos, had planned to capsize his ship on his return home. But, Telemachos entered Itka safe and sound with the help of Athena. Athena had advised Odysseus not to enter the palace and go to the hut of Iomaius, the swineherd. The next day at sunset, at lunch time, Odysseus said at his hut that he intended to go to the city and beg at the palace. Iomaius asked him to wait so Telemachos may return from the journey. The next day, Telemachos entered the hut of the swineherd with the guidance of Athena. As Iomaius headed for the city to inform people of Telemachos's return, Athena transformed Odysseus into his real shape recommending him to reveal his identity to his son. Father and son embraced each other, then, planned together and could destroy the unlucky suitor after a series of event that had happened at the palace (Burn et al, 2005: 69-71).

### 3-2-2- Vengeance Function

Another function repeatedly occurred in Iran and the world literature is vengeance function. Since this function is accompanied by interaction and the son being with his son, this function is in interactive function. In this type of function, the murdered is the father with vengeance carried out in the hand of the son. In case the son is not present, vengeance is assumed by the grandchild of the murdered or the king's errands (Jafari, 2010: 180). Jafari has mentioned twenty one stories under the influence of this theme in Shahnameh in his book entitled "Nameye Bastan Dar Bute Dastan". We come across revenge as an old epic subject in different national myths (Shamisa, 2004: 39). In the Egyptian mythology, Horos, the son of Isis and Oziris, rises against his father's revenge (Burn et al, 2005: 374-80). In Shahnameh, many examples of father and son revenge are seen. At the time of Kiyoomars's monarchy, Hooshang gird himself in his father's revenge, i.e. Siamak taking his revenge from the devils. Fereydoon mutinied against Zahhak in his father's revenge who, finally, captured him (Sarami, 1984: 656).

### 3-2-2-1- Sigmund and Sigurd

This story is a Skandinavian type in which the son rises against his father's revenge killing his father's murderers in a military campaign. The story is so that Sigmund got married with a king's daughter named Hiurdis. His unsuccessful rival in this love was one of the sons of Hunding named Laniguy. Laniguy felt being stuck in a situation in which he should take action. So, he killed Sigmund. He attacked Hunland proclaiming war to Sigmund. The struggle with Sigmund-who had now become old, but, bravely defending himself-was a difficult one. During this struggle, a one-eyed man named Udin appeared wearing a black cape, a soft hat and an arrow in hand. This man becoted Sigmund with hoisted spear. Sigmund's sword became shredded as it stroke the spear with Sigmund receiving a deadly scar. Hiudis who was pregnant lay in ambush in a safe place in the jungle with the imperial treasures. She, while searching in between the wounded, found Sigmund in a state that was grappling with death. Sigmund predicted the position of the son born by her advising Hiuris to keep the pieces of the sword for his son. Sigmund died after conversation with Hiuris being protected by a group of wikings while the son of the king of Denmark assumed their leadership. Sigurd grew up honourably in the court of the king of Denmark and his trainer was a blacksmith named Regin, the discontent brother of Fafner now protecting the wealth he had stolen in a committee of a dragon. Regin trained Sigurd as a prince; however, trying to make him discontented of the position he held in court. Regin tempted Sigurd to obtain money telling him that he knew where treasure lay by a dragon named Fafner protecting it. However, Sigurd needed a sword with which he could kill the dragon. The made several swords, but, they all turned into pieces after being struck on the anvil. Sigurd went to his mother asking her to give him the pieces of the sword of his father she had kept so many years. Sigurd made a well-made blade using the pieces of the sword and, before attacking the dragon; he launched a military campaign against his father's murderers and killed them (Burn et al, 2015: 322).

#### 4- Conclusion

Myth has a long history in the literature of Iran and the world embracing an important part of a country's literature. A search in epic and mythological themes reveals many of the hidden and unconscious layers in the legends. The existence of similarity in such works is a natural thing with many of the meanings and themes common among the writers in the world. Iran and the world's epic literature are filled with stories showing the types of father and son function in the myths. These functions do not just boil down to confrontational types. Cooperative and vengeance functions in which the son rises in order to take revenge of father can be among the interactive functions between father and son. The most common and frequent type of function belongs to confrontational one and the most frequent type of interactive function is revenge function.

#### References

- 1- Eslami Nadoshan M. (2013). The Life and Death of the Gladiators in Shahnameh (10th ed). *Enteshar Company*, 123.
- 2- Eliadeh M. (1983). translation of Jalal Sattari, Perspectives of Myth. Tehran: *Tous Publishing*,20.
- 3- Amiri S. and Bezdodeh Z. (2013). Paradise and the confrontation of generations in examples of mythology and literature in the world (sixth period). *the critical language & literary Studies*,33.
- 4- Bern et al. (2015). translation of Abbas Mokhtban. World of Myths (4th ed). *Nashr-e-Markaz*, 11-23, 69-71.
- 5- Potter M. A. (2015). Battle of father and son in the world literature. *Eidon Publishing*, 63-70,130.
- 6- Jafari A. (2010). Ancient Letter in the Book of Truth, Tehran: *Elmi Farhangi Publishing Company*, 239.
- 7- Hamid Sh. (2016), A Look at Myths in Ancient Persian Literature. *International Congress on Language and Literature*,1.
- 8- Dati W. (2012). Mythologists of the World. *Tehran Ostooreh publication*, 14.
- 9- Zabihnia Omran A. (2008). The Tragedy of Childbirth in Iran. *Mythology and Fostering in Greek mythology. Nameh-e-Parsi Journal*, 46-47, 96

- 10- Cerami Q. (1994). From the color of flowers to the thistle: *Elmi Farhangi Publishing Company*, 656.
- 11- Shokraei M. (2013). The Fame of Being Championed by Symbolic Birth in Myth and Legend, *Adab Pazhuhi Journal*, 26,97.
- 12- Shaimsa S. (2004). Literary Types, Tehran: *Payame Noor University Press*, 69.
- 13- Kamali M. (2010). Comparative Study Of Rostam And Sohrab With Similar Stories From World Mythology. *Pazhuhesh-E Zabanha-Ye Khareji*, 55,128.
- 14- Mokhtari M. (1989). Saga in National Mystery. *ChapEntesharat Publishing*, 211-227.
- 15- Henels J. R. (2009). Iranian mythology. Tehran: *Institute Of Islamic Art Studies*,2, 117.

## Bashkir Epic “Ural-Batyr”: Traditions of Its Modern Recitation and New Projections of Its Archaic Character

Rosalia A. Sultangareeva

Institute of History, Language and Literature, the RAS Ufa Science Centre

### Abstract

The urgency of the study is caused by the need of a comprehensive study of the live (authentic) version of the “Ural-Batyr” epic kept in people’s memory. Given that until recently, oral performance, improvisation and the chants of the epic themselves were believed to be irreversibly lost, the study is especially relevant. The objective of the article is a comparative analysis of this oral version with the main published version introduced into scientific use earlier, find out the differences, based on the found lines reveal semantics of the myth, linguistic and sign codes, and mythopoetics of important episodes. The main method of the study is the artifact and mentifact detection and comprehensive study of the chants, which allows reconstructing the strata of the epic of the Upper Paleolithic (the 3rd–2nd millennia BC). The main finding of the study based on the comparison of the live recitation with the published version is that some poetic lines are missing in the latter, as well as some plot motivations, informative in their deeply archaic mythological projection, and the most complete descriptions of Akbuthat and Ural-Batyr. Four epic proper chants common for the traditional practice have been revealed. Based on the reconstruction and new interpretation of the text, particular evidences of anthropogenetic links of a human and the winged horse Akbuthat, as well as of mythological and musical traditions that allow stressing the initial text of the “Ural-Batyr” epic in the world epic tradition. An analytical description of the body language and emotional and expressive component of the narrator’s performance has been provided. The data of the paper can be of use for humanitarians in the study of modern revival of epic traditions, in particular, of the Bashkir “Ural-Batyr” epic, a prototext for numerous Indo-European, Vedic, and Turkic-Mongolic subjects.

Keywords: narration, “Ural-Batyr” epic, folklore memory, live epic recitation, traditions, myth, rituals, anthropogenesis.

### Introduction

The “Ural-Batyr” epic is the main Bashkir folklore work. It consists of 4576 poetic and 19 prosaic lies. The genre of the epic is *kubair* (or *qobajär*, from *qoba* ‘the best, strong’ and *jär* ‘song’).

The text of the archaic “Ural-Batyr” epic “was the key fact in spiritual beliefs of the Southern-Uralic people of the 3rd – 2nd millennia BC” (Kotov 2009, 337), which implies an even more archaic mythological basis of the epic. The main image of the Ural in the calendar-astronomical epic, the creation of which took over four thousand years, conveys the idea of the Earth (Ural -- Weralt) being born in spring and dying in winter every year (Gallyamov 2007, 9). It is thus comparable to the Sumero-Akkadian and Indo-Iranian mythology and biblical stories of the flood; it contains a number of striking similarities with the Sumerian Epic of Gilgamesh and references to the names of real people who lived four thousand years ago (Sumerian king Shulgi, his son Bur-Sin, governor Zariqum, etc.) (Gallyamov 2000, 145). The original version of the epic dates back to the Upper Palaeolithic (Kotov 2009, 338). The “Ural-Batyr” *kubair* is known in seven records of “tale-like”, short epic, and “legend-like” versions (Suleymanov 2013, 199).

Many scholars have studied The “Ural-Batyr” epic, covering its different aspects: its mythological properties (N.A. Kireev, A.I. Kharisov, A.S. Mirbadaleva, M.M. Sagitov, R.F. Rezyapov, F.A. Nadrshina), mytholinguistic and linguistic (G.Kh. Bukharova), poetic and stylistic (G.V. Yuldybaeva, G.R. Khusainova), mythopoetic (A.M. Suleymanov), archaeological (V.G. Kotov), philosophical

(D.Zh. Valeev, Z.G. Aminev, Z.Ya. Rakhmatullina), textological (Sh.R. Shakurova), folkloric and ethnographic, myth-ritual properties (R.A. Sultangareeva). These researchers study the publications of 1968 and 1972. The issues of specific features of live performances and improvisations, manners and cultures of the body language, textual underlines remained beyond the scope of their works, since there was no opportunity to compare the texts with authentic recitation.

The present work examines the layers of antagonism between a human and a horse, the cult of a deer, specifics of the body language, as well as semantics and mythopoetics of the most significant episodes of the authentic version of the epic that was found by the author in 2011.

The most complete text of the epic was wrote down in 1910 in Baymakskiy District of Bashkiria by M. Burangulov from *seseny* (storytellers) G. Argynbaev (1856–1921, Idrisovo village) and Kh. Almukhametov (1861–1923, Malo-Itkulovo village). Thereby in the 20th century, the great epic poem, which had been performed in the oral form for many centuries, and as a legal code, had played the most important role in spiritual life of the Bashkirs, was returned to the people who created it. However, due to a surge of cruel persecution against folk singers and storytellers and a series of prohibitions, the epic poem could not be found in live performance and had not been studied by any scholars for a long time until it was finally published in 1968 and “introduced into scientific use, which was a significant event” (Shakurova 2007, 7). Later, several other publications and revised editions of the epic were published in Bashkiria (BXI 1972; BNT 1976; BXI 1998), and later in the Bashkir, Russian and English languages (BNE 2003). The All-Russian scholarly publication took place in 1977 (BNE 1977, 55–102, 265–373).

Among the main themes of the epic there are the formation of the saving ideology of Goodness (*Jaqşalaq*) against the background of the time after the Great Flood, the years-long struggle of Ural-Batyr with Death, his search for the eternal Spring of Life, and the emergence of the Ural Mountains from the body of demiurge Ural-Batyr, who found the solution for the secret of eternal life in the service of his people and his homeland. Swallowing (*jotow*) is a traditional symbol of any astral-calendar mythology, symbolizing the cult of dying (sunset, falling of stars, autumn) and resurrection (incoming of the Day, Spring, new times, etc.). Ural-Batyr swallowed *daeva* (dragons) and all evil spirits, and taking a full mouth of the lake water, where the dragons were hidden, sprayed it on the land, upon which the Ural Mountains appear.

The epic was transmitted by word of mouth through successive generations of narrators entrusted with its reproduction. At the beginning of the last century, the epic was still recited during festivals and family meetings. Its “tale-like” versions written down by A.I. Kharisov (1956) and G. Safargalina (1984) are known. However, after 1910, there was no comprehensive recording (audio and video; word + melody + gestures) of the main body of the epic, performed in its oral form, recited with chants. In 2011, the author’s methodologically verified search yielded results: the epic was recorded in a live oral version that differed from the basic variant (BV) in some significant episodes. 81-year-old *seseniya* (female storyteller) A.M. Usmanova (1930–2015) was reciting the “Ural-batyr” epic with chants for nearly two hours, having recovered from memory some earlier unknown and extremely valuable mythological, ethnographic, linguistic, and other evidences.

Epic is a narrative poem, which is significant in its monumentality and coherent transfer of the deep history of the land, world, and its inhabitants, typical of indigenous peoples only. The main genre, instrument, and the pinnacle of the Bashkir epic tradition is kubair (*qobajær*) -- a heroic song about the land, soul, and history of the people that has been composed by *seseny* since ancient times. Both the etymological and semantic parameters of the genre are polysemantic: it is the best glorifying (*qoba*) + song (*jær*); a song about heroes (BXI 1981, 112); it can refer to ‘a tribal hymn’, ‘people’s song’; the lexical unit *qoba* has the following meanings: ‘soul’, ‘good’, ‘colour’, ‘quality’, etc. *Qoba* is related to archaic notions



of *oba*, *obo* -- stone or wooden fences built as markers of tribal cult places. Certain light grey colouring patterns of cult cows (*qobahəjər*) and geese (*qobaqađ*) are also associated with the semantic field of “best” / “sacred” / “symbolic” (in folk tales, *qobahəjər* is a sacred animal; an apple tree grows from the bones of the buried cow; the cow helps the heroine). The primal etymology associates the genre of *qobajər* with the Old Turkic word *qoba* meaning ‘finely crafted skin’ (BTH 1993, 665). Against this background, one can project the original roots of *qobajər* functions as sacred ancestral legends, which once, in pre-literate era, were recorded with the use of drawings or symbols (*tamga*) on a piece of thin leather (similar in properties to the parchment) and transmitted through generations by dedicated educated people. The Bashkirs used to record their myths, secret knowledge, and predictions on leather (birch bark, stones). An oldest book “Fakihtar jazəwə” (“Writings of Savants”) was written in red ink (*zagfran*) on a fish (catfish) skin, and its cover was made from bovine hides (BXI 2004, 357–358, 589). This unique book tells about the events of the Bashkirs’ life since pagan times, with descriptions of long-term travels of sages and brave *batyrs* in search of a new religion, until the start of urban developments and uprisings of 1740–1750. In the historical epic “Idukay and Muradym”, the main hero learns about the predestination of his fate from a book written on deerskin (İdükäj menän Morađəm 1994, 149). Thus, the folkloric source has preserved authentic memories of the ancient realities. In this context, it is logical to assume that Bashkir kubairs are sacred texts of tribal hymns and sacred chants that were recorded on leather sheets (*qoba*) in ancient times and have been orally transmitted over centuries from one generation to another by *seseny*, these artists of the Word. The specifics of origin and functions of the genre, which is ethnogenetically associated with the death wail expressing grief and praise for the dead warriors, are reflected in the semantics of the term “a glorifying song” (Sultangareeva 2006, 201–202).

Due to the absence of authentic oral recitations by traditional performers, the “Ural-batyr” kubair became the subject of violent discussions of the mere fact of its existence. The theory of creation and identity of national epic necessarily presupposes the existence of variants and versions of the epic (as well as of all folklore genres) and its existence in the performing practice.

Preserving living traditions of oral epic performance by representatives of the nation-creator of the epic is one of the mandatory conditions for ethnic, historical, and genealogical identification of this genre. A recited epic poem can be regarded as a cultural text even if it is fragmentary and incomplete, but it must be an oral tradition transmitted by word of mouth and performed live by heart. Such method of live translation of the epic text to the audience reveals the most important constituent features of the folkloric genre: variation, improvisation, linguistic and melodic characteristics peculiar to a specific nation, links between the style and performing standards, canons, and traditions, as well as the expression of the national and universal ideals in the epic. For many years scholars have been trying to find narrators able to deliver the great epic. Valuable information was found in the memoirs by B.Z. Bilalov (2009) who said that in their childhood, they used to spend whole nights listening to the epic recited by Kinyabika Yulanova (a native of the village of Verkhne-Smakovo, Zilairskiy District, Republic of Bashkortostan), and the young listeners were greatly delighted with her masterful performance (Yuldybaeva 2011, 107). 2011 was a landmark year for the further methodological search: a live performance of the main body of the epic was recorded in the unity of prose and verse pieces, preserving linguistic, gestural, melodic specifics, as recited by Asma Usmanova (Akyar village, Khaybullinskiy District, Republic of Bashkortostan), a famous narrator and connoisseur of folklore and national culture. A.M. Usmanova was a representative of a noble and ancient family of the Turumtaevs; her grandfather Gabdelyahat Turumtaev (1864–1942) was a disciple of Zaynulla Rasulev (1833–1917), an outstanding specialist in Turkic philology, “Bashkir *išan* and a follower of Sufism, religious figure” (Farkhshatov 1996, 493). G. Turumtaev was known for his improvisatory talent, and he skilfully sang folk songs and tales during national congresses (*jəjən*), fascinating the audience with his performing art. His wife -- and A.M. Usmanova’s grandmother -- Mu’mina Taymasova (1870–1973) was a true connoisseur and talented performer of Bashkir chants, myths, folk tales, and religious stories. She used to tell “Ural-Batyr” epic to

her granddaughter. A.M. Usmanova's father Mavlyanbirdy Turumtaev (1909–1993) was known for his beautiful voice and was an excellent performer of folk tales and songs. The fragmentary data on the narrator's ancestry are consistent with the traditions of transmitting folk works only to the chosen spiritually educated individuals possessing strong, deep memory.

### Methodology

Recording of the epic recited by A.M. Usmanova was made in compliance with all principles and methods of the folkloristic genre description and rules of establishing and determining originality and authenticity of the unique text:

- 1) genealogy of the oral transmission of the folk tale was restored (great-grandfather -- great-grandmother -- grandmother -- narrator herself);
- 2) multiple recording were performed (in September 2011, October 2012, and June 2013) in order to determine the correlation between improvisational and traditional parts and to exclude the possibility of a written source or a staged transmission of the text;
- 3) a video of each session was also recorded to exclude any possibility of artificiality or stylisation based on a book version and to obtain a proof of this extraordinary significant event; the complete two-hour-long recital of the epic by Asma Usmanova had live TV coverage on BST channel of the Republic of Bashkortostan on 15 November, 2015;
- 4) in compliance with the requirements of the contemporary visual anthropology, during the epic recitations, all significant gestures of the narrator, her costume style, emotions, and the manner of presentation were described ("the narrator is thinking", "she is stopping", "she is recalling", etc.); we also took into account the environment and audience, time, etc. The authentic text of the oral recitation of the "Ural-Batyr" epic was published in the original language (Sultangareeva 2012, 219–244).

Asma Usmanova learned the kubair from her grandmother Mu'mina Taymasova and took over many specific details of the epic recitation in the process of repeated listening (from the age of 9 to 16 she frequently lived with her grandmother). Her delivery of the epic was most complete, with entire storyline rendered in the unity of melodies, recitative chanting of poetic and prosaic parts, elements of body language and narrator's comments. Creative attitude of A. Usmanova and her culture of storytelling should be mentioned: a dignified and calm manner of delivery, expressive, but not excessive intoning of voices of main heroes and other characters (Humai-Humaira, Akbuthat, Yanbirthe, Ural-Batyr, and others), general life-affirming pathos with didactic elements, etc. According to A.M. Usmanova, she reproduces all these components "exactly as heard and learned from grandmother". For almost two hours (total time was somewhat different during other sessions), A. Usmanova was continuously reciting the epic, chanting the melodies and sometimes making philosophical digressions from the main story (it is a traditional device used by storytellers when performing long narratives). Any possibility of retelling an intentionally memorized book version of the epic was excluded from the very beginning due to the trust and respect for A.M. Usmanova, who honoured the cherished memory of her ancestors and her grandmother Mu'mina Taymasova, and always affirmed that she knows "no other text, and will tell only what she heard and what grandmother taught" her. A.M. Usmanova enjoyed great respect among the people; she was granted the Excellence in Public Education of the RSFSR award -- all her life she worked as a mathematics teacher (which confirms she had a good retentive memory); she organized a folk ensemble "Koş julə" ("The Milky Way") and had been managing its activities for 25 years. She had not recited the epic earlier for the following reasons: 1) she got to know that the published written text differed from the text she knew; 2) nobody asked her to do it; 3) she always remembered the words of her

grandfather about a strict ban on performing epics and legends in former times, and therefore she was wary of storytelling.

### Results and Discussion

The newly discovered text is the longest of all the versions written down after 1910. It is unique because of its good preservation in oral recitation. The text is indicative, since it has accumulated archaic artifacts and traditions of the performing practices in the context of a new interpretation of the “Ural-Batyr” epic. In order to reveal the epic, more than 1000 people were interviewed, especially in 2003–2012, and the search continues. The high value and really exclusive character of the discovered new variant of the “Ural-Batyr” epic (which is certainly shorter than the known BV) in oral recitation are confirmed by the following:

1) During all repeated recording sessions, A.M. Usmanova recollected new details of the plot, words and lines that are missing from the BV of the “Ural-batyr” epic but logically fit into it. For example, in the description of the mythical horse Akbuthat descended from the sky, she told the following lines:

Qarsəya tüş, tar böjör,	The breast of a hawk, narrow hips,
Qəjyər bərköt qanatla,	Wings of a wild golden eagle,
Azdaha-jəlan tamaqla,	The neck of a dragon or snake,
Ütker qələs tərnaqla,	His claws are sharp as a sword,
Ikheð-sikheð bolottay ti,	And his wings seem boundless
Unəñ ike qanatə.	Like clouds in the sky (Sultangareeva 2012, 231).

Akbuthat, a miraculous celestial horse, thus seem to have features of a bird, dragon, celestial horse, breast and snake. In the BV, one cannot see such lines associated with multitude images and intentions, allowing to reveal the genesis of the winged horse. At the same time, five different traits combined in one image objectify much more ancient archetypes and mythological genealogy. Antagonism between a human and winged horses is typical of mythological traditions of peoples from a large areal (South and Middle Asia, Caucasus, Europe, Siberia, and Mongolia), as well as in Abkhazian myths (Berezkin 2012, 35); negative associations of a horse are also registered in the area between Greece and Scandinavia and the Hindu Kush (Ibid., 36). This motive is found in the Ural as well: in the Bashkir folklore, a miraculous horse chooses a batyr, his tamer, only after a battle with him (Yäşägän, ti, batərđar 2005, 194, 294). In the “Ural-Batyr”, Akbuthat descends from the sky, it doesn’t fight with the hero, but lays down conditions. This is a metaphoric key to realization of manifestation of a materialized divine being, directing vital spiritual movements of the people. It is known that the myth “proclaimed a horse a relative of the dragon, akin to the mysterious powers of water. Indeed, all wonderful horses were considered avatars of dragons, and in antiquity the tallest horses owned by the Chinese were called simply ‘dragons’” (Schafer 1981, 88–90). “Avatar” is a Sanskrit word, a term of Hindu philosophy meaning “a descent to Earth of a deity incarnated as a mortal”. It means that Akbuthat is a visible manifestation of a winged dragon with claws and a serpents’ neck. He is omnipresent: he connects the sky, earth, and chthonic world. In the context of identification of the cardinal directions with colouring patterns of horses (Rudenko 1960, 185), Akbuthat (“White winged horse”) represents the god of horses in the Bashkirs’ worldview, which was marked by Ibn Fadlan as early as the 9th century (Kovalevsky 1956, 27). The unity of various images in the horse-dragon descends to the omnipresent polymorphic image. By its etymology, it is not only related to Iranian Indo-European tradition, as it is usually believed, but also has proto-Turkic roots (Kondybay 2008, 35). It has also preserved the memory of archaic vestiges of Chinese mythology, which has lost its integrity and diversity over thousands of years. Many faces of the epic horse are a property preserved

only in the most archaic mythologies and epics of the world. Akbuthat acts as a symbol of the omnipresent ancestor and a code of materialization of the unity of different principles of nature and knowledge, ways to struggle and victories.

The following lines (also absent in the BV) are significant because of the emphasizing the role of the horse in the anthropogenesis of the Bashkirs:

Oloyajyan qarttə la    If an old man jumps on it,  
Menhä, jəp-yäš ir iter.                                      He instantly becomes young (Sultangareeva 2012, 231).

The idea that the man descended from the horse can be found in myths of the Sakha-Yakuts (Emelyanov 1980, 2-16), Kazakhs (Kondybay 2008, 38), and Bashkirs. Thus, for example, Batyr Buzansy was born from the womb of a mare in human shape (Mingazhetdinov 1971, 301-304), and in other cases a grey mare brings a grey colt, which on the third day turns into a child who is to become a great hero. Traditions of "carrying a child under the stirrup" without dismounting and passing under the running horse are parallel to the traditions of many other Turkic-speaking peoples. They are meaningful in the scheme of anthropogenesis, according to which a man descends from a horse. In this context, the text recited by Asma Usmanova turns out to contain evidences of the fact that winged Akbuthat is the materialized embodiment of great powers and the creator of *Homo sapiens*, or *Homo sapiens* himself. In the version of A. Usmanova, Akbuthat is presented as a metaphor for the genetical material, new thinking required for revival and reproduction of strengths of a person (man) in the next new turn of time. A. Usmanova's narrative thus specifies the idea of Akbuthat as a celestial being descending from heavens to proclaim the coming of a new time to the whole mankind: "This horse descended from the skies, All the people were amazed, New time began, A rainbow flashed in the sky, Life brightened up on earth, The seas subsided, rivers stopped, and the lakes smiled..." (Manuscript of the record of 2013). In the BV, there are no such evidences of epochal sign of the celestial horse arrival. According to A. Usmanova, Mu'mina-inäj specified that "Akbuthat lives and brightly shines opposite *Timer kazyk* (North Star)" among the stars. In her text, Akbuthat's great power and ability to work wonders, his fire-and-sun nature are presented. "Flapping wings like a gerfalcon, Sparkling like a ray of fire, He is coming down to earth; He will boil sea waters, He will stop river waters, He will dissolve clouds in the sky And start whirlwinds on Earth...". Akbuthat is the horse of Samrau, the king of birds, and his wife Sun, hence the richness of the solar symbolics in his image. While in the BV, it is only the saddle and reins that are called "golden" (BXI 1998, 92), in the text by A. Usmanova, Akbuthat has golden reins, stirrups, the scabbard of the damask sword, saddle, horseshoes, and crupper-strap (Sultangareeva 2012, 230). The solar symbolics, which is universal in translating the knowledge on the dualism, confrontation of the opposite principles, four corners of the earth, manifested especially in the jewellery of the 3rd millennium BC -- 3rd millennium AD (Obydenov, Korepanov 2005, 84). Thus, Usmanova's text not only has preserved in Akbuthat's image the ideas of a bearer of light, warmth, and connections with the other world, but also projects the chronological limits of artistic traditions of the image forming. Taking into account that "in Bashkir folklore, the land of immortality associates with the land of Sun" (Kotov 2005, 95), Akbuthat is an ever-living horse (of dreams, victory, etc.). The text has captured the plot codes about the anthropogenic relation of a Man and a Horse, of the Man's being born by the Horse (a metaphor of the man becoming stronger through the hardship). In the story about a deer swallowed by a snake, according to A. Usmanova, a unique hardness and unbreakability of antlers, their role in the family wellness and omnipotence are emphasized (Sultangareeva 2012, 222), which is consistent with the cult of a Hittite god Rund, a god of revival and initiation (Ardzinba 1977, 120), reincarnation magic and the deers's ability to transfer his qualities to other animals and snakes (Ilimbetova, Ilimbetov 2012, 344).

The narrator's gestures are very informative: while telling that Humaira (that's how the grandmother called mythic Humai) "is gently stroking the horse, starting with the hair on his forehead, and running her fingers through the mane", the narrator showed this movement every time with her hands with a special emphasis, and only then she continued: "Then Akbuthat bows his head before Humaira" . This

detail is also absent in the BV. The narrator repeated this gesture in all recording sessions. Analysis of the functional gesture suggests that it is a ritual accentuation of the idea of divine horse domestication. The magical properties of Akbuthat's hair, mane, and tail (Khisamitdinova 2010, 19) are connected not so much with the horse divinity as with the fact that the soul of a dragon (*Aždaha*) or a horse (snake) is, according to myths, in their manes. The special ways of treating hair and manes (touching, singeing, burning, hiding and storing for the purpose of getting help, etc.) are traditional ritual acts in both Turkic and Slavic folklores, which are associated with magical properties of hair and special functions of the rituals: the cultural hero is granted new powers, gets to know news, obtains necessary assistance or is saved from death. The mythological code of grasping the mane (hair) is traditional of taming a mighty horse in the "Akbuthat" epic poem (BHI 1998, 139) or a water maiden in the "Zayatulyak and Hyuhylyu" epic poem (Ibid., 181), maiden-duck in the "Sanay-Batyr" tale (BNT 1989, 346-347), demonstrating the way of taming mysterious creatures. Thus, Humaira's gesture contains her appeal to the soul of Akbuthat through the horse's mane and translates the ancient knowledge about the genetic relationships of the horse (dragon) and the man who tamed it. Taking into account that "in the serpent-like (horse-like) image Great Mother manifests herself, who acquired the shape of a horse in the Bronze Age" (Kondybay 2008, 39), the taming of Akbuthat in his golden decorations before he met Ural can be logically connected with the archetype of Woman (Foremother), or Sky-Mother. In former times, the horse might have been tamed by the Woman-Foremother, Berana (from *ber* 'one, single' and *ana* 'mother'), a goddess of the proto-Turkic mythology, or possibly it was her who acquired the image of Akbuthat herself. Throwing an object over the head and a shoulder is a gesture of sacrifice in the archaic culture. A. Usmanova showed how Ural-Batyr, with his back to people, threw a 70-pood stone onto the daevas's land. In A. Usmanova's version, it is a woman who declares the main epical idea of Goodness (Jaqşäləq):

Jaqşäləq aldap kitmäj, Goodness won't deceive you,

Mänge jäšäj qan esmäj. Living eternally, it does not drink blood -- Goodness! (From the author's archive)

In the BV, these words on Goodness are told by an old man who is suffering from his immortality after he drank the Water of Life. A.M. Usmanova recalled it during the third recording of the epic (September 2013), having added that a man-"skeleton" (*höldä*), "barely alive", also said prophetic words about Goodness (Jaqşäləq). This oldman also refers to the death "as *jola*, a way of a person's transition to a new life". With every recording, the narrator recalled more and more details of the epic, which proves that we observed an extremely interesting authentic recital based on the living oral tradition. There could not be such revelations and findings of the genetic Memory, complying with the nature, plot and other specifics of the great national epic, in a memorized book version or a specially rehearsed performance. Revealing of new nuances, meanings, and details of the plot with every repetitive recitation is a significant property of any folkloric work as a living phenomenon.

The descriptions of Ural-Batyr and Humaira's appearance, which are also absent in the BV, are especially informative. "Ural had long light hair and large blue-green eyes, he was handsome and well-proportioned. Humaira had long hair, light as rays of the sun, and blue-green eyes". From the point of view of historic anthropology, such somatic characteristics comply with the genotype of many Bashkir clans, "whose racial genesis can be traced to the most ancient Sako-Massaget Europeoid population that lived in the Southern Urals in the Sarmato-Alanian period" (Yusupov 2008, 322). Therefore, in the text, the Europeoid archetype of Ural-Batyr is reproduced.

The melodic structure of the epic turned out to be very valuable and vivid. A. Usmanova performed five episodes, and the melody of almost each of them (memorised exactly as performed by M. Taymasova) has its own unique sound; these are 1) a dialogue between Humai with Ural (but Ural does not sing); glorifying of the damask sword; 2) chanting conversation between Humaira (Humai) and Akbuthat; 3) Akbuthat's speech; and 4) glorifying of Akbuthat. They are original in their archaic voicing, simple and laconic, though informative in their translating musically the main ideas of the epic plot (Sultangareeva 2015, 33-39). While the epic tradition was obviously interrupted, the revival of epics in recent times

(Yusfin 1989, 34–36) and, consequently, chants, is a unique phenomena. Considered lost forever, they are reproduced in the folklore mind as the evidences of the powerful school of the Bashkir storytelling. The concluding kubair glorifying the Ural land -- *Uraləp jatqan Uralda* ('On the Spurs of the Ural Mountains'), which A.M. Usmanova performed at the end of the epic with the melody, is quite ingenious.

Uraləp jatqan Uralda	On the spurs of the Ural mountains
Aqbuđattaj at menep,	Mounting such horses as Akbuthat,
Qarsəyalaj taw jelep,	They fly over mountains like hawks,
Uq-hađayən qulya aləp	Arrows and bows in their hands...
Təwyan ilgä doşman kilhä,	If an enemy dare to invade our land,
Yawya səyər uldar bar!	There are batyrs to protect it!
Bar! Bar! Bar! Batərđar bar!	Yes, yes, there are. There are batyrs! (Sultangareeva 2012, 243–244).

The text and melody of this chanted kubair are well known, but it had never been comprehensively recorded in such unity of words, poetic elements, abundance of images and richness of its meaning. The kubair organically performs a function of relieving a psychological stress caused by the death of the main hero - Ural-Batyr -- at the end of the narrative. When asked whether Mu'mina-inäj performed this melodic kubair at the end of the epic, A. Usmanova gave an affirmative answer and added, "That's why I memorized both the chant and this long text glorifying Ural with such accuracy". The first above-mentioned melody is similar to *munajats* (chanted religious hymns), but the last three melodies, in our opinion, should be regarded as epic proper. These melodies, which previously had not been known to scholars, are of great interest for the musical theory. By their sound they organically correspond to the character, national atmosphere, and mentality of the epic. The epic melodies were created many centuries ago, so they contains the code of the primeval magical process of understanding realities of the world through the sound; as the most conservative phenomena, they could not be lost over time and disappear. These chants continue their life in folk games, dances, and even in charms and spells (and we have seen evidences of this many times). Asma-inäj used the word *qarhüđ* 'black word' referring to the genre of the "Ural-batyr" epic. It is an archaic cultural notion meaning a word from earlier eras and knowledge coming from the times of the black ignorance, from the very beginning of being, i.e. it means a myth in the Bashkir culture. This evidence of preservation of this term in the folk memory and its use not only with reference to the "Ural-batyr" epic but also to other epic narratives, beliefs and folk tales is very important and has a significant research value. There are all pre-requisites for the revival of the word *qarhüđ*, meaning a myth in the Bashkir culture, and for its actualisation as an academic term used for classification of the respective genres. *Qobajər* (kubair) and *qarhüđ* (karkhuz) are true Bashkir terms meaning an epic and a myth respectively. It is impossible to replace native terms with a foreign word *dastan* when speaking about the Bashkir folklore. Any term is an emblematic word with the long-term code of generalization of the national traditions based on which it was created and to which it belongs.

### Conclusions

Finding and recording of the "Ural-batyr" epic was an event of an exclusive historical value, and we qualify it as a discovery of not only national but universal importance. This discovery makes us believe that there will be found other evidences for establishing and interpreting new epic parallels in the perspectives of studying the great epic. The present fragmentary analysis shows that the epic version of

A. Usmanova contains many features that have been previously unknown in the Bashkir epic culture, which is natural for an authentic delivery of an oral tradition transmitted by word of mouth.

A. Usmanova's version of the "Ural-batyr" kubair is the second longest and rich in context after the epic text recorded by M.A. Burangulov in 1910. Asma Usmanova is a national genius, whose excellent memory preserved and transmitted the sacred epic exactly as it was recited by her brilliant grandmother Mu'mina Taymasova, who lived until age of 103. These culture bearers pay homage (*namys*) to the Bashkir people, memory of their ancestors and their history! Oral text has preserved archaic layers of the mythic astral-calendar epic formation, which remain unknown to the modern scientists. New evidences for anthropogenesis folklorisation, multidimensionality of the horse-dragon, cult of the deer have been revealed. Melodies proper of the epic that had been considered irretrievably lost in old times have been found, as well as specifics of the body language. Live performance of the "Ural-Batyr" epic was shown as a unique fact due to its numerous aspects: textual, performing, melodic. The revival of the oral tradition of the epic recitation is an evidence of the spiritual integrity, strength of the linguistic culture and national philosophy of the Bashkir people. It is definitely not a mere coincidence that the mechanisms for distinguishing between the good and the evil, lies and truth, and for developing contacts between people and their relations with the nature, as well as opinions about common ideals and ways to the future, which are expressed in the national epics, are recurrently reproduced in the Memory of the people. They remind us that it is urgent and highly relevant now to use these national treasures to reproduce the human Spirit in the 21st century. The oral tradition and contemporary practice of the epics recitation prove the high historical and cultural reputation and strength of the people that created them. The people that continues to perform national epics lives, creates, and has enough strengths to reproduce its spiritual potentials in the Time. However, the danger of extinction does exist (Sultangareeva 2013, 140; Bukharova 2013, 49). The UNESCO Convention mentions "performing arts, oral traditions and forms of expression, including language" (Mukhtarov 2011, 15), the importance of "forms of expression in practice by specific bearers of the respective culture" (Ibid., 15). The discovery of the live version of "Ural-Batyr" and the performing art of A.M. Usmanova provide a concrete and very significant argument in favour of a unique character of the epic itself and Bashkir oral tradition in whole as constituent elements of the world culture worthy of inclusion on the UNESCO List of the Intangible Cultural Heritage of Humanity.

## References

- Ardzinba, V.G. 1977. "Zametki k tekstam khettskikh ritualov" [Some Notes on the Texts of Hittite Rituals]. *Vestnik drevney istorii*, 3, 116-29.
- Berezkin, Yu.Ye. 2012. "Rekonstruktsiya syuzheta sozdaniya cheloveka u stephnykh indoevropetsyev" [Reconstruction of the Plot of a Human Creation among the Steppe Indo-Europeans]. In *Kultury stepnoy Evrazii i ikh vzaimodeystvie s drevnimi tsivilizatsiyami* [Cultures of the Steppe Zone of Eurasia and Their Interaction with Ancient Civilizations], edited by Alekshin, V.A., Bobrovskaya, Ye.V., Dluzhnevskaya, G.V., Kashuba, M.T., Kircho, L.B., Krasnienko, S.V., Nikonorov, V.P., Pshenitsyna, M.N., Rysin, M.B., Savinov, D.G., Sokolova, L.A. and V.Ya. Stegantseva, vol. 2, 35-40. St. Petersburg: Periferiya. (In Russian).
- [BNE 1977] Petrosyan, A. ed., Mirbadaleva, A., Sagitov, M. and A. Kharisov, comps. 1977. *Bashkirskiy narodnyy epos* [Bashkir National Epics]. Moscow: Nauka. (In Russian).
- [BNE 2003] *Bashkirskiy narodnyy epos "Ural-batyr"* [Bashkir Epic Poem "Ural-batyr"]. 2003. Foreword and notes by F.A. Nadrshina. Ufa: Informreklama. (In Russian).
- [BNT 1976] *Bashkirkoe narodnoe tvorchestvo. Epos* [Bashkir Folk Literature: Epics]. 1976. Vol. 1. Foreword by M.M. Sagitov, transl. by G.G. Shafikov. Ufa: Bashkngoizdat. (In Russian).

- [BNT 1989] Bashkirskoe narodnoe tvorchestvo. Volshebnye skazki i skazki o zhivotnykh [Bashkir Folk Literature: Fairy Tales and Animal Tales]. 1989. Vol. 4. Comp. and comm. by N.T. Zaripov and L.G. Barag. Ufa: Bashknigoizdat. (In Russian).
- [BTH 1993] Bašqort tele hüðlege [Dictionary of the Bashkir Language]. 1993. In 2 vols. Moscow: Nauka. (In Russian and Bashkir).
- Bukharova, G.Kh. 2013. "Lingvokulturologicheskaya kharakteristika kubairov" [Linguistic and Cultural Characteristics of Kubair] In Materialy dlya Dose po vklyucheniyu bashkirskikh kubairov tsikla "Ural-batyr" v Spisok shedevrov nematerialnogo naslediya chelovechestva [Materials for the Dossier to Include Bashkir Kubairs of the "Ural-Batyr" Cycle into the List of the Intangible Cultural Heritage of Humanity], edited by Khisamitdinova, F.G. and F.A. Nadrshina, 187-95. Ufa: Institute of History, Language and Literature of Ufa Research Centre of RAS. (In Russian).
- [BXI 1972] Kharisov, A. and B. Bikbay, eds. 1972. Bašqort xaləq izadə. Epos [Bashkir Folk Literature: Epics]. Vol. 1. Ufa: Bashknigoizdat. (In Bashkir).
- [BXI 1981] Kireev, A.N., comp. 1981. Bašqort xaləq izadə. Epos [Bashkir Folk Literature: Epics]. Ufa: Bashkir State University Press. (In Bashkir).
- [BXI 1998] Suleymanov, A.M. and R.F. Ryazapov, comps. 1998. Bašqort xaləq izadə. Epos [Bashkir Folk Literature: Epics]. Vol. 3. Ufa: Kitap. (In Bashkir).
- [BXI 2004] Suleymanov, A.M., Husainova, G.B. and M.Kh. Nadergulov, comps., eds. 2004. Bašqort xaləq izadə [Bashkir Folk Literature]. Vol. 7. Jaðma qissa häm dastandar [Written Kissas and Dastans]. Ufa: Kitap. (In Bashkir).
- Emelyanov, N.V. 1980. Syuzhety yakutskikh olonkho [The Plots of Yakut Olonkho]. Moscow: Nauka. (In Russian).
- Farkhshatov, M.N. 1996. "Rasulev Zaynulla" [Zaynulla Rasulev]. In Bashkirskaya entsiklopediya [Bashkir Encyclopaedia], edited by Shakurov, R.Z., 493. Ufa: Bashkirskaya entsiklopediya. (In Russian).
- Gallyamov, S.A. 2000. "'Ural-batyr' i shumerskiy epos o Gilgameshe" ["Ural-batyr" and Sumerian Epic of Gilgamesh]. In Bashkirskiy folklor [Bashkir Folklore], edited by Suleymanov, A.M. and G.B. Khusainova, vol. 4, 121-53. Ufa: Gilem. (In Russian).
- Gallyamov, S.A. 2007. Bashkodrskaya filosofiya. Estetika [Bashkord Philosophy: Aesthetics]. In 4 vols. Ufa: Kitap. (In Russian).
- Iðükäy menän Moraðəm. Bašərya äðer [Idukay and Muradym: Historical Kubair]. 1994. Comp. by N.T. Zaripov. Ufa: Kitap. (In Bashkir).
- Ilimbetova, A.F. and F.F. Ilimbetov 2011. Kult zhivotnykh v miforitualnoy traditsii bashkir [Animal Worship in the Bashkir Myth-Ritual Tradition]. Ufa: Gilem. (In Russian).
- Khisamitdinova, F.G. 2010. Mifologicheskiy slovar bashkirskogo yazyka [A Mythological Dictionary of the Bashkir Language]. Moscow: Nauka. (In Russian).
- Kondybay, S. 2008. Mifologiya predkazakhov [The Mythology of Pre-Kazakh Peoples]. Part 4. Almaty: 2008. (In Russian).
- Kotov, V.G. 2005. "O skhodstve kosmogonicheskikh mifov u bashkir i ugrov" [On Similarity of Cosmogonic Myths of the Bashkirs and Ugric Peoples]. In Ot drevnosti k novomu vremeni (Problemy istorii i arkheologii) [From Ancient Times to Modern Age (Issues of History and Archaeology)]. Collection of research papers, edited by N.M. Kulbakhtin, is. 7, 92-103. Ufa: Bashkir State University Press. (In Russian).
- Kotov, V.G. 2009. "Bashkirskiy geroicheskiy epos 'Ural-batyr'" [Bashkir Heroic Epic "Ural-batyr"]. In Istoriya bashkirskogo naroda v 7 tomakh [History of the Bashkir People in 7 vols.], edited by Ovsyannikov, V.V., Fedorov, V.K. and F.G. Khisamitdinova, vol. 1, 335-8. Moscow: Nauka. (In Russian).
- Mingazhetdinov, M.Kh. 1971. "Etnogeneticheskie motivy v bashkirskikh skazkakh" [Ethnogenetic Motifs in Bashkir Folk Tales]. In Arkheologiya i etnografiya Bashkirii [Archeology and Ethnography of Bashkiria], edited by Kuzeev, R.G., vol. 4, 301-4. Ufa: Bashknigoizdat. (In Russian).



- Mukhtarov, T.G. 2011. "Konceptsiya dose po vklyucheniuyu traditsiy ispolneniya kubairov tsikla 'Ural-batyr' v spisok nematerialnogo naslediya chelovechestva" [A Concept of the Dossier for the Inclusion of Traditional Performance of the "Ural-batyr" Cycle Kubair into the List of the Intangible Cultural Heritage of Humanity]. In "Ural-batyr" i dukhovnoe nasledie narodov mira ["Ural-batyr" and Spiritual Heritage of the Peoples of the World], edited by Khisamitdinova, F.G., Khubitdinova, N.A., Akhmadeeva, N.V., Khusainova, G.R., Yagafarova, G.N., Yuldybaeva, G.V. and A.M. Khakimyanova, 13–8. Ufa: Institute of History, Language and Literature of Ufa Research Centre of RAS. (In Russian).
- Obydenov, M.F. and K.I. Korepanov. 2005. "Astralno-simvolicheskiy stil v iskusstve kara-abyzskikh plemen" [Astral-Symbolic style in the Art of Kara-Abyz tribes]. In *Ot drevnosti k novomu vremeni (Problemy istorii i arkheologii)* [From Ancient Times to Modern Age (Issues of History and Archaeology)]. Collection of research papers, edited by Kulbakhtin, N.M., is. 7, 81–7. Ufa: Bashkir State University Press. (In Russian).
- Rudenko, S.I. 1960. *Kultura naseleniya Centralnogo Altaya v skifskoe vremya* [The Culture of Central Altai Population in the Scythian Time]. Moscow, Leningrad: Nauka. (In Russian).
- Schafer, E. 1981. *The Golden Peaches of Samarkand: A Study of T'ang Exotics*. Berkeley: University of California Press.
- Shakurova, Sh.R. 2007. *Bashkirskiy narodnyy epos "Ural-Batyr"*. *Arkhivnyy pervoistochnik i ego tekstologicheskiy analiz* [Bashkir Folk Epic "Ural-Batyr". Archive Original and Its Textological Analysis]. Ufa: Gilem. (In Russian).
- Suleymanov, A.M. 2013. "Bashkirskie kubairy i ikh varianty" [Bashkir Kubairs and Their Variants]. In *Materialy dlya Dose po vklyucheniuyu bashkirskikh kubairov tsikla "Ural-batyr" v Spisok shedevrov nematerialnogo naslediya chelovechestva* [Materials for the Dossier to Include Bashkir Kubairs of the "Ural-Batyr" Cycle into the List of the Intangible Cultural Heritage of Humanity], edited by Khisamitdinova, F.G. and F.A. Nadrshina, 199–206. Ufa: Institute of History, Language and Literature of Ufa Research Centre of RAS. (In Russian).
- Sultangareeva, R.A. 2006. *Zhizn cheloveka v obryade* [A Man's Life in the Rites]. Ufa: Gilem. (In Russian).
- Sultangareeva, R.A. 2012. *Başqort säsäñ mäktäbe* [Bashkir School of Storytelling]. Ufa: s.n. (In Bashkir).
- Sultangareeva, R.A. 2013. "Ugroza ischeznoveniya" [Risk of Extinction]. In *Materialy dlya Dose po vklyucheniuyu bashkirskikh kubairov tsikla "Ural-batyr" v Spisok shedevrov nematerialnogo naslediya chelovechestva* [Materials for the Dossier to Include Bashkir Kubairs of the "Ural-Batyr" Cycle into the List of the Intangible Cultural Heritage of Humanity], edited by Khisamitdinova, F.G. and F.A. Nadrshina, 206–12. Ufa: Institute of History, Language and Literature of Ufa Research Centre of RAS. (In Russian).
- Sultangareeva, R.A. 2015. "Melodicheskie osobennosti napevov bashkirskogo eposa 'Ural-batyr'" [Melodious Characteristics of the Chants of the Bashkir "Ural-Batyr" Epic]. In *Traditsionnaya i professionalnaya muzykalnaya kultura Respubliki Bashkortosan* [Traditional and Professional Music Culture of the Republic of Bashkortostan]. Proceedings of the All-Russian scientific and research conference with international participation. 29.10.2015, comp. by N.V. Akhmetzhanova, V.A. Shuranov and F.Kh. Sharifullin, 33–9. Ufa: s.n. (In Russian).
- Yäşägän, ti, batärðar. *Başqort xaläq äkiättäre mäktäbe* [Once upon a Time, There Were Batyrs. Bashkir School of Folk Tales] 2005. Comp. by N.T. Zaripov. Ufa: Kitap. (In Bashkir).
- Yuldybaeva, G.V. 2011. "Ural batär' qobajärä xaläq xäterendä" [Kobair "Ural-batyr" in the Folk Memory]. In *Proceedings of the International Research and Application Conference*, edited by Khisamitdinova, F.G., Khubitdinova, N.A., Akhmadeeva, N.V., Khusainova, G.R., Yagafarova, G.N., Yuldybaeva, G.V. and A.M. Khakimyanova, 105–8. Ufa: Institute of History, Language and Literature of Ufa Research Centre of RAS. (In Russian).
- Yusupov, R.M. 2008. "Paleoantropologiya Juzhnogo Urala i voprosy proiskhozhdeniya bashkir-gaynintsev" [Paleoanthropology of the Southern Urals and Issues the Origin of the Gaina Bashkirs]. In

Bashkiry-gaynintsy Permskogo kraya [The Gaina Bashkirs of the Permsky Krai], edited by Yusupov, R.M., 315-25. Ufa: Gilem. (In Russian).

WATERM

## Teaching Foreign Language: Teaching... Or Fraud?

Sergey Anatoljevich Filatov  
Tollyati, Russia

### Abstract

The article demonstrates impossibility for people without phenomenal abilities or not willing to devote their lives to study foreign languages, i.e. for most people in the world, to master them using modern techniques. This article gets us back to the roots of studying foreign languages, to physiological rules, human memory rules, pedagogical and methodological rules. Violation them resulted in teaching foreign languages becoming probably the greatest fraud in human history.

**Keywords:** basic principles of the foreign language teaching, physiology, human memory model, pedagogical principles, fraud.

### 1. Introduction

Undoubtedly, English is the most popular foreign language in Russia and throughout the world. There is a great deal of English language courses in the vastness of our Motherland. "Golden", "Platinum", "Diamond", "Easy" courses and God knows what else... They promise to teach you English in a month, a couple of weeks and even in a few days! However, I will not criticize any particular method of teaching, neither will I persuade you to buy at a bargain. Here I would like to go back to the origins of teaching foreign languages. I would like to show you the basis for **any** foreign language teaching. Teaching is not a simple thing, it implies several sciences joint together.

I will try to explain all this in such a simple way so that anybody, even not quite competent, would properly understand me. At the end of this article you will find a reference list, so that everybody will be able to read all these books.

### 2. Physiology

It is widely known that mastering any language, including one's native language, was described a hundred years ago by a great Russian physiologist Ivan Petrovich Pavlov in his "Rational Study on The Second and First Signal Systems". This study says that a word, being an element of the second-signal system, causes a corresponding image in the cortex. For example, if we see, hear, write, or pronounce a Russian word *ночь* 'night', our consciousness will create an image of night – wet, cold, dark, etc. It is broadly shown in Figure 1:

Figure 1

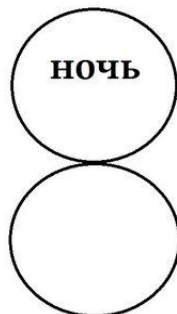

Every such correspondence (word – image) is called a stereotype, and as there are a lot of words in the language, these stereotypes form a system. Such a system is called a **system of dynamic stereotypes**. The word “dynamic” indicates that both the system as a whole and each individual stereotype do not stand still, but rather develop or degrade in time depending on the way we cognize the external world. When we begin to learn a foreign language, its language system overlaps the existing system of dynamic stereotypes. Now, it is two words that will correspond to one image of the first signal system (Figure 2).

Figure 2.

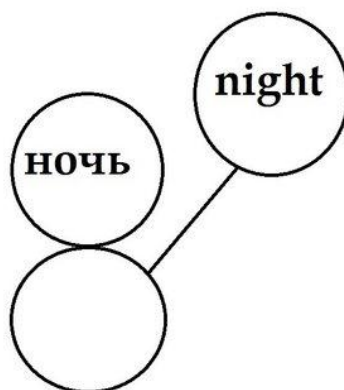

Each image of the first signal system should have several components: audial, visual, hand motor, speech motor, tactile, etc.

Thus, it is 100 years ago that Ivan Petrovich Pavlov stated the following: if at least one of the components is missing in creating new images (i.e. memorizing new words), this image very rapidly destroys.

Almost all modern methods of teaching foreign languages focus on speaking and listening comprehension, i.e. they lack two other speech activities, writing and reading.

Some theoreticians go so far as to abandon writing and replace it by typing; however, it is totally wrong from the point of view of human physiology.

### 3. Model of human memory

In terms of time, man has three kinds of memory, see Figure 3:

Figure 3.

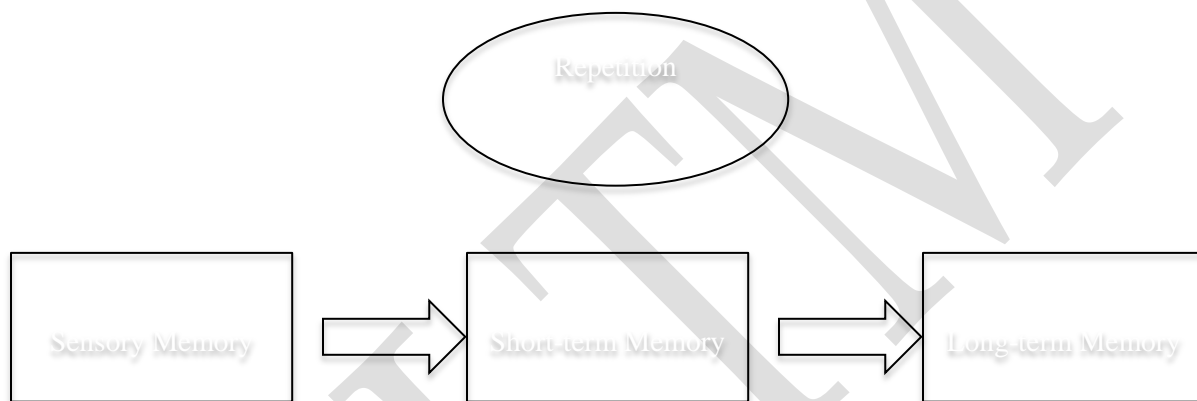

**Sensory memory.** Sensory memory holds information only for a moment. If we **need** the information from sensory memory, it **can** pass to the next stage of memorizing.

**Short-term memory.** Lifetime of short-term memory is measured by seconds. Information can be held here only under of repetition. However, repetition has only mechanic effect on memory and does not give long-term results.

**Long-term memory.** It is long-term memory that holds information for a long time. New information will pass to this stage in case there is a motivation and reflecting on this information, which would arrange and structure the memorized information.

And now let us apply all these data to learning a foreign language. Almost all methods of teaching foreign languages use direct translation (i.e. translation from foreign language into native language) to memorize new words. Let us imagine that there is a sentence “I go home” that should be translated. Let us imagine that I do not know the word “home”, and the only way for me to learn it is to look it up in the dictionary. When I find a corresponding dictionary entry and pass from this word into its meaning, which is described in my native language, my long-term memory throws it away as unnecessary, because this word is still not clear for me; in physiological sense, it has no stereotype – I just do not know it yet.

**At this moment, the word “home” is still a number of meaningless letters for me.** And when I meet the same word in the same text in five minutes, I cannot remember its meaning. I remember that I saw it, because when I was looking for it **I was thinking about how to find it**, but I don’t remember its meaning.

However, let us go back once again and consider this example through the above shown scheme of memory model. So,

1. I saw a word “home” and decided to look it up in the dictionary, i.e. I need this information and my sensory memory let it pass.
2. When I was looking for a necessary dictionary entry, I was holding it in my mind, i.e. it was supported by repetition in my short-term memory.
3. When I found a dictionary entry I needed, my mind shifted completely from the word “home” to its meaning, there is no mental operation in it. Besides, from physiological point of view, there is only one type of speech activity here – reading.

#### 4. Regularity of cognizing external world by a human

This regularity almost always puts an **end** to all “non-translation methods”, “methods of total immersion”, and all preschool and almost all school foreign languages teaching. **First, a picture of well-known past should be made occur in a learner’s cortex, while new information should overlap a picture that already exists in the learner’s cortex.**

Let us think a bit! What remains new and unknown in learning foreign language and what is old and well-known?

**Undoubtedly, it is our native language that is well-known for us, and it is foreign language that is new and yet unknown.**

Any competent teacher of foreign language knows an axiom that **it is impossible to learn any foreign language without knowing one’s native language.**

What knowledge of native language do children kindergartens and primary and [middle schools](#) have?

Almost nothing! There can be no teaching from scratch, it is native language that is a support in teaching foreign language.

#### 5. Pedagogical principles

Few people know what it is. These principles have been formed and polished for centuries, and they are a kind of **pedagogical laws**. People who break the law are called criminals.

##### 5.1. Principle of activity

**Pedagogical principle of activity** immediately puts an end to all methods that suppose teaching foreign languages by affecting the subconscious, because, according to this principle, a learner should be directly involved in the process. **What we speak or write is purely a work of our muscles**, and it is impossible to develop these skills and abilities by affecting the subconscious of the human brain.

##### 5.2. Principle of consistency

I didn’t see a textbook which would comply with this simple principle.

Everybody thinks only about how to throw students in the pool of “total immersion” without knowledge of vocabulary, grammar, phonetics and without experience in translation? It isn’t a teaching from **simple to complicated**? In my opinion, it is actually the other way around.

Everybody is proud that his or her texts are authentic and that his or her teachers are native speakers. But everybody forgot what listening comprehension is and what happens in a person's head when he listens and comprehends the other person's speech

**Listening comprehension is first of all identification of the words that we perceive with the words that we hold in our long-term memory.** It is at the later stage that these words are arranged into sentences and comprehended. First of all, perceived words should be identified. Thus, there is a conclusion: **we should... know these words in order to identify them.** In native language, you know nine words out of ten and can somehow understand the tenth word by intuition. In a foreign language, where this ratio is much lower, intuition can play tricks on you. However, listening comprehension is just one out of four speech activities, and nothing more.

### 5.3. Principle of individuality

This principle puts an end to all the group studies, as **each learner should take such a burden that he is able to take – no more and no less.** But how can this criterion be matched if there are 15 students?

### 5.4. Principle of scientificity

**Now everybody can see that all modern methods are based on nothing.** The person who does not possess extraordinary abilities is not able to memorize a word and begin to use it in speech if he just have hears or seen it some times, because human memory has its own laws which do not subject to our wishes.

### 6. Conclusion

**Now I can assert that teaching foreign languages is nothing more than a kind of fraud.** Teachers take money from people and give them back only hope, a bubble that very soon blows out and bursts once funding ends. If a person is not successful, there is always an explanation: he was a bad student, he wasn't motivated, and he has poor mental abilities. But nobody wants to notice that your own methods do not correspond to anything at all.

Thus, learning foreign languages is neither a game nor a joke. It is a kind of **sport. "sweat and blood" – this is what a foreign language is. There can be no "easy English" courses at all.**

Human speech is very complicated. A human brain should not think what exactly he has to say in a particular situation. It should adjust breathing, as a person can speak only when he or she exhales. Only after a person starts exhaling, the brain gives a command to our vocal cords and sets timbre and volume of a future statement: we can cry or whisper, squeak or speak in a deep voice. Vibrations created by our vocal cords are caught by the exhaled air and enter the mouth cavity. Here we begin to manipulate our speech organs: tongue, lips, and lower jaw. Each word that we know is fixed in neural connections of our cortex. **We cannot change it because this is our physiology. We need to change our physiology in order to change it.**

### References

- Demyanenko, M. Ya., Lazarenko, K. L., & Kislaya, S. V. (1976). *Osnovy obshchey metodiki obucheniya inostrannym yazykam* [Common methodologies of teaching foreign languages]. Kiev: Vyshcha shkola.
- Lapp, D. (1993). *Uluchshaem pamyat – v lyubom vozraste* [Improve memory – at any age]. Moscow: Mir.
- Pavlov, I. P. (1947). *Complete works*. Moscow, Leningrad: the Academy of Sciences of the USSR Press.
- Ushinskiy, K. D. (1946). *Selected works*. Moscow: s.n.

## A Model for Interpreting Author's Intent in the Text of a German Short Story

Tatiana N. Lapchinskaya  
Tyumen State University

### Abstract

The article is dedicated to the issues related to linguistic modelling of the literary text meaning. The model for interpreting author's intent in the text of a German short story is developed on the basis of the model of generation and comprehension of literary texts by analogy with the process of registration and reconstruction of a hologram; it is an algorithm of disclosing author's intent through the sequence of events and the macro-event. Consideration of a series of actions in chronological order and their generalisation to the level of events resulted in identification of two types of the sequence of events in the text – one-component and two-component, which allowed us to find the key event, or macro-event, of the text and reveal author's intent. Our research makes a contribution to the development of algorithmization of the process of studying literary texts and understanding their meanings.

**Keywords:** literary text, German short story, sequence of events, author's intent.

### Introduction

The ambiguous combination of the inner and outer forms of a literary text leads to the need for studying the mechanisms of its semantic interpretation. The subject of such study encompasses not only narrative and ideological uniqueness of a literary text but also the diverse character of embodiment of author's intent, multi-level semantics of the text and the coexistence of explicit and implicit meanings that shape the overall impression of a literary work.

Of particular interest to researchers is the issue of the content capacity of text units of different length, correlation between explicit and implicit components of the text meaning and the mechanisms for retrieving the information implicitly embedded in the text (I.V. Arnold, A.I. Novikov, M.Ya. Dymarsky, N.S. Bolotnova, L.A. Chernyakhovskaya, L.A. Nozdrina, A.F. Papina, V.P. Rudnev, L.V. Sakharny, L.S. Vygotskij, G.Ya. Solganik, G.G. Moskalchuk, K.I. Belousov, and others). The key notions used in the analysis of a literary text are the text generation and the text comprehension. The literary text generation presupposes author's unique, original organisation of the text language and meaning. The literary text comprehension by the reader is not limited to fixing the verbally expressed information on the "surface" of the text – it also assumes disclosure of its encoded deep semantics and author's intent.

### Materials and Methods

In order to find a solution for a rather complicated linguodidactic task of revealing author's intent of the literary text, we find it relevant to develop a model for the process of the literary text generation and comprehension. Needless to say, such a model can be especially explicit when illustrated with the texts of smaller narrative forms due to better possibilities of their integral perception. For our study, we analysed texts of 100 German short stories written and published over the period of 1945-2010. The genre of a German short story appeared in Germany and other German-speaking cultural entities after the Second World War. As indicated by most researchers, its distinctive features are compactness, careful word choice, maximum brevity, ambiguity and coded messages (V. Auffermann, 2004; W. Bellmann, 2004; H. Bender, 2004; H. Böll, 2004; R. Brückner, 2004; K. Doderer, 2004; M. Durzak, 2004; U. Meyer, 2002, etc.).

According to a well-known opinion by Yu.D. Apresyan, modelling is necessary in those fields where the object of research is not directly observable but it is known which input materials the object obtains "at the entry" and which output is produced "at the exit". More than any other research object, a literary text – its essence and author's intent – is similar to a "black box", "at the entry" to which we have only the text as a sequence of words, sentences, paragraphs, but we have to get its verbally unexpressed meaning "at the exit". It is well known that the most important feature of a linguistic model is its ability to be a



functional approximation of the object; it is related to its other properties – to be an idealization of the object, to be able to operate constructs as concepts of ideal objects, as well as its formal and explanatory character. Yu.D. Apresyan explains that any model is always a certain idealization of an object, because, in order to understand the complex real phenomena, one should begin with the study of the simplest and common cases, even if they never occur in pure form, and then move from them to more complex and specialized cases (Apresyan, 1996, pp. 78-91). Following this thesis, a study of the process of comprehending author's intent in the text of a German short story may be started from building a model of literary text generation and comprehension.

According to the classical treatment of the category of the text informativity, based on the semantic concept developed by I.P. Galperin, a literary text is a multi-level informative structure, and its understanding by the reader cannot be reduced to the retrieval of the content-factual information but presupposes disclosure of the encoded content-subtextual and content-conceptual information (Galperin, 2006, pp. 39-49). Our study of I.P. Galperin's semantic concept contributed to identification of elements for the model of literary text generation and comprehension and suggested the idea of using the category of informativity as a construct for the model of generation and comprehension of a literary text.

We suppose that a figurative analogy for the model of generation and comprehension of literary texts can be found in the optical model of hologram registration and reconstruction, as these processes are functionally and structurally similar to each other.

We would like to describe briefly the process of hologram registration and reconstruction as a physical phenomenon. The word "hologram" comes from the Greek words *holos* (whole, entire), and *graphos* (written, writing). Holography, which emerged as a field of optical science and engineering in the middle of the 20th century, allows creating a complete visual image of a physical object – a hologram, which is widely used in physics and other spheres for pattern recognition and encoding of information. The essence of optical holography can be described as follows: the reference and object beams (waves) interfere with each other, creating a complicated "picture" of multiple fine lines forming intricate patterns on the recording medium. This picture is a recorded hologram storing information about the object; when read, it allows seeing a detailed 3D image – a holographic "blueprint" for the physical object.

The hologram creation process includes two stages: registration (or recording) and reconstruction, schematically presented in Fig. 1 and 2. Let us describe each of these stages – hologram registration and reconstruction – in more detail.

At the stage of registration (Fig. 1), a laser beam is first directed to a beam splitter, as a result of which one part of the beam goes further and another is spread and directed onto the object. The part of the beam that passes the beam-splitting mirror is called the reference beam, and another, which is reflected from the object, – the object beam; they must have both the same frequency. Interference of these two beams produces a resultant wave, in the field of which a photographic plate is placed to record the hologram.

At the reconstruction stage (Fig. 2), a photographic plate with the recorded hologram is to be illuminated with a laser reference beam identical to the one used to record the hologram. This produces a beam identical to the object beam originally scattered onto the photographic plate, i.e. the photographic plate with the recorded hologram transforms the reference beam into a facsimile of the object beam. As a result, we can see the light beam that is identical to that reflected from the recorded object, which, in fact, allows observing the "blueprint" of the registered physical object (Pirozhnikov 1983, pp. 102-108)

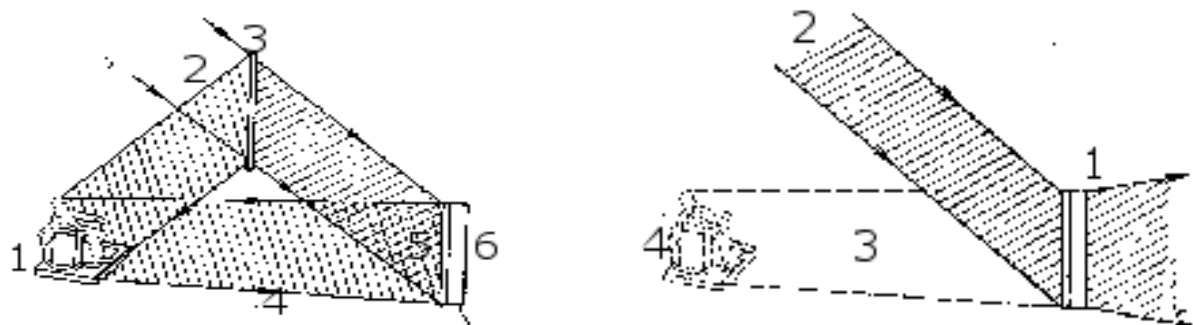

Fig. 1.

**Hologram registration – literary text generation**

- 1 – hologram object – *content-subtextual information (CSI)*;
- 2 – reference beam – *linguistic organisation of the text*;
- 3 – beam-splitting mirror – *semantic organisation of the text*;
- 4 – object beam – *encoding of content-subtextual information (CSI)*;
- 5 – interference – *content-conceptual information (CCI)*;
- 6 – hologram (pattern on a screen) – *literary text (CFI, CSI, CCI)*.

**Fig. 2. Hologram reconstruction – literary text comprehension**

- 1 – hologram (pattern on a screen) – *literary text (CFI, CSI, CCI)*;
- 2 – a beam that is similar to the reference one – *analysis of the linguistic organisation of the text*;
- 3 – reconstructed object beam – *reconstruction of the content-subtextual information (CSI)*;
- 4 – reconstructed image of the object – *content-subtextual information (CSI)*

Like in the process of hologram registration resulting in recording a picture of numerous dots and patterns, any literary work contains a linear pattern recorded in the text. Individual words and their combinations within the text set a unique author's pattern of the text.

At the stage of text generation, corresponding to the stage of hologram registration, components of these two models can be compared as follows:

- 1) the content-subtextual information corresponds to the object to be registered;
- 2) linguistic organisation of the text is similar to the reference beam;
- 3) the role of the beam-splitting mirror is played by semantic organisation of the text, which is some kind of filter dividing explicit and implicit meanings of the text;
- 4) encoding of the content-subtextual information corresponds to the object beam;
- 5) interference or the resultant wave can be compared with the content-factual, content-subtextual and content-conceptual information in the text;
- 6) the text is some kind of hologram.

At the stage of text comprehension, corresponding to the stage of hologram reconstruction:

- 1) the text is the registered hologram;
- 2) analysis of the linguistic organisation of the text corresponds to the beam that is similar to the reference one;
- 3) reconstruction the content-subtextual information corresponds to the reconstructed object beam;
- 4) the reconstructed content-subtextual information corresponds to the reconstructed image of the registered object.

In our example the key component of the model of literary text generation and comprehension (the object to be registered) is the content-subtextual information that should be "fully retrieved" as a "detailed image" in the process of the text comprehension. The explanatory character of this model is in its ability to reflect not only the comprehension stage but also the text generation stage, thus providing an opportunity to simulate the entire interpretation process from comprehension to generation.

A formal model, as a rule, can be used to interpret different subject areas. In terminology of Yu.D. Apresyan, the model of literary text generation and comprehension is a "common case" and the first step towards understanding some complex phenomena on the way to considering a "specialized case" of the process of revealing author's intent in a literary text of certain genre – a German short story in our study. The first part of the model of literary text generation and comprehension reflects the process of the text creation by the author, and it is related only to the author. The process of the literary text comprehension by the reader is reflected by the second part of the model. The process of interpreting author's intent involves the analysis of linguistic and semantic organisation of the text and presupposes "decoding" of its deep semantics. Modelling of the process of literary text comprehension involves modelling of means and techniques of analysing its content-factual and content-subtextual information aimed at forming the content-conceptual information.

The clue to retrieving the content-subtextual and content-conceptual information should be searched, first of all, in specific properties of a particular literary genre. A German short story as a genre of fiction has a specific structure of content. Based on analysis of such elements of the content of a German short story as narrative events and actions, characters who are experiencing these events and take these actions, time duration and the temporal sequence of these events and actions, space and place as the world around the characters and an arena for the events and actions (Hermes, 1997, p. 7), we determined that the central decisive element of the content of any German short story is the event, because all the other elements are organized around the event and are determined by the event. In such context, the event is a much wider notion than merely an action – it performs the function of generalization, summarising a series of actions that, as a rule, correlate with one of the elements of the text content. Consideration of actions in chronological order and their generalisation to the level of events allows identifying a so-called sequence of events in the text. In our opinion, the sequence of events is related to the content-factual information.

We consider that identification of the "macro-event" – the key event of the text around which the entire sequence of events is organised – can be seen as a technique for "retrieving" the content-subtextual and content-conceptual information of a German short story. The macro-event as a core element of the text passes through all components of the sequence of events and correlates with the content-subtextual information, which is not verbally expressed. The procedure of the macro-event identification consists of two stages: first, we need to build the sequence of events in the text; second – to identify the macro-event. We would like to clarify that, speaking about building of the sequence of events, we mean the following operations: to divide the text into semantically relevant and coherent segments, with the start of each subsequent segment coinciding the change of the scene of action, beginning of a new time period, appearance of new characters or a change of action; to entitle each segment and to present the segment titles consistently in the form of the sequence of events. At the second stage, we need to identify the "macro-event" – the key event of the text around which the entire sequence of events is organised. Analysis of the sequence of events, reflecting the content-factual information, and the macro-event, reflecting the content-subtextual information, allows structuring the process of interpretation, or disclosure of the author's intent.

Let us consider H. Böll's short story entitled "Monolog eines Kellners" (Monologue of a Waiter) as an example of building the sequence of events and identifying the macro-event. Here is a brief plot summary of the short story: the main hero, who works as a waiter, begins his monologue from the description of a Christmas Eve dinner in the restaurant of an expensive hotel. After work he goes to his room and orders his Christmas meal – some pea soup, reminding him of his mother, which is symbolic for the Christmas celebration. Suddenly a boy, looking for a partner for playing marbles, comes to his room. He needs a pit for the play, and the waiter makes one on the floor of the room at boy's request. The boy's mother spends the Christmas night in the bar, leaving her son alone. Coming back early in the morning, she breaks her leg, tripping over the hole in the floor. The main hero is fired.

At the first stage, we built a sequence of events: "1. Dinner – 2. Feierabend – 3. Bengel – 4. Spiel – 5. Kündigung".

At the second stage, we identified the "macro-event", including and summarising the maximum amount of events - "The Christmas Eve" (Der Heilige Abend). It is a wonderful clue for decoding author's intent. The hidden meaning of the text is revealed through the fact that one of the main attributes of Christmas celebrations - Weihnachtsbescherung (giving and receiving presents) - traditionally occurs on the Christmas Eve, therefore the author intentionally selects this period of action, providing all the characters of the story with the presents they deserve. The boy and the waiter become Christmas gifts for each other, since both of them were to spend the Christmas Eve alone. The boy is especially happy because the waiter becomes his playing partner. The boy's mother, who leaves her son alone to spend her time in the bar, also gets the Christmas present she deserves. The macro-event "Der Heilige Abend" reflects multidimensionality of the story narrative space, as it not only expresses temporal meanings but also presupposes certain actions connected with such celebration, which are taken or should be taken by the story characters.

Let us consider another example - "Die Tochter" (The Daughter) by P. Bichsel: in this short story, the scene of action does not change, new characters do not appear, duration of the action is limited to a few evening hours, therefore it cannot be divided into segments - it is some kind of a continuous single piece. Only one component of its content is reflected in the title of the short story, referring to one of its characters.

In order to identify the macro-event in the text that cannot be divided into segments, in our opinion, it is necessary to consistently consider the actions of a constant "set" of characters at a specific location in a fairly limited period of time and to generalize them to the level of the event. Here is a brief plot summary of the short story: every evening the parents are waiting for their grown-up daughter working in the city. For this reason, they take their dinner one hour later. While they are waiting for their daughter, they talk about her, discussing such themes as, for example, her resemblance to husband's sister, her fashionable clothes and her life in the city, and try to predict her near future (she will marry and rent a room in the city). The daughter is present only in phrases and thoughts of her parents but never appears in person. The last sentence of the text tells that her mother hears the sound of the arriving train and sets the table for dinner.

Everything happening can be generalized in one event of "Waiting for the daughter" (Warten auf die Tochter). The event of "Waiting for the daughter" reflects the prolonged waiting as the main action of the text, indicating the presence of the object of waiting and those waiting. Only the place of action is not evident in the formulation of the only event of the text. The event of "Waiting for the daughter", generalising the sequence of actions taken by the story characters, is the macro-event of the text. The macro-event "Waiting for the daughter" reflects the state of the parents, whose whole life is organised in compliance with daughter's life and actually consists only of waiting for the daughter. The fact that the parents are constantly taking about their daughter indicate their obsession with her and absence of any other interests.

### Results

The above examples demonstrate the stages of identifying the macro-event in the text of a short story and its semantic function in the structure of the text content and meaning, as well as in revealing author's intent. The sequence of events is organised around the macro-event, which is projected to all components of the sequence and brings the real significance of all events onto the surface of the text. As a result of our analysis, we found two types of semantic organization or the structure of the text meaning: one-component - with one component in the sequence of events, and multi-component - with two or more components in the sequence of events. The macro-event in one-component texts was identified through generalisation of actions of the characters. Analysis of the sequence of events, reflecting the content-factual information, and the macro-event, reflecting the content-subtextual information, allowed us to find a new approach to interpretation of the meaning of text, i.e. disclosure of author's intent. We used this technique to analyse 100 German short stories. For each of them we considered actions in

chronological order and performed their generalisation to the level of events. We were able to divide 73 texts out of 100 into two or more segments, thus revealing multi-component structures of their meanings. We built sequences of events for those texts and identified their macro-events. We revealed one-component structure of meaning in 27 analysed texts.

#### Discussion

Components of the model for interpreting author's intent in the text of a German short story, as a "specialized case" of the process of revealing author's intent in a literary text, can be projected to the elements of the model of generation and comprehension of a literary text as a "common case" and the first step to understanding such complicated phenomenon as revealing the content-subtextual and content-conceptual information in a literary text. In the table below you can see correlation between the models, with elements of the model for interpreting author's intent in the text of a German short story highlighted in bold type.

Table 1

Correlation between components of the model of literary text generation and comprehension and the model for interpreting author's intent in the text of a German short story

<i>Hologram registration</i>	<i>Text generation</i>
Reference beam	Linguistic organisation of the text
Beam-splitting mirror	Semantic organisation of the text
Object beam	Encoding of content-subtextual information - <b>Encoding of the macro-event</b>
Interference	Content-conceptual information - <b>Author's intent</b>
Hologram object	Content-subtextual information - <b>Macro-event</b>
Hologram (pattern for retrieving)	Literary text ( <b>sequences of events, macro-event, author's intent</b> ).
<i>Hologram reconstruction</i>	<i>Text comprehension</i>
Hologram	Literary text ( <b>sequences of events, macro-event, author's intent</b> ).
A beam that is similar to the reference one	Analysis of the text linguistic organisation
Reconstructed object beam	Reconstruction of content-subtextual information - <b>Macro-event identification</b>
Reconstructed image of an object	Content-subtextual information - <b>Macro-event</b>

As we can see in the table, the elements of the model for interpreting author's intent in the text of a German short story (event, sequence of events, macro-event, author's intent) fit into the model of generation and comprehension of literary texts. The explanatory character of the model for interpreting author's intent in the text of a German short story is in its ability to reveal the content-subtextual and content-conceptual information that is present in the German short story but is not expressed verbally.

#### References

1. Apresyan Yu.D. *Idei i metody sovremennoj strukturoj lingvistiki (Ideas and Methods of Contemporary Structural Linguistics)*. Moscow, 1996, 305 p.
2. Auffermann V. *Vorwort - Spione der Gegenwart zu Beste deutsche Erzähler 2001. Theorie der Kurzgeschichte*. Stuttgart, 2004, 160 p.
3. Galperin I.R. *Tekst kak ob"ekt lingvisticheskogo issledovanija (Text as an Object of Linguistic Research)*. Moscow, 2006, 144 p.
4. Pirozhnikov L.B. *Chto takoe golografiya? (What is Holography?)*. Moscow, 1983, 102-108 p.

5. Bellmann W. Interpretationen Klassische deutsche Kurzgeschichten. Stuttgart: Philipp Reclam jun., 2004, 309 p.
6. Bender H. Ortsbestimmung der Kurzgeschichte. *Theorie der Kurzgeschichte*. Stuttgart, 2004, 160 p.
7. Böll H. Interview mit H. Böll. *Theorie der Kurzgeschichte*. Stuttgart, 2004, 160 p.
8. Brückner R. Training Aufsatz Analyse und Interpretation literarischer Texte. Stuttgart/Düsseldorf/Leipzig, 1997, 128 p.
9. Doderer K. Die Kurzgeschichte in Deutschland. *Theorie der Kurzgeschichte*. Stuttgart, 2004, 160 p.
10. Durzak M. Die deutsche Kurzgeschichte der Gegenwart. *Theorie der Kurzgeschichte*. Stuttgart, 2004, 160 p.
11. Hermes E. Training Analyse und Interpretation erzählender Prosa. Stuttgart/München/Düsseldorf/Leipzig, 1995, 125 p.
12. Meyer U. Kleine literarische Formen in Einzeldarstellungen. Stuttgart, 2002, 278 p.

## Language And Social Structure

Olga B. Istomina

Irkutsk State University, Russia

### Abstract

The relevance of the study is conditioned by the intensification of language contacts, as well as the development and active use of the majority international languages, that significantly narrows the scope of the ethno-national languages and contributes to their devaluation. However, despite of the universalization the actions aimed at the preservation and development of ethnic cultures get more intensive. Dialectically contradictory trends of modern verbal space are caused by the influence of the homogenization of cultural types and ethnic consciousness increase. The purpose of the article is to establish the dependence between the communicative competence and social differentiation of society in the conditions of growing trends of globalization and the spread of assimilation processes. The leading method of this problem study is sociological survey of bilingual population in the areas with a high level of ethnic composition mosaicity (the case of the Siberian region). The sample volume is 1006 people. The survey revealed that at the present stage the formation and development of contacts in the multicultural region is determined by the objective conditions of the social environment, as well as the subjective personal characteristics of linguocultural interaction participants. Communicative competence is influenced by such factors as: national and demographic characteristics, population density, dispersal of ethnic groups in the region, presence of subnational entities, correlation of urban and rural groups, as well as age, socio-status, vocational and educational differentiation and speech orientation of communicants. Urban lifestyle, violation of generations linkage, language pragmatic functions predominance in the minds of its speakers and high socio-professional activity form "social habit" of using a convenient language of an ethnic majority in all the spheres of life, that leads to the spread of receptive, incomplete, highly ineffective forms of language contacts. The information can be applied in the management and politics in order to minimize conflicts in the field of international and interethnic relations and in order to preserve the multiethnic cultural image of a region and state. The authoring are applicable in the field of national and cultural, educational and linguoecological activities to address the ethno-national and ethno-linguistic issues.

**Keywords:** bilingualism, language competence, cross-cultural contacts, speech orientations, spheres of communication, language behavior, language situation.

**Introduction.** Intercultural communication in Irkutsk Oblast nowadays provides diversity of cross-cultural contacts, including exogenous, with various structure. A bright example of bilingual communication in the Baikal region is the interaction between Russian and Buryat, Russian and Tatar, Russian and Polish, Russian and Evenk, due to the contacts of local ethnic cultures on the territory.

The difficulty of preserving and developing ethno-national languages in the contemporary situation of the Russian language dominance is increasing as a result of transformation of the definition of a "native language". Drawing on the empirical data of regional research, we note the extension of the functional basis in the content of the term, overemphasizing the operational possibilities of language in contrast to the philosophical basis of the notion. Since the importance of the functional criteria in the twenty first century is undeniable, the identification of language load level for the analysis of language behavior becomes paramount (Istomina, 2009).

Bilingualism as a special complex quality of neuro-linguistic activity of a human being depends on the peculiarities of the social structures of his community, the accepted forms of relations and interethnic contacts. Social structure as a historically developed form of social relations determines socio-cultural

models of behavior, roles, norms, rules of interethnic interactions. This structure creates social qualities, which combine individual consciousness with the consciousness of a certain ethnic group. The socio-territorial substructure (the type of interregional relations), gender substructure (sex ratio), age substructure (age ratio), educational substructure (educational status ratio), socio-professional substructure (types of jobs), confessional (religious beliefs) substructure – all of them characterize the socio-cultural conditions of interrelations and cooperation of ethnic groups in certain territories. Lots of elements of social structure influence the functioning of bilingualism. Taken together, the above factors define the peculiarities of discourse, language behavior and orientations.

**Materials and methods.** The methodological basis of the research was dialectical method, general scientific approaches and learning styles applicable to the subject of the language situation: historical, systemic, comparative, structural and functional analysis. In addition, such methods as synthesis, typologization, as well as some means of sociological research (questionnaire and expert surveys, semi-formalized and non-formalized interviews, etc.).

The data of federal, regional state statistics, the All-Union and All-Russia population census 1959, 1979, 1989, 2002, 2010., reports of sociological research hold by the Levada Center, information of the state archives of the Irkutsk Region, Ust-Ordynsky Buryatsky Autonomous District (since 1st January 2008 Ust-Ordynsky Buryatsky district), information references of administrations, regional and district departments of board of education, the press Committee of the Irkutsk region, information from the Ministry of education of the Irkutsk region, newspaper and magazine publications and materials from the Internet and the personal observations of the author served as informational basis for the research.

Basing on the empirical data of the author's research (sociological survey of bilingual population "Language behavior: competence and orientations", 1006 participants, 2012–2016), let us consider the levels of coexistence of the Russian and Buryat languages, taking into account the impacts of the determining factors.

The authors used a multi-stage sample comprising national, educational and professional groups of respondents. The purpose of the research was to determine the degree of minority languages and Russian language proficiency among the population of the Cisbaikal region, taking into account the socio-territorial, age, educational, occupational differentiation (Istomina, 2012).

**Discussions.** There is a few sciences that deal with the issues of language contacts. The variability of research approaches makes bilingualism general scientific and multifaceted problem. The linguistic approach, which is aimed at bilingual discourse characteristics identification by means of comparative analysis has become the most widely spread among all the aspects of language contacts study which are well-known in domestic and foreign science. In addition, language contacts are studied by ethnographers, lawyers, teachers, psychologists and, of course, by philosophers, who analyze and synthesize all the information received for the development of a stable ethno-positional identification of society.

Under present-day conditions of society ideology standardization the problem of ethno-identification is becoming increasingly important. The processes of ethno-linguistic identification are associated with communication and social behavior principles selection, ethnic interactions types. The features of ethno-national character of ethnic identity were studied by such researches as A. O. Boronoeva, N. A. Narochnitskaya, Yu. E. Prokhorova, L. V. Savinova, A. Yu. Hamnaeva. The contribution of language to a person identification process determines its place in the national and ethno-linguistic political relations. The current state of ethno-linguistic policy is analyzed in the academic papers of S. E. Rybakov, R. H. Simonian, Zh. T. Toshchenko and V. N. Yarskaya. Attitude to language, its status, levels of competence



and sphere of functional application are directly dependent on national policy systems in a region and state. In the modern multi-cultural environment language policy as a tool for managing international and interethnic relations acquires the functions of control and regulation of social relations.

Link between ethnic and linguistic identification and specific forms of social behavior are described by L. Bloomfield, L. N. Gumilyov, E. Fromm. The special role of lacunae, individual manifestations of culture as a means of expressing dispositional subjects of culture and the conditions of deeper objective self-assessment of the subjects data are described in the works of E. Haugen, J. Habermas and A. Schyutz. The need for cultural mirror to identify the properties of a person's worldview, including the language one was identified in the works of S. Goddard, C. H. Cooley and L. V. Shcherba.

In modern conditions language is understood as an indicator by means of which we can reveal many layers of social life. Bilingualism is indispensable attribute of the social life of a multi-ethnic region. The problems of formation of high-grade deep bilingual competencies are described by L. Leopold, J. Ronge, M. N. Pevzner and A. G. Shirin. The current situation about language contact between interethnic groups in the modern society, backed by the policy of cooperation and interaction between the peoples, indicates a need for the further theoretical understanding of the problem from the standpoint of an integrated approach based on actual linguistic, philosophical, sociological, psychological and pedagogical aspects. In the situation of ethnic and cultural pluralism, social importance of bilingualism is incontestable.

As is evident from the above works review, the scientific literature covers many aspects of linguistic contacts in modern society, especially in linguistic aspect. At the same time a number of important aspects of this complex problem were not quite fully understood by society and philosophers. Among them are the essence and basic forms of language contact in modern Russian society, in its regional entities. The basic tendencies of contacts development in the context of growing globalization remain poorly studied. The nature and characteristics of linguistic contacts in regional multi-ethnic environment also need to be analyzed. The influence of social structure on the dynamics of verbal behavior remains understudied. This determined the subject of the research, its purpose, objectives and methods.

## Results.

**Socio-territorial substructure of bilingualism.** The differences based on socio-territorial affiliation in the system of formed bilingual competences influence the choice of communication instrument. For example, the urban environment significantly decreases the degree of intensity of cross-national linguistic contacts providing information channels for monolingual discourse. The low index of national diversity in urban settlements determines the predominance of the language of ethnic majority, narrowing the "living space" for ethno-national languages, especially in regulated spheres. As in most educational establishments instruction and training is performed in Russian, and other ethnic languages are not even included in the curriculum, the language of ethnic majority (Russian) becomes the only instrument of spoken communication, and the level of written language skills of ethno-national (non-Russian) languages in urban school students decreases considerably.

The high proportion of the Russian language in the structure of regional language behavior affects the levels of ethno-linguistic competences. In the self-estimation of reading abilities in the Buryat language, 9.0% of urban Buryats and 31.4% of rural respondents state fluent reading, 7.0% and 30.3% respectively register reading with difficulty; 7.0% and 23.2% write easily, while 8.0% and 26.5% write with difficulty. Certainly, the subjectivity of evaluation has its bearing on the results, which may be significantly corrected at objective consideration. The self-evaluation of listening/speaking skills in the national language demonstrates higher indicators: "understand easily" is marked by 71.1% urban Buryats and 91.9% rural Buryats, "understand with difficulty" – 9.0% and 7.9%, "speak fluently" – 62.7% and 80.3%,

“speak with difficulty” – 16.0% and 15.5%, respectively (Istomina, 2012). The levels of writing and reading skills being so low demonstrates that only the reproductive and receptive types of bilingualism are common in the region. The level of language competence is inseparably connected with the degree of functional load of this language, thus, decreasing language competence reflects the decrease of functional load and declining actual use of a language.

The evident shift of ethnic languages in the region into the spheres of conversational use objectively decreases the need for writing skills. If a language is spoken only in certain socio-linguistic spheres, writing and reading skills are gradually depreciated (Istomina, 2011). In the modern society, as a result of technological development, personal correspondence loses its position of an independent type of language interaction; writing in the ethnic language of a group becomes unnecessary.

The language behavior of Buryats living in the urban environment is characterized by variable, alternate usage of the ethnic and Russian languages; in family communication with children the Buryat language is used in 33% of situations, with grown-ups – 63%, with friends – 21%, at work – 4%. The rural respondents use their native language more often: in family communication with children – 40.2%, with grown-ups – 42.2%, with friends – 53.1%, at work – 18.8%. Such language situations as “reading”, “watching TV”, “writing”, “appeals to authorities” are mediated only with the majority language (Istomina, 2012). To a greater extent, bilingual communications are characteristic of rural territories, in which traditional features of culture are preserved.

The social characteristics of linguistic identity based on territorial differentiations determine the forms of language behavior and the choice of communication instrument in different spheres of life. The socio-psychological context of communication accepted in a certain settlement is the basis for building an appropriate model of linguistic contacts.

**Gender substructure of bilingualism.** Gender as social sex, i.e. the set of socio-psychological characteristics of linguistic identity, has a significant effect on language behavior. Gender identification determines the peculiarities of social roles and the level of communicative competence. Differences in sex are reflected in the structure of linguistic identity that includes verbal, semantic, cognitive, pragmatic levels (from elementary production of speech to perception and evaluation of speech operations). On account of the pragmatic level, which provides interaction with motivation and goal, it is evident that the choice of language means is dependent on the gender (social sex) of communicants.

In the theory of F. Mounter and O. Jespersen (1924), femininity of speech is reflected in more conservative usage of language, which is especially characteristic of emigrants. O. Jespersen notes greater willingness to learn a new language in men and explains it by their need for intensive work activity. And on the contrary, women focus on referential, intra-ethnic, family household communication, which determines the tendencies to monolingualism of their speech on the basis of ethnic language. However, in the modern world, the equality of social rights and guarantees reflects on language competences. The increasing social activity of women is projected on leveling the differences in language behavior of social genders. The knowledge of three and more languages (Russian, Buryat, one or two European ones) is mentioned by 28.2% men and 30.2% women, the knowledge of Russian only by 2.3% and 2.7%, respectively. Nevertheless, gender differences appear in the determination of functional priority of language: among men, the Buryat language is used in 2.3% cases, among women – in 5.9% (Istomina, 2012).

The results of the research give reason to believe that gender stratification, though to a lower degree than before, is able to exert pressure on language orientations of communicants. Smoothing the differences in

rights between social genders and increasing social role of women in the society are able to change language competence and transform language preferences among social groups.

**Age substructure of bilingualism.** Bilingualism in the aspect of age characteristics allows to trace the stages in the history of bilingual education development, reflects the tendencies of national policy in the region and the whole country. In the end of the 1990s, the so-called “national component” was introduced into the school curriculum; the primary and secondary schools in ethnic settlements (mostly rural) started teaching the Buryat, Polish, Tatar, Evenk, Tofalar languages as separate subjects, which allowed younger people to be involved into bilingual relationships. Yet, the largest percentage of fluent language use (including all four language skills) is noted among the older age group, for whom the native language remains an effective means of communication. A direct relation between age and language competence is traced: the older the respondent, the higher his level of ethnic language. The dichotomous dependence between age and language behavior is confirmed by the choice of language in official and personal communication: older people use their native language more often, demonstrating the qualities of bilingualism. The spheres of broader co-functioning of languages are, again, household, family, referential communication. The co-functioning of the Russian and Buryat languages in household communication with children is characteristic of 20.4% of the respondents aged 14–20, 31.6% of those aged 21–40, 51.4% aged 41–60, 50.0% aged 61–80 (Istomina, 2012). In the modern conditions, when the link between generations is broken and children live separately from their parents, the pressure of the “prestigious”, convenient, majority language can become fatal for preserving and functioning of the ethnic language even in family-household communication. Similar processes and phenomena occur in many other ethno-national languages of the multicultural region and country as a whole.

**Educational substructure of bilingualism.** Among other factors, the educational status of an individual has a considerable influence on language behavior expressed in the level of language competence, in the functional priority/secondariness of language, in attitude to it, understanding its social roles, language preferences in typical spheres of communication.

The spoken form of language is more available for all educational groups, while the written form, which requires additional systemic intellectual efforts, depends on educational status. As A. A. Potebnya (1862) puts it, personal development correlates with national development, strengthening national identity. Nevertheless, the knowledge of a language does not imply the demand for it in everyday life; knowing a language does not mean using it. The respondents with primary education choose the Russian language as the main means of communication in 63.9% cases and those with higher education – in 97.7%. Active involvement in the official and business sphere, professional work, social activity determines a greater need for the majority language; it reduces the frequency of switching linguistic codes, imposing Russian in the situations when the ethno-national language could and must be used. The results of our research prove that the higher the education of a person is, the more frequently he uses Russian as the instrument of communication, the lower the proportion of native language is in his discourse.

In case of several coexisting languages on one territory, a bilingual user, entering various communicative situations, always has to choose a language as the instrument of communication. As bilingualism in the system of social relations requires a choice of a language, determining its role and status, the term “preferred language” is introduced. After analyzing all objective and subjective factors determining a linguistic situation and language behavior of communicants, a language is selected, which is appropriate and suitable at this very moment for achieving the goal of communication. More often, the preferred language appears to be oriented to the social environment aiming to solve a large number of communicative tasks.

High educational status as a professional and social resource forms language behavior relevant to communicative preferences of a social group. The research results confirm the dependence of language orientations on the educational differentiation of population: the increase of this status corresponds to the decrease in the activity of language contacts on the basis of the Russian and ethnic languages, and increases the contacts between cross-national and European languages.

**Socio-professional substructure of bilingualism.** Social position and professional status also appear to be important factors influencing the process of determining the preferred language. Different groups of bilingual society have different level of language use. Five social groups participated in the research: students/school students, professional employees, non-professional employees, pensioners, unemployed people. The distribution of functional load depends on the level of involvement into social life: among students, the Russian language is 100% preferable, among non-professional employees – 97.5%, among professional employees – 97.1%, among pensioners – 77.6% , among unemployed – 31.5% (Istomina, 2012).

Active use of a language in the professional sphere over a long period of time forms a social habit of transferring the language preferences from this sphere to other levels of communication, including referential communication. Absence of affiliation with a professional group, quitting participation in official socio-industrial relations allows a person to choose the model of language behavior basing on his personal attitudes. The determining criteria in the choice of language are individual preferences of the speaker and socio-ethnic characteristics of his collocutor, which explains the need for bilingual communications in the social groups living in national settlements. The dependence of language behavior on the socio-professional structure of the society is expressed in the tendency towards increasing the importance of bilingual competences and their realization in actual discourse in case of decreased professional activity.

**Confessional substructure of bilingualism.** Religion as a worldview based on belief in a higher transcendent power, in the supernatural, is an important regulator of social relations in the modern polymentality of society. As religion is understood as “spiritual support”, it affects the content and expression of modern cultures, character of their interactions; it is able to promote preservation of tradition in culture. Performing rituals suggests the knowledge of language of a certain cult, which is why preservation of traditional confessions of ethnic groups on the territory of the region promotes preservation of these ethnic languages.

Over the last twenty years, we have marked strengthening tendencies of increasing attention to religious and confessional organizations and groups: in 1990, 35 of them were registered in the region, in 1999 more than 250, nowadays there are more than 300 religious organizations, 283 of them are officially registered in the Department of Federal Registration Service. They relate to 21 confessions, dominating among them are: Orthodoxy – 75%, Islam – 6%, Protestantism – 5%, Buddhism – 2.5%, Judaism – 1.5%, Catholicism – 1%, shamanism – 0.8% (Istomina, 2012). Leaders of religious organizations are members of the Public Chamber (formed in 2007) as well as the Interconfessional Council of the Region, and they participate in the work of councils and committees on humanitarian and social issues.

The analysis of social structure exemplified by the regional type of cross-ethnic interactions proves that language behavior in many cases derives from social behavior of individuals. It is important to remember that the factors forming situational social settings and affecting the choice of language include, among others, the needs of speakers, their relations and roles, complementarity, social distance, etc. Language preference is affected by a number of objective and subjective reasons, the important one among them being the factor of addressee. If the addressee is monolingual, the choice of language is predetermined independently of the level of this language knowledge in the bilingual speaker and his language

preferences. If the addressee is bilingual, the choice of language depends on the communicants' speech preferences, which, in turn, are modified by the language competence of both participants, on the character of situation (official/unofficial), and so on. Language preference can express group norms in relation to the contacting languages, their social status, their prestige, and individual attitude of a bilingual person to the languages he knows.

The number of communicative spheres of language functioning, as well as the set of its functions, is determined by extra-linguistic social factors. It is evident that opportunities for intensive development are given to the language which performs the majority of social functions, in other words, to the preferred one. The decreasing frequency of bicultural communications in the official and business spheres among urban and rural inhabitants, the predominance of Russian monolingualism strengthen the cultural stereotype of the "prestigious" Russian language performing the role of macro-mediator. These stereotypes are expressed in various forms of ethnic unification process, in changing the position of lingual identity. The differentiation of languages according to the scope of their use, which is reflected in the discourse of urban and rural people, naturally transforms the understanding of the "native language" idea. There is a steady decrease in the number of people considering the language of their nationality to be their native language. Language assimilation among ethnic groups in the Russian Federation continues, and under the influence of universalization, its speed is increasing. In accordance with the report on "Prevalence in knowledge of languages in Russian federal entities", only 28.7% Buryats, 8.6% Evenks, 31.7% Tatar, 11.9% Tofalars, 47.2% Yakuts living in Irkutsk Oblast know the language of their ethnic group to varying degrees. It is evident that the importance of ethno-national languages in the social life of people is gradually decreasing. This is the reason for including the question "What language do you consider native?" into the questionnaire surveying the regional features of bilingualism. It reveals not only language preferences but also the main aspects of national policy.

The Buryat language is considered native by 70.7% respondents of this ethnic group, and for 29.3% respondents this function is performed by the Russian language. The information received during the research correlates to the results of the 2002 and 2010 All-Russian Population Censuses. If a language is not known by a communicant and is not the instrument of communication in any sphere of life, it cannot be the key to self-identification or the conductor to the ethno-national culture. The result of this situation is ethnic indifference.

The choice of native language is influenced by the same factors, among which: the place of residence, age, social group, education level. The function of ethnic identification is associated with the Buryat language by 91.7% respondents with primary school education and by 74.7% respondents with higher university education (Istomina, 2012). The growth of education level promotes the rise of social activity, increases the functional load of the majority language and contributes to the spread of ethnic unification tendencies.

The system of language preferences among those respondents who changed their native language is focused on the use of the cross-national communication language in most spheres as an instrument of successful socialization. As a rule, the process of ethnic unification involves the communicants of the junior and middle age groups of employable population with high level of education and professional status.

As a result of urbanization, atomization in the society, the phenomenon of objective narrowing of ethnic language functions is revealed. Today, the main and sometimes the only means of communication for many ethnic groups involved in the process of intensive industry development is the Russian language. As an instrument of family communication with children, the Russian language is also used very often,

which is why many children do not perceive the language of their ethnic group as fully native; it stops being the basis for further mental and cognitive development.

The considered characteristics of language contacts from the point of view of the social system stratification, allow us to reveal the peculiarities of bilingualism in a region, which correlates to the tendencies of general ethno-linguistic development in the country. It is established that the typical features of speech behavior are in direct dependence on the peculiarities of social system structure and social characteristics of communicants. The language orientations of bilingual people express the character of transformations of individual and social settings of discourse, and also reflect the attitude of subjects to native and another language. The factors of language choice are the subjective role relations of speakers, social distance, communicative needs of the addresser and addressee, their social roles and disposition, as well as the objective peculiarities of regional language situation. The common tendency of cross-ethnic interactions for all social ethnic groups in the region is the spread of the Russian language as the means of cross-national communication and the decrease of the functional space occupied by minority ethnic languages, their shift to the family-household sphere of communication. The spread of Russian monolingualism is explained by the following socio-cultural determinants: the increase of educational and professional status, predominance of town population, social activity, affiliation with the confession of the region's ethnic majority.

**Conclusion.** In the contemporary conditions, speech behavior is regulated by the importance of the functional opportunities provided by a language, its social prospects. These properties of the regional social and linguo-cultural structure express the tendencies of development of functionally limited incomplete forms of bilingualism and the spread of unification of speech behavior in regulated official communication.

Speech behavior is the process derived from social behavior of a person. Properties and features of the social structure determine the peculiarities of functioning and development of cross-cultural contacts and language interactions in ethnically heterogeneous environment. The nature of historically developed models of contacts, the peculiarities of ethnic identification of regional groups, the psycho-cultural distance between them impact on the production of speech. The self-identification of people in a poly-cultural environment has a significant influence on the inter-ethnic balance, speech behavior of population and the whole character of cross-cultural communication.

The most effective model of communication in a poly-ethnic region should be built within a multi-lingual picture of the world (on the basis of ethnic, cross-national, international languages). Its components complement each other, deepen the understanding of native and foreign cultures, broaden the frames of language cognition, promote the development of syncretical thinking, and contribute to the formation of positive ethnic identity.

#### References

1. Bloomfield L. Language. – NY, 1933. – 564 p.
2. Goddard C. Discours and Culture/ C. Goddard & Werzbicka A. // Teun A/ van Dijk. Discours as Social interaction // Discours Sudies: A Multidisciplinary introduction. – L: Sage, 1997. – Vol. 2 – P. 231-259.
3. Habermas J. Theorie des Kommunikativen Handelns. – Frankfurt, 1991. – 385 p.
4. Haugen E.A. Study in Bilingual Behavior. – Philadelphia, 1953. – 159 p.
5. Istomina, O.B. (2009). Ethnicity as communicative resource. *Bulletin of Buryat State University. Series of Philosophy, Sociology, Political Science, Cultural Studies*, 14: 92-96 (in Russian).

6. Istomina, O.B. (2011). The criteria of defining the concept of "native language" in contemporary conditions. *Bulletin of Buryat State University. Series of Philosophy, Sociology, Political Science, Cultural Studies*, 14A: 74-80 (in Russian).
7. Istomina, O.B. (2012). *Language contacts in contemporary Russian society: Essence, forms, tendencies (regional aspect)*. Ulan-Ude: Buryat State University (in Russian).
8. Jespersen O. *The Philosophy of Grammar*. London, 1924.
9. Leopold L. *Speech development of a bilingual child*. - Chicago, 1937. - P. 251.
10. Potebnya, A.A. (1862). Thought and language. In: A.A. Potebnya (1989), *Word and myth*. Moscow: Pravda, pp. 17-200 (in Russian).
11. Ronga G. *Developpement du language observe chez un enfant bilingue*. - Paris: Champion, 1913.
12. Boronoev A. O. *Russia and Russians: the character of the nation and the fate of the country*. - St. Petersburg, 1992. - 142 p.
13. Gumilyov L. N. *Geography of an ethnos in a historical period*. - L., 1990. - 279 p.
14. Cooley C. H. *Human nature and social order*. - M., 2000.
15. Narochnitskaya N. A. *Russian and Russian in the modern world*. - M., 2011. - 416 p.
16. Pevzner M. N., Shirin A. G. *Bilingual education in the context of world experience*. - Novgorod, 1999. - 96 p.
17. Prokhorov Yu. E. *Russians: communicative behavior*. - M., 2007. - 328 p.
18. Rybakov S. E. *Anatomy of ethnic destructiveness // Herald of MSU. Sociology and Political Science*. - 2001. - No. 3. - P. 23-54.
19. Savinov L. V. *Interethnic relations in the army // Sociological studies*. - 2012. - No. 7. - P. 143-148.
20. Simonyan R. H. *Real politics or political talk show (comparative analysis of the situation in Russia and the Baltic countries // Vlast - 2005, No. 6*. - P. 30-41.
21. Toshchenko Zh. T. *Ethnocracy: history and the present times. Sociological Studies*. - M., 2003. - 432 p.
22. Fromm E. *Escape from freedom*. - M., 1995. - 256 p.
23. Hamnaeva A. Yu. *Identity as a socio-philosophical problem: diss. of cand. of philos. sciences*. - Ulan-Ude: Buryat State University, 2007.
24. Shcherba L. V. *Revisiting bilingualism / L. V. Shcherba // Language system and oral activity*. - L., 1974. - P. 313-318.
25. Schyutz A. *Favorites: World glowing sense*. - M., 2004. - 1056 p.
26. Iarskaia V. N. *My tongue is my enemy: Racist discourse in Russian society // Sociological research*. - 2012. - No. 6. - P. 46-54.

## Modern Language Policy: Specifics Of Formation And Development Of The French Vertical

Dmitry Yu. Gulinov <sup>1</sup>Marina R. Zheltukhina, Larisa A. Shestak, Gennady G. Slyshkin, Veronica V. Katermina and Ludmila D. Chervyakova

Romance Philology Department, Volgograd State Socio-Pedagogical University, Volgograd, Russia.  
Department of Theory of English, Volgograd State Socio-Pedagogical University, Volgograd, Russia.  
Department of Russian and Methods of Its Teaching, Volgograd State Socio-Pedagogical University,  
Volgograd, Russia.

Department of Social Sciences and Professional Communication, Russian University of Transport (MIIT),  
Moscow, Russia

English Philology Department, Kuban State University, Krasnodar, Russia.

Foreign Languages Department, Faculty of Philology, Peoples' Friendship University of Russia, Moscow,  
Russia

### Abstract

The relevance of the study is conditioned by the objective necessity to describe the vertical of the French language policy. The aim of the study is to identify specifics of formation and development of the modern language policy vertical in France. As material of the research, the data obtained during the analysis of legal documents concerning language policy of France, texts from modern French periodicals, fiction, media texts in the Internet, as well as the answers of the French respondents have been used. The overall corpus obtained by the continuous sampling method on the base of the French fiction comprises 3000 culturally marked names. The methods of the study include general scientific hypothetico-deductive method, introspection, contextual analysis, conceptual analysis, interpretive analysis, semantic analysis, questionnaire, elements of the quantitative analysis. In the research, general scientific methods of the analysis and synthesis, generalization and extrapolation of the findings to more wide range of phenomena were also used. The ways of analysis are useful for development of communication theory, psycho- and sociolinguistics, cultural linguistics, comparative linguistics. In the article, the concept "language policy" is defined, the main stages of language policy in France are revealed, kinds of the language policy in France are determined (retrospective, promising, constructive, destructive, centralized and non-centralized language policy). It is claimed that there are many institutions in France, whose activities are aimed at developing prescriptions on the use of the French language. In the article the main criteria of classification of prescriptions are revealed, the main prescriptions of the language policy in France are identify, and the three-level vertical of the French language policy is described and analyzed.

**Keywords:** sociolinguistics, language policy, legislative regulation of language, language policy vertical, speech portrait, norm of the French language.

### Introduction

The concept of 'language policy' is very broad and includes numerous representations. To date, definitions of this phenomenon are numerous. Let us review some of them and comment on them. In the linguistic encyclopedic dictionary (Yartseva (ed.), 1990), language policy is understood to mean the totality of ideological principles and practical measures for solving language problems in society, the state. Language policy in a multinational state is particularly difficult. In this case, it should take into account such factors as multilingualism, the uniqueness of the national composition and interethnic relations, the role of individual languages and their speakers in public life (Vakhtin & Golovko, 2004; Chervyakova, 2007; 2012; Gulinov, 2012; Shestak, 2013; 2016; Katermina, 2015; Zheltukhina et al., 2016; 2017a; 2017b; 2017c; 2017d; 2017e; Zyubina, et al., 2017, etc.). Ideological principles and practical measures



in the field of language policy are interdependent and inseparable, and since linguistic policy is an integral part of national policy, it basically depends on the general principles of the latter.

The hypothesis of the study is that the modern language policy in France represents a vertical with different levels (Gulinov, 2012). It is necessary to analyze and compare the contents and means of the French language policy. The overarching research question of this study was as follows: How can one identify specifics of formation and development of the modern language policy vertical in France?

### Methodological Framework

The aim of the research defined the choice of methods of the French language policy analysis. In the work, the following methods were applied: general scientific hypothetico-deductive method, introspection, contextual analysis, conceptual analysis, interpretive analysis, semantic analysis, questionnaire, elements of the quantitative analysis. In addition, general scientific methods of the analysis and synthesis, generalization and extrapolation of the received conclusions to more wide range of phenomena were used in the research as well. To verify the hypothesis of the French society's awareness of the issues of language policy, 100 French respondents aged 20–30 were interviewed.

As material of the research, the data obtained during the analysis of legal documents concerning language policy of France, modern texts from French periodicals, fiction, media texts in the Internet, as well as the answers of the French respondents have been used. The overall corpus obtained by the continuous sampling method on the base of the French fiction comprises 3000 culturally marked names.

Let us consider the answers to the questions of the questionnaire and comment on them.

*Question No. 1* *Connaissez-vous des mesures gouvernementales pour protéger et promouvoir la langue française? Are you aware of the measures that the state is taking to protect and promote the French language?*

When answering the first question of the questionnaire, the majority of respondents (62%) mentioned one measure taken by the state to protect the national language, namely, the creation of a new vocabulary, both highly specialized and of common meaning, which is intended to replace already existing loanwords. Thus, one of the institutions of French language policy – the General Commission of Terminology and Neology – develops and introduces original vocabulary (for example, computer-related). New lexemes are created not only based on the internal word-building resources of the French language (*ordinateur – computer, logiciel – software, courriel – e-mail*), but also by calquing a foreign language word (*toile – internet, base de données – database, cheval De Troie – Trojan horse, mise à jour – update, carte mère – motherboard, système d'exploitation – operating system, identifiant – login, lettre d'information – information letter, verrou – numlock key*, etc.).

The answers to the first question of the survey revealed a slight awareness of the French about the laws regulating the use of the French language. Only a small part of the respondents (11%) mentioned the Toubon law (*certaines lois comme celle de 1994*), which is one of the milestones of the French history of language regulation (*Lois linguistiques, s.d.*). In nearly every answer, representatives of French linguistic culture mentioned as a measure to promote the French language activities of the international organization “Francophonie”, whose main mission statements are preservation of the peoples' national heritage, development of cultural and linguistic diversity, dialogue of cultures, humane globalization (*Leclerc, s.d.*).

Let us comment briefly on the results obtained in the analysis of the first question of the questionnaire. The actual data indicate interest in preserving the purity of the French language and the increase of its prestige within the country and abroad. This is confirmed by the repeated reference to the name of the

international organization “Francophonie” standing guard over the interests of the French language speakers. One important detail should be noted: the state supports any initiative of the citizens to protect national and cultural identity. An example of this is the website of the General Delegation for the French language and the languages of France (*La délégation générale à la langue française et aux langues de France*), where the vocabulary of English origin is discussed and new terminology for potential replacement of loanwords is suggested (Politique linguistique de la France, s.d.).

*Question No. 2 A travers quels moyens de communication pensez-vous que le français est employé le plus correctement au niveau de la grammaire, de la syntaxe et de l'orthographe parmi internet, radio, télévision? In what means of mass communication, in your opinion – on the Internet, on radio, on television – the French language is used most competently from the point of view of grammar, syntax and spelling?*

Most respondents (52%) believe that the radio is the source of the ideal language, though emphasizing that the specific radio broadcast and the quality of the French language on which it is broadcast are directly related: *tout dépend des émissions car on a les deux extrêmes dans tous les médias; Dans chaque média il y a du bon et du mauvais – cela dépend de l'émission, de l'horaire de passage, du public visé, des stations particulières (it all depends on the program itself, since in any program there is both good and bad; Depends on the time of the broadcast, the target audience, etc.).*

A smaller number of respondents (38%) consider the language of television as ideal-forming. This category of respondents notes the obvious connection between the television broadcast, its genre specificity and the level of literacy provided by the authors and moderators: *ça dépend du program que l'on regarde; Pour certains programs comme le journal ou le documentaire mais pas pour les séries; Les chaînes principales – bonne réputation (it all depends on the program you are watching; this applies to news releases, documentaries, but not to serials; the main channels have a good reputation, etc.).* Finally, 10% of representatives of the French language culture believe that the exemplary French language can be found on the Internet, however, in their opinion, it all comes down to choosing a site: *tout dépend du site (it all depends on the website).*

When commenting on the answers to the second question of the survey, the respondents' preference of radio and television, where, in their opinion, the French language is exemplar, should be justified. The correct literary usage in radio and television was made possible by the law on freedom of information transfer, which obliges the members of the above-mentioned mass media to ensure the quality and diversity of programs and popularize the French language and French culture on television and on the radio.

It should be added that currently there is a quota on French radio – 40% of the songs should sound in French, and French television channels, which have chosen to show domestic-produced films as priority, enjoy substantial tax benefits from the state (Lois linguistiques, s.d.).

*Question No.3 A travers quels acteurs pensez-vous que le français est le plus correctement employé au niveau de la grammaire, de la syntaxe et de l'orthographe: professeurs, journalistes, écrivains, politiques, animateurs de télé, acteurs de cinéma? – In your opinion, representatives of which profession speak French most competently: teachers, journalists, writers, politicians, TV presenters, actors?*

The answers of the representatives of the French linguistic culture were as follows: 32% of respondents believe that the most literate in the French language are writers, 28% of the respondents prefer teachers, and 23% spoke in favor of politicians. The remaining votes were given to TV presenters (9%), journalists (5%) and actors (3%).

Let us dwell selectively on the results obtained in answering the third question of the survey and comment on them. The choice of respondents in favor of writers may be due to the existence of a special body in France that plays an important role in preserving the cultural significance of the French language and development of French literature – the French Academy. This social institution has been functioning since 1635 and its members are prominent literary figures (including writers and poets), who make a significant contribution to the modern standards of the French language (Politique linguistique de la France, s.d.).

The preference of the survey participants for politicians can be explained by the fact that many French politicians express themselves in good French, besides, the history of France abounds with examples of well-known politicians becoming initiators and developers of state orders in the field of language.

*Question No. 4 Qu'est-ce qui selon vous altère le plus la langue française? – What do you think is most harmful to the French language?*

The majority of the French who took part in the survey (43%) believe that the French language is most harmed by the language of SMS and social networks (*le langage SMS; l'absence d'efforts pour écrire correctement sur Facebook et Skype – text language; indisposition to write in Facebook and Skype competently*), 31% of representatives of the French linguistic culture believe that their native language is most threatened by loan-words from English (*l'utilisation abusive des mots d'origine anglaise dans les médias – excessive use of English words in media*), in 26% of answers, the respondents mentioned the Internet (*les nouvelles technologies en général: internet – mainly new technologies: Internet*) and reality shows (*la télé réalité*) – 17 and 9%, respectively, as the main harm to the French language.

Let us comment on some of the answers to the final question of the survey. It is no coincidence that French respondents referred to text messages as the main threat to the French language. Today, SMS-language, the emergence of which was promoted by the wide spread of high technologies, is an integral part of the French language.

The main characteristics of SMS messages – brevity, immediacy and the particular nature of content – determine their language. Simplified way of communicating via SMS leads to violations of the language rules.

The following can serve an illustration of the above said: elimination of letters (*Cfo – C'est faux*), use of one letter instead of the doubled (*Jenémar – J'en ai marre*), abbreviation using the consonant mode of writing (*bcp – beaucoup, Dsl – désolé*), use of the initial abbreviation (*M – merci, ALP – à la prochaine*), various abbreviations (*DQP – dès que possible, BAL – boîte aux lettres*), truncations (*auj – aujourd'hui, d'ac – d'accord*) and others.

Despite all the efforts made by the French language policy institutions, there is a large number of English-language loans in French. That's why the survey participants mentioned English-language vocabulary as a phenomenon that could harm the French language.

English loans in French are, first and foremost, sports vocabulary: *football, coach, handball, volleyball, beach volley, cross, goal (goalkeeper), dribble, drop, corner, rollers, footing, walk, walking, jogging, crawl, fair-play (game respecting the rules), fitness*.

The lexicon of business communication follows example of sports vocabulary: *management, business, marketing, meeting, speech, brainstorming, briefing, merchandising* (the art of selling a product or services).

In French, a lot of vocabulary related to new technologies is widely used: *mail, wi-fi, scanner, smart-phone, iphone, podcast* (digital radio or television recording that can be downloaded), *web, google* (to google), *software, chater* (to chat), *surfer, walkman*.

The list of English words, which the French use regularly in their speech practice, includes also gastronomic vocabulary: *hot dog, beefsteak, sandwich, chewing gum, fast-food, hamburger, coca cola, self-service, toast*.

The English vocabulary includes words that designate clothes: *tee-shirt, sweat, jeans, short, pull-over*.

The borrowed lexemes are also words representing various phenomena of the surrounding reality: *week-end, parking, lifting, listing, design, flyer, star, fashion, game over, shopping, challenge, baby-boom, baby-sitter, one man show, trailer, leader*, etc.

Thus, the questionnaire shows the interest of the French in preserving the purity of the French language and increasing its prestige both inside and outside the country. Most participants to the survey consider the standard language in terms of spelling, grammar and vocabulary to be the language of French radio and television. According to the respondents, writers, teachers and politicians are the most competent in French. As the phenomena that threaten the purity of the French language, the survey participants mentioned the language of SMS and social networks, as well as the excessive use of words of the English origin.

In general, despite the low awareness of representatives of the French linguistic culture of the legislative regulation of the French language (ignorance of specific laws in the field of language), the survey results make it possible to conclude that the French are involved in the implementation of state programs to preserve the purity of their native language.

## Results

In our research, we prove a hypothesis that the modern language policy in France represents a vertical with different levels (Gulinov, 2012). In what follows, specifics of formation and development of the modern French language policy vertical will be identified.

I.V. Popescu (2003) singles out several stages of language policy.

The first is the stage of the formation of goals and objectives of language policy. At the legislative level, it is expressed in the development of the state concept of ethnopolitics and language policy as its component. At this stage, a decision is made regarding the choice of the language that for some reason is considered optimal. In most cases, the language policy is perspective by nature, so its measures suggest changing the language situation and existing norms. At the first stage, the data of language forecasting are very important.

The second stage of the language policy is the preparation for the task implementation, that is, preparation for the introduction of the chosen optimal linguistic variant, its legalization. This stage is associated with so-called language planning.

Language policy can be conducted by official government agencies or independent non-governmental organizations, and therefore the "credibility" of the proposed measures will be different.

At the state level, it is the adoption of laws in the field of language functioning and accession to international treaties in this field; at the non-governmental level, it is elaboration of appeals to the government and recommendations for it, their own researches and cultural and educational activities.

This stage is closely connected with the so-called language setting, which refers to the decisions of the authorities on preserving, expanding or restricting the use of a particular language. Then comes the stage of implementation of international obligations, as well as the norms of domestic legislation in practice.

The last stage is the stage of language construction, which is characterized by the language policy resulting in efforts (including material and financial ones) aimed at forcing or persuading the speakers to accept the innovations recommended by the bodies pursuing the language policy. In this case, the speakers can accept the recommendations completely, partially or not to accept them at all. The degree of acceptance of recommendations makes it possible to evaluate the effectiveness and prospects of language policy, its results, and to forecast the linguistic development in this or that country, in this or that region (Popescu, 2003).

In the French language, in a certain period, a policy aimed at the creation of new vocabulary, both highly specialized and common, which was not reduced to the production of verbal expressions for general concepts, but also suggested the replacement of already existing lexical units of foreign origin, was proclaimed. This phenomenon is called reverse tracing, and its essence consists in replacing already borrowed and assimilated words in the language with the original words. Among such words, first of all, the technical terms *pick-up*, *tracking*, *padding* should be considered.

Once there are too many borrowings of the kind in the language, society tries to get rid of them by all available means, taking appropriate decisions at the highest level. For example, the French Committee for the Study of Technical Terminology decided to establish a national technical nomenclature and proposed options for replacing technical terms borrowed from English with the words of the French origin: *pick-up* > *capteur*, *tracking* > *cheminement*, *padding* > *tapissage*.

These are examples of a successful replacement of the borrowed English terminology. However, most English words function freely in French, and attempts to supersede them did not lead to the desired result. So, the English *businessman* and *football* are used by French speakers much more often than their French equivalents *affairiste* and *la balle au pied*. This can be explained by the fact that English borrowings took root in the minds of the French and occupied a certain niche in French public life. In addition, the meanings of words of foreign origin and their national variants often do not coincide on the connotative level (cf.: *a businessman is a businessman, an affairiste is a speculator*).

Let us turn to the characteristics and types of language policy described in the sociolinguistic literature.

Schweitzer identifies a retrospective, promising, constructive, destructive, centralized and non-centralized language policy (Schweitzer & Nikolskiy, 1978, p. 125-131).

The retrospective nature of language policy is connected with the establishment of the preservation of the existing language situation or language norms that are weakened by native speakers. As an example of this type of language policy, one can cite state measures aimed at popularizing French regional languages and cultures.

The promising nature of language policy lies in changes of the functional relationship of linguistic formations, stimulation of abolition of old norms, codification of new norms, spelling reform, and creation of terminology systems. The manifestation of a promising language policy in France is a trend towards feminization of the names of professions, positions, and titles. This linguistic fact was noted by the French General Commission of Terminology and Neology in a special report published in October 1998.

As a result of this reform, the names of professions, positions, and titles, previously used only in the masculine, acquired a feminine form: *une gouverneure* (female governor), *une professeure* (female teacher), *une ingénieure* (female engineer), *une sculpteure* (female sculptor), *une maire* (female mayor), *une chef* (female chief), etc.

A promising language policy is also the state policy aimed at the rehabilitation of regional and minority languages in France. Let us consider the case of the Breton language. At present, teaching in Breton is allowed officially in Brittany, television and radio broadcast in this language, books, newspapers and magazines are published. In addition, Brittany use a bilingual signal system on the roads and a number of public services. A special role is played every year by the grandiose holidays of Breton culture, which gather hundreds of thousands of people. All this speaks for a certain perspective of the development of the language, in other words, about the promising language policy in relation to the Breton language.

Language policy aimed at changing the language can be constructive and destructive. Constructive policy is the policy aimed at expanding the communicative functions of languages, scope of their application, social and communicative role, and creation and development of literary languages.

In recent years, France has implemented a number of programs to rehabilitate the languages of the French regions. Such a policy with respect to regional languages, the preservation of their status, and expansion of their communicative potential can be called constructive. Despite the categorical nature of Article 2 of the Constitution of the French Republic, which says that *the language of the Republic is French*, *La langue de la République est le français* (Full text of the Constitution of 1958 as amended on July 23, 2008), today the prospects of the development and strengthening of the positions of regional languages are evident. This is a constructive policy for the revival of the Breton, Basque, Catalan, Alsatian, Occitan (Provençal) and other regional languages.

An example of destructive language policy is the rigid policy of eradicating regional variants of the French language, which was proclaimed in France in the 16th century. The history of French language policy knows a decree of 1539, which prescribed the use of French in governmental and judicial acts and the establishment of the French Academy in 1635. The revolution promoted the process of linguistic unification so that citizens express their thoughts in the same language, guaranteeing the unity and indivisibility of the Republic. Hence the decisive intention to eradicate the languages of the regions (Ponto, 2007, p. 91). The active process of ousting regional languages was observed at that time in schools. Thus, primary school teachers imposed various punishments, including bodily punishment, for using the words of the local language.

A centralized and non-centralized language policy should also be distinguished. Centralized language policy is pursued by the state and provides for a system of compulsory measures.

For example, in 2009 the Ministry of Culture and Public Affairs of France prepared a report on the measures taken by various organizations and institutions undertaken in defense of the French language. This centralized language policy was aimed at establishing control over the use of the French language in such spheres of public life as food, industrial production, leisure and sports. In the reporting year, special attention was paid to food products of foreign origin (fish, canned goods, cheeses). Some food products that arrived on store shelves from abroad were not accompanied by the necessary information in French. In a number of cases, instructions and operating instructions for industrial goods of foreign origin were not translated into French. Finally, in the sphere of leisure and sports, the facts of improper registration in the French language of guidelines on the use of personal protective equipment during active recreation and sports activities were revealed.

Non-centralized is the policy of local authorities that doesn't have statutory force outside the region, as well as the language policy pursued by public organizations and scientific societies. Today there are many public organizations competent in the implementation of language policy in France, among which the following should be noted: *Association francophone d'amitié et de liaison* (Francophone Friendship and Cooperation Association), *Avenir de la langue française* (Future of the French language), *Défense de la Langue française* (Protection of the French language), etc. The main purpose of these organizations is to preserve and develop the French language, which is common to fifty French-speaking countries, no matter in what relations these countries are with France.

The above-mentioned organizations defend the right to work in French, consume goods and services in French, choose foreign languages for study at school, communicate in French with institutions and organizations of the European Union (in compliance with the 1958 decree guaranteeing the equality of all the official languages of the countries, Members of the European Union).

Questions of language policy, an obligatory part of the overall policy of the state, are quite acute and topical at the present stage, which determines the relevance of their linguistic analysis (Schweitzer, Nikolskiy, 1978; Grishaeva, 2007; Klovov, 2009; Marusenko, 2011, etc.).

The importance of accounting for language policy is an indicator of the viability and effectiveness of the state, while non-observance of linguistic policy can lead to a violation of the integrity of the state and ethnic tragedies. The dynamics of modern society, new trends in politics, economics, cultural life of the country, peoples are reflected in the language and, of course, require their own linguistic interpretation.

A careful examination of the history of French language policy shows the constant interest of the French in preserving and developing the language and resisting the influence from the outside (Kuralesina, 2011; Gulinov, 2015). In this regard, it should be noted that the language policy in France, focused on the preservation of national identity, is consistent and systematic.

One of the priorities of the French language policy is the enrichment and renewal of the national language, which manifests, in particular, in replacing borrowed words of English origin with the original words. Attention is drawn to the fact that a set of measures to deliberately influence the language that forms the basis of linguistic policy is not only a consequence of the state relation to the functioning and development of the language, but also the reaction of the society that requires the state to be correct in this or that matter (Minyar-Beloruhev & Pokrovskaya, 2007). In other words, the state becomes an object of influence, and is forced to obey the public moods.

To implement the language policy in France, a number of institutions have been set up, whose activities are aimed at developing prescriptions on the use of the French language.

The main prescriptions of the language policy are laws and regulations on language, language reforms, as well as any decisions taken by the state or any other social body that has the right to do so, aimed at regulating the use of language units or the use of the language as a whole.

The prescriptions can be classified based on the following criteria: the nature of the impact, scope of distribution, intended addressee.

Depending on the nature of the effect, prescriptions can be divided into obligatory and optional. In the first case, these are the prescriptions that are followed strictly; in the second case, they are recommendatory in nature.

An example of obligatory prescriptions is the Bas-Lauriol law (loi Bas-Lauriol), which prohibits the use of foreign terms if there are equivalent original words. The illustration of prescriptive prescriptions is the replacement of the English borrowing *e-mail* (e-mail) by the French word *mel*, obtained by combining the first letters of the phrase *messagerie électronique*. Another lexeme designating e-mail (*courriel* – from *courrier électronique*), appeared in the French-speaking province of Canada Quebec. In French, this term began to be introduced actively only in 2003 after its publication in the Official Gazette of the Republic. The use of the words *mel* and *courriel* is advisory in nature, it is for this reason that in everyday communication in France any words referring to e-mail can be found: *e-mail*, *mel*, *courriel*.

Depending on the scope of distribution, centralized and local prescriptions are distinguished. The centralized character is seen in the prescriptions that provide for a system of compulsory measures. For example, in 2009, the Ministry of Culture and Public Affairs of France prepared a report containing the measures taken by various organizations and institutions to protect the French language. Such prescriptions were necessary to control the use of the language in such spheres of public life as food, industrial production, leisure and sports.

As for local prescriptions, they include, first, any initiatives of local authorities (in the form of laws, decrees, and other documents) that do not have statutory force outside the region. An example of this type of prescriptions is the activity of local authorities in preserving the identity of the languages of the French regions. This not only speaks in favor of preserving regional languages, but also witnesses the prospects for their development, the transfer of their original character from generation to generation by introducing them as a subject into primary schools. This is largely due to prescriptions of a local character in the revival of regional languages.

Depending on the intended recipient, there are prescriptions targeting an institutionally prepared audience, and prescriptions addressed to the public. The users of language policy that receive instructions on the use of the language within ministries and departments can be referred to as institutionally prepared audience.

The algorithm for developing this type of prescriptions is as follows: terminological neoplasms are born in the inmost recesses of the specialized commissions on terminology and neology under ministries and departments, and then the General Commission of Terminology and Neology discusses them. Finally, neologisms are transferred to the approval of the French Academy, after which new units of the language are published in the Official Gazette of the French Republic and become mandatory for use by public services.

Here is an example of prescriptions addressed to a given type of addressee. The General Commission of Terminology and Neology posted on one of its websites about 6,000 new lexicon units, which still have to undergo the approval procedure of the French Academy. Neologisms are classified according to the thematic principle and correspond with the following fields of science and technology: *Arts* (the Arts), *Astronomie* (Astronomy), *Automobile* (Automobiles), *Biologie* (Biology), *Défense* (Defense), *Environnement* (Environment), *Santé et médecine* (Health and medicine), *Transports* (Transport), etc.

For example, the thematic area *Santé et médecine* contains 74 lexical units, among which the following new ones appear: *absorbeur*, *aidant*, *axénique*, *bacterial bandage*, *bandage de contention*, *biothèque* (Biobank), *claquade* (slapping as a kind of massage), *éveinage* (removal of varicose veins), *lissage* (flattening), *plateau technique* (technical platform), *urgentiste* (ambulance doctor), etc.

The above inventory of lexemes is intended for use by medical workers, and, therefore, is addressed to institutionally employed persons.



The opposite type of prescriptions is aimed at the public. Thus, the main administration of the French language through the website [wikilf.culture.fr](http://wikilf.culture.fr) appeals to the citizens of France to take part in activities aimed at protecting the French language from foreign influence. For example, the above website offers for discussion the following terms of English origin: *edit* (editorial), *blogueur* (blogger), *wiki* (technology of user interaction with the website, designed for collective development, structuring and storage of information), *photowalk* (photowalk), *freak* (freak), *dress code* (recommended clothing style), *flirt* (flirt), *Living lab* ("live" laboratory), *facebook* (facebook), etc.

The discussion of words is held in the section *de quoi s'agit-il* (what is it about?), in which the etymological meaning of the word is revealed. It is followed by the section *des pistes pour se renseigner* (for reference), containing links to texts in which the word occurs. Finally, in the key rubric *proposition* (suggestion) the term considered as a potential substitute for a borrowing is given. So, as a replacement for the English borrowing *self-discount*, the word of the French origin *libre-*vrac** appears, which fully reflects the principle of the functioning of special self-service departments in hypermarkets (*libre* = self-service + *vrac* = goods without packaging, per weight).

Thus, having analyzed the activity of the institutions of language policy aimed at developing prescriptions on the proper use of language, the existence of a vertical of the French language policy should be recognized.

## DISCUSSIONS

Some scholars identify the language policy with "practical measures of the state relating to the status of the state language, its functions, protection of the monopoly use of the state language in the most important social spheres, regulation of the use of local languages" (Belikov, Krysin, 2001, p. 263). In this case, "the main tool of language policy should be laws on the language that can be created only on the basis of comprehensive knowledge of its functional properties, the degree of development of certain systems in it, a more or less detailed idea of the possibilities of language in the various social and situational conditions of its application" (Ibid., p. 264).

The above definition of language policy refers to any form of decision taken by the state for orientation and regulation in the field of the use of one or several languages. The dominant position here is given to the state language and its status.

However, another point of view exists. French linguist L.-J. Rousseau considers language policy as "any decisions taken by the state or any other social body entitled to this, aimed at using one or more languages in a given territory, real or virtual, and regulating its use or their use" (Rousseau, 2007, p. 97).

In this definition, language policy is considered from two positions - general and private. From the position of the general understanding, it correlates with any decisions of the state (social institution, organization) on the use of a language in a given territory. From the position of the private understanding, language policy is related to the competence of the state or other social body to make any decisions on the regulation of the language use in a given territory.

In the definition by the well-known linguist A.D. Schweitzer language policy appears as "a set of measures taken by the state, party, class, social grouping to change or preserve the existing functional distribution of languages or linguistic subsystems, introduce new or maintain existing linguistic norms" (Schweitzer, Nikolskiy, 1978, p. 117).

The key words in this definition of language policy are "change" and "preservation". In the opinion of A.D. Schweitzer, language policy is aimed not only at preserving the existing state of a particular

language, but also at changing it, in demand by time and society: the revival of national traits, creation of new vocabulary. This definition of language policy is on tune with the terms “language construction” and “language planning” widely used in sociolinguistic literature.

S.N. Kuznetsov defines language policy as a system of measures implemented by the state, the union of states, influential social institutions and cultural figures for preserving or changing the language, language group, linguistic or communicative situation (Kuznetsov, 2001, p. 40).

According to N.B. Vakhtin and E.V. Golovko, the language policy of the state is part of the overall policy of the state. The state adopts basic principles of the policy regarding the languages that are circulated on its territory and implements this policy in the form of language planning (Vakhtin, Golovko, 2004, p. 163).

Let us consider a point of view on the content of the concept of language policy that belongs to V.A. Aurorin. In his opinion, “the language policy of a certain social class, party, state is a system of measures of deliberate regulatory influence on the functional side of language, and through its medium, to a certain extent, also on its structure” (Aurorin, 1975, p. 10). V.A. Aurorin emphasizes the organized and focused nature of language policy, the object of which is not the language and its structure, but the functional side of the language.

The opinion of A.D. Schweitzer is in tune with the above view: “in most cases the language system or the language subsystem is undergoing changes not under the direct influence of the society, but indirectly, due to the expansion or narrowing of private communicative functions” (Schweitzer, Nikolskiy, 1978, p. 117).

The definition of the “language policy” concept, proposed by V.T. Klovov, can be summarized in the the following statement: “Language policy is a deliberate and purposeful influence on the functional and structural fields of the language by official and unofficial persons, public organizations, parties, governments, classes, etc.” (Klovov, 1992, p. 9). In the definition, V.T. Klovov draws attention to the fact that the language can be influenced by both people in an appropriate position, and ordinary citizens participating in the processes of language regulation.

Another understanding of language policy is found in (Mechkovskaya, 1996): “Language policy is all kinds of deliberate activity of the society aimed at regulating the use of the language” (Mechkovskaya, 1996, p. 199).

Summarizing the various interpretations of one of the key concepts of sociolinguistics, we will show the basic coordinates by which the multifaceted phenomenon is specified:

1. Language policy is a set of measures taken by the state, any other body in an appropriate position, public and private figures to influence the language deliberately.
2. Language policy is a deliberate and purposeful influence with the aim of preserving or changing the existing state of the language.
3. Measures developed in the framework of language policy are aimed at the functional side of the language, but through its medium and its own structure.

It can be claimed that the vertical of the French language policy has several levels. The first level is represented by the first persons of the state (the president, ministers), public figures, and officials capable of influencing the current language situation in the country, initiating language laws and regulations that determine the state policy in the field of language as a whole. At the second level, there are institutions of

language policy – state and public structures, whose activities are aimed at preserving the identity of the language, as well as regulating the processes of language development. At the third level, there are consumers of language reforms developed by state institutions.

Let us consider each of the levels separately.

The history of France contains numerous evidences of well known politicians becoming initiators and developers of state orders in the field of language. To this day, famous politicians take a direct part in the implementation of the policy in the field of language, it is for this reason that the language issue often becomes part of the electoral program of presidential candidates. As an example, pre-election programs of French presidential candidates in 2012 and 2017 (Francois Hollande, Marin Le Pen, Nicolas Sarkozy, Emmanuel Macron, etc.) can be mentioned, which referred to the issues of the language life of the French society.

As noted above, at the second level of the vertical of language policy in France are the institutions of language policy. State bodies whose activities are aimed at preserving and developing the language are referred to the institutions of language policy. It is due to the activities of the above commission in the French language that a lot of neologisms of aboriginal origin appeared. For example, the computer sphere has been updated with such original terms as *administrateur système* (system administrator), *adresse électronique* (e-mail address), *aide* (aid), *bande passante* (passing band), *carte mère* (motherboard), *corbeille* (basket), *courriel* (E-mail), *espioniciel* (spyware), *gratuiticiel* (free program), *fichier* (file), *logiciel* (software), *mémoire vive* (RAM), *mise à jour* (update), *ordinateur* (computer), *pare-feu* (Fire partition), etc.

Finally, the third level of the vertical of the French language policy is represented by ordinary people. At the same time, they act not only as passive consumers of language reforms, but also as active participants in solving the problems of the language life of the society.

## Conclusions

Therefore, as a result of the conducted research it has been established that language policy is a set of measures taken by the state, any other body in an appropriate position, public and private people to deliberately influence the language. The language policy supposes deliberate and purposeful influence with the aim of preserving or changing the existing linguistic situation. It has been proved that measures developed in the framework of language policy are aimed at the functional side of the language, but through its medium and the structure of the language itself.

The main stages of language policy in France have been revealed: 1) setting of goals and objectives of language policy; 2) preparation for the implementation of the task, that is, preparation for the introduction of the chosen optimal linguistic variant, its legalization; 3) language planning at the state and non-governmental levels; 4) language setting, which refers to the decisions of the authorities on preserving, expanding or restricting the use of a particular language; 5) implementation of international obligations, as well as the norms of domestic legislation in practice; 6) language construction as adoption of the innovations recommended by the bodies pursuing the language policy.

Kinds of the language policy in France have been defined: retrospective, promising, constructive, destructive, centralized and non-centralized language policies.

It has been established that to implement the language policy in France, a number of institutions had been set up, whose activities are aimed at developing prescriptions on the use of the French language. The main criteria of classification of prescriptions have been revealed: depending on the nature of the impact, scope of distribution, intended addressee. It has been proved that the main prescriptions of the

language policy in France are laws and regulations on language, language reforms, as well as any decisions taken by the state or any other social body that has the right to do so, aimed at regulating the use of language units or the use of the language as a whole.

Thus, having analyzed the activity of the institutions of language policy aimed at developing prescriptions on the proper use of language, the existence of a three-level vertical of the French language policy should be posited: 1) the first persons of the state (the president, ministers), public figures, officials capable of influencing the current language situation in the country, initiating language laws and regulations that determine the state policy in the field of language as a whole; 2) the institutions of language policy – state and public structures, whose activities are aimed at preserving the identity of the language, as well as regulating the processes of the language development; 3) consumers of language reforms developed by state institutions.

Implications and recommendations for future studies are as follows. For achievement of efficiency of the language policy in France, it is necessary to investigate methods and means of forcing or persuading the speakers to accept all language innovations.

Based on the findings of this study, it is possible to analyze and compare the contents and means of language policy in different linguocultures. It should be noted that the future study could form integrated communicative algorithm for realizing language policy of the state. It is recommended that linguistic and cultural development of the research should include complex methods, which would be integrated into research process and should be discussed by experts in the fields of linguistics, sociology, psychology, politics, business, etc. The next step in the development of this research will be development of an algorithm of implementation of a linguoculturally specific language policy of the state.

### References

- Avrorin, V.A. (1975). Problemy izucheniya funktsionalnoy storony yazyka: K voprosu o predmete sotsiolingvistiki [Problems of Studying the Functional Aspect of the Language: Revisiting the Subject of Sociolinguistics]. Leningrad: Nauka. (In Russian).
- Belikov, V.I., & Krysin, L.P. (2001). *Sotsiolingvistika* [Sociolinguistics]. Moscow: Russian State Humanitarian University. (In Russian).
- Chervyakova, L.D. (2007). 'Sootnoshenie printsipov regulirovaniya rechevogo obshcheniya i reche vogo etiketa v delovoy kommunikatsii' [Correlation of the Principles of Regulation of Speech Communication and Speech Etiquette in Business Communication]. *Vestnik RUDN. Questions of Education Series: Languages and Profession*, 3: 11–18. (In Russian).
- Chervyakova, L.D. (2012). 'Vliyanie dostizheniy etnopsikologii na etnokulturnuyu spetsifiku formirovaniya mezhkulturnogo delovogo obshcheniya' [Influence of Achievements of Ethnopsychology on Ethnocultural Specifics of Cross-Cultural Business Communication Formation]. S.I. Kudinov, Ye.N. Reznikov, Z.V. Boyko, I.A. Novikova, Yu.A. Chudina (eds.), *Aktualnye problemy etnicheskoy, sotsialnoy i differentsialnoy psikhologii: Materialy Mezhdunarodnoy nauchnoy konferentsii molodykh uchenykh, studentov i aspirantov. Moskva, RUDN, 6–7 dekabrya 2012 g.* [Current Issues in Ethnic, Social and Differential Psychology: Proceedings of the International Scientific Conference of Young Scientists, Students and PhD Students. Moscow, Peoples' Friendship University of Russia, 6–7 December 2012]. Moscow: Peoples' Friendship University of Russia, 209–216. (In Russian).
- Grishaeva, E.B. (2007). Tipologiya yazykovykh politik i yazykovogo planirovaniya v polietnicheskom i multikulturnom prostranstve: funktsionalnyy aspekt [Typology of Language Policies and Language Planning in a Multi-Ethnic and Multicultural Space (Functional Aspect)]. Author's Abstract of a PhD Thesis. Krasnoyarsk: Krasnoyarsk State University. (In Russian).

- Gulinov, D.Yu. (2012). 'Vertikal yazykovoy politiki Frantsii' [Vertical of Language Policy of France]. *Vestnik Kostromskogo gosudarstvennogo universiteta*, 18(3): 53–56. (In Russian).
- Gulinov, D.Yu. (2015). Diskursivnye kharakteristiki yazykovoy politiki sovremennoy Frantsii [Discursive characteristics of the language policy of modern France]. PhD Thesis. Volgograd: Volgograd State Socio-Pedagogical University. (In Russian).
- Katermina, V.V. (2015). 'Emotsii v khudozhestvennom tekste' [Emotions in the Art Text]. *Inostrannye yazyki: ligvisticheskie i metodicheskie aspekty*, 32, 134–139. (In Russian).
- Klokov, V.T. (2009). 'Sovremennyy vzglyad na razvitie frantsuzskoy yazykovoy politiki' [Modern View on the Development of French Language Policy]. *Izvestiya Saratovskogo universiteta. New Series. Series: Philology. Journalism*, 9(3): 3–10. (In Russian).
- Kuralesina, E.N. (2011). *Evolutsiya yazykovykh politik Frantsii i Kanady v sravnitelno-istoricheskom aspekte* [Evolution of the Language Policies of France and Canada Viewed in Comparative and Historical Perspective]. PhD Thesis. St Petersburg: St Petersburg State University. (In Russian).
- Kuznetsov, S.N. (2001). 'Modeli yazykovoy politiki v russkoyazychnom obshchestve' [Models of Language Policy in the Russian-Speaking Society]. In: M.L. Remneva, A.A. Polikarpov (eds.), *Russkiy yazyk: istoricheskie sudby i sovremennost. Mezhdunar. kongress: Trudy i materialy* [Russian Language: Historical Destinies and the Present: Intern. Congress: Proceedings and Materials]. Moscow: Moscow State University Press, 308–309. (In Russian).
- Leclerc, J. *L'aménagement linguistique dans le monde* (Electronic resource). URL: <http://www.tlfq.ulaval.ca/AXL>
- Lois linguistiques.* (Electronic resource). URL: <http://www.axl.cefan.ulaval.ca/Langues/LOIS-LINGUISTIQUES-index.htm>
- Marusenko, M.A. (2011). *Yazykovaya politika Frantsii* [Language Policy of France]. St Petersburg: St Petersburg State University Press. (In Russian).
- Mechkovskaya, N.B. (1996). *Sotsialnaya lingvistika* [Social Linguistics]. 2nd ed. Moscow: Aspekt-Press. (In Russian).
- Minyar-Beloruchev, A.P., & Pokrovskaya, M.E. (2007). 'Politicheskaya korrektnost i yazykovaya norma' [Political Correctness and Language Norm]. *Vestnik Yuzhno-Uralskogo gosudarstvennogo universiteta, Series: Linguistics*, 1(73): 27–31. (In Russian).
- Politique linguistique de la France.* (Electronic resource). URL: [https://fr.wikipedia.org/wiki/Politique\\_linguistique\\_de\\_la\\_France](https://fr.wikipedia.org/wiki/Politique_linguistique_de_la_France)
- Ponto, M. (2007). 'Yazykovye politiki v multikulturnom prostranstve. Yazykovaya adaptatsiya immigrantov. Sluchay Kanady' [Language Policies in Multicultural Space. Language Adaptation of Immigrants. The Case of Canada]. In: *Yazykovaya politika v sovremennom mire: po materialam Tretego i Chetvertogo mezhdunar. seminarov po gos. yazykovoy politike i aktual. problemam dvuyazychiya (Parizh, 2005; SPb., 2005–2006)* [Language Policy in the Modern World: Proceedings of the 3rd and 4th International Sessions on the State Language Policy and Current Issues of Bilingualism (Paris, 2005; St Petersburg, 2005–2006)]. St Petersburg: Zlatoust, 143–145. (In Russian).
- Popescu, I.V. (2003). *Teoreticheskie osnovy yazykovoy politiki* [Theoretical Foundations of Language Policy]. (Electronic resource). URL: <http://www.russian.kiev.ua/archives/2003/0310/031029ep01.shtml> (In Russian).
- Rousseau, L.-J. (2007). 'Razrabotka i provedenie v zhizn yazykovoy politiki' [Development and Implementation of Language Policy]. In: *Yazykovaya politika v sovremennom mire: po materialam Tretego i Chetvertogo mezhdunar. seminarov po gos. yazykovoy politike i aktual. problemam dvuyazychiya (Parizh, 2005; SPb., 2005–2006)* [Language Policy in the Modern World: Proceedings of the 3rd and 4th International Sessions on the State Language Policy and Current Issues of Bilingualism (Paris, 2005; St Petersburg, 2005–2006)]. St Petersburg: Zlatoust, 97–121. (In Russian).
- Schweitzer, A.D., & Nikolskiy, L.B. (1978). *Vvedenie v sotsiolingvistiku* [Introduction to Sociolinguistics]. Moscow: Vysshaya shkola. (In Russian).

- Shestak, L.A. (2013). 'Prikladnye modeli yazyka: kognitivnaya i didakticheskaya modeli' [Applied Models of Language: Cognitive and Didactic Models]. In: S. Masalova V. Solovyev (eds.), *Kognitivnoe modelirovanie : Trudy Pervogo Mezhdunarodnogo foruma po kognitivnomu modelirovaniyu (14–21 sentyabrya 2013 g., Italiya, Milano Marittima)* [Cognitive Modeling: Collection of Papers of the First International Forum on Cognitive Modeling (14–21 September, 2013, Italy, Milano-Marittima)]. In 2 parts.. Part 2. Rostov-on-Don: Southern Federal University Press, 374–377. (In Russian).
- Shestak, L.A. (2016). 'Kartina mira v narodnom slove' [Worldview in a People's Word]. *Izvestiya Volgogradskogo gosudarstvennogo pedagogicheskogo universiteta*, 9–10(113): 143–146. (In Russian).
- Vakhtin, N.B., & Golovko, E.V. (2004). *Sotsiolingvistika i sotsiologiya yazyka* [Sociolinguistics and Sociology of Language]. St Petersburg: Gumanitnaya Akademiya. (In Russian).
- Yartseva, V.N. (ed.). (1990). *Lingvisticheskiy entsiklopedicheskiy slovar* [Linguistic Encyclopedic Dictionary]. Moscow: Sovetskaya entsiklopediya. (In Russian).
- Zheltukhina, M.R., Biryukova, E.V., Gerasimova, S.A., Repina, E.A., Klyoster, A.M., & Komleva, L.A. (2017a). 'Modern Media Advertising: Effective Directions of Influence in Business and Political Communication'. *Man in India*, 97(14): 207–215.
- Zheltukhina, M.R., Mouzykant, V.L., Barabash, V.V., Ponomarenko, E.B., Morozova, E.V., & Mori, S. (2017b). 'Russian and Japanese Younger Generations in Search for a New Media Product'. *Man In India*, 97(3): 223–236.
- Zheltukhina, M.R., Slyshkin, G.G., Muzykant, V.L., Ponomarenko, E.B., & Masalimova, A.R. (2017c). 'Functional Characteristics of the English and Russian Media Texts about the Sochi 2014 Winter Olympic Games: Political and Linguistic Aspects'. *XLinguae Journal*, 10(3): 83–100.
- Zheltukhina, M.R., Vikulova, L.G., Kovaleva, N.A., Ryanskaya, E.M., & Fomina, Zh.V. (2017d). 'Symbolic Nature of Culture: Features of the English Floristic Symbolics in Modern Economic and Political Media Texts'. *Man in India*, 97(14): 61–71.
- Zheltukhina, M.R., Vikulova, L.G., Mikhaylova, S.V., Borbotko, L.A. & Masalimova, A.R. (2017e). 'Communicative Theatre Space in the Linguistic and Pragmatic Paradigm'. *XLinguae Journal*, 10(2): 85–100.
- Zheltukhina, M.R., Zinkovskaya, A.V., Katermina, V.V., & Shershneva, N.B. (2016). 'Dialogue as a Constituent Resource for Dramatic Discourse: Language, Person and Culture'. *International Journal of Environmental and Science Education*, 11(15): 7408–7420.
- Zyubina, I.A., Matveeva, G.G., Zheltukhina, M.R., Slyshkin, G.G., & Shevchenko, A.V. (2017). 'Forensic Prosecutor's Speech as a Speech Genre'. *XLinguae Journal*, 10(3): 312–323.

## Linguacultural Specificity Of Transferring The Category Of Comic By The Language Means

Aida G. Sadykova<sup>1</sup>, Diana F. Kajumova<sup>2</sup>, Diana N. Davletbaeva<sup>3</sup>, Gulnara H. Aleeva<sup>4</sup>, Elena L. Iakovleva<sup>5</sup>, Marina A. Zaichenko<sup>6</sup>, Galina V. Matveeva<sup>7</sup>

<sup>1</sup>Department of Germanic Philology, Kazan (Volga region) Federal University, Kazan, Russia.

<sup>2</sup>Department of Germanic Philology, Kazan (Volga region) Federal University, Kazan, Russia.

<sup>3</sup>Department of Germanic Philology, Kazan (Volga region) Federal University, Kazan, Russia.

Department of Germanic philology, Kazan (Volga region) Federal University, Kazan, Russia<sup>4</sup>

<sup>5</sup>Department of Philosophy and Socio - Political Disciplines, Kazan Innovative University named after V.G. Timiryasov, Kazan, Russia

<sup>6</sup>Department of Philosophy and Socio - Political Disciplines, Kazan Innovative University named after V.G. Timiryasov, Kazan, Russia

<sup>7</sup>Department of Library Science, Bibliography and Documentation, Kazan State Institute of Culture, Kazan, Russia.

### Abstract

The urgency of the problem stated in the article is due to the fact that the issues of adequate reflection in the translation of linguistic stylistic means have always been the most difficult and controversial. The purpose of the article is to describe the system of communicative and pragmatic means of creating a comic effect in the original and non-original artistic texts. The leading approach to the study of this problem is a communicative and pragmatic approach, based on semantic-stylistic, comparative methods, the method of linguistic description of the artistic text with the involvement of linguocultural analysis. The main results of the article are an analysis of the creation of the comic effect, which are subdivided into lexico - stylistic and lexico - semantic techniques, such as slang used by the author, vernaculars, blasphemy in the speech of their heroes; at the heart of the lexico - semantic technique is associative - figurative rethinking: comparison, metaphor, metonymy, epithet.

**Keywords:** Pragmatic equivalence complete, types of equivalence, syntactic, levels of equivalence, adequate communicative effect, partial, zero equivalence, semantic.

### Introduction

The study of the linguistic means of comic texts and their translations was carried out on the material of the stories of M. Twain and S. Likok. The category of comic (comoedia), originating from antiquity, is introduced into aesthetics as a necessary logical correlator of the tragic category. L. Mukarzhovskiy, one of the founders of structuralism, points to certain properties common to the whole comic sphere, which consists in the fact that the two semantic links are opposed, in the light of which this reality is considered (Mukarzhovskiy, 1994). A certain stage in the comprehension of the comic and its types of connections with the concrete historical approach to laughter phenomena is realized in the works of M.M. Bakhtina, L.E. Pinsky, D.Ya. Cropp and others.

The background of it is briefly formulated by V.Ya. Cropp: "We do not laugh the way we laughed at one time" (Cropp, 1976). Comic is such an incriminating spiritual defect creature that physically expose itself with laughter. D. Ya. Cropp derives the general theory of the comic, which consists in the fact that we laugh when in our awareness the positive beginnings of a person are overshadowed by the sudden discovery of hidden flaws suddenly opening through the cover of external data (Cropp, 1999).

The category of comic, dating back to antiquity, includes categories of comic, laughter and humor, necessitating the definition of the relationship between them. In the modern interpretation, the comic and the comical are presented as two almost combined concepts, but the comic is culturally designed and meaningfully important.

Humor in its narrow sense is a kind of comic, and in a broad sense, humor is the ability of a person or a social group to perceive the comic in all its diversity.

Comic is an integral part of any culture, so this phenomenon is currently very relevant from the point of view of its representation at the verbal level.

### Methodological Framework

The methodological basis of this research is the system - communicative approach, which includes pragmatic and linguocultural approaches. In the study of the comic category, we proceeded from methodological thoughts about the spread of language and speech. Cultural - historical environment and an instrument of cognition of dialectical interaction, rational and emotional thinking.

The empirical way was to solve the problem of considering the linguistic and pragmatic nature, the methods of realizing the comic short story in the genre. This was achieved with the help of sophization analysis, elements of cognitive interpretation, descriptively - comparative method, discourse - analysis, and systematic analysis.

A review and analysis of theoretical material has shown that the comic appears as a triune linguistic culture in language and communication. This category includes philosophical and aesthetic, sociocultural, biopsychological and linguistic aspects, a substantive plan and a system of means of expression. In terms of volume, the comic unit can range from word and phraseology to the superphrasal unity of the whole text. In discourse, the comic unit is a comic speech act.

### Materials

The theory of comic has now been called the geological theory (Panina, 1996). And represents the logical completion of the cyclical development of the knowledge of the comic within the framework of different paradigms.

This theory is of a synanetic nature and includes the study of the category of comic on different levels: Emotive, mental and actually linguistic (Panina, 1996).

Of particular importance is the interaction of different linguistic cultures within the framework of intercultural communication, that is, "The area of potential conflict interaction between the social-determined cognitive discursive models (Tsurikova, 2006), intercultural interaction from the standpoint of the cognitive discursive approach to the question of cognitive linguistics.

### Results

Speaking about the role of the word as a comic means, we have in view of the disinational-stylistic role of commonly used words, archaisms, dialectisms, neologisms, professions, mutations and vulgarisms, organic words and expressions of proper names of nicknames and titles. In comic art, polysigmatism of words, homonymy and synonymy, antonymy and comic play of words are widely used.

The basic receptions in creation of comic are considered in the article, they are subdivided into:

1. Lexico-stylistic (lexicon of the lower style: vernacular, slang, blasphemy)
2. Lexico-semantic (metaphor, pun, wordplay, hyperbole)



Lexical-stylistic techniques are lexical units, contrasted in neutral according to different stylistic parameters:

1. By fixation for certain spheres of speech, genre, combined representations of functional styles, vernaculars, slangisms, and vulgarisms are distinguished.
2. On the historical parameters of speech: Historisms, archaisms.
3. On the basis of "His own": exemptions, barbarisms.
4. On social parameters: Jargonisms Argotisms (Zoller, 1996).

These parameters correspond with the stylistic marking, which exist objectively in the language and the relationship from which is perceived by participants in the communicative act, as a signal called to produce a defined impression, the effect of the impact. Most often, such as lexical units have an orally emotional-estimated color. For example, «Hello, Billy», - says Silver; «I'm glad to see you. Yes, it seems to me that the West was accumulating a little too much wiseness. I've been saving New York for dessert. I know it's a low-down trick to take things from these people. They only know this and that and pass to and forth and think ever and anon. I hate her my mother to know I was skinning these weak-minded ones. She raised me better» (O. Henry «Babes in the jungle»)

Before us is the speech characteristic of the New Yorkers, an expressive element is formed, forming a stylistic layer and creating a comic effect.

Quite successfully this layer was transferred in translation: "Ah, Billy! -Novil Silver. -I am glad to see you. Yes, in the West, you know, all that is very clever. I've already saved myself a New York for sweet. Of course, it's not very nice to rob people like New Yorkers. They can count up to three, dance only to the stove, and think once a year for a promise. I would not want my mother to know that I am cleaning up such stupid people . She did not educate me for that." «Translation of E.Kalashnikov».

The eloquence of expressive vernacular is widely used in the dialogical speech of characters with an official and usually familiar style.

Slang is practically an open subsystem, not a normative lexico-phraseological unit. Speaking of the common language, its stylistic variety (Chemist, 2000).

Slang expressions differ from the neutral vocabulary of the literary standard, ethical-stylistic lowering of different qualities: from jokingly ironic to destructive expression and sharply negative emotional evaluation with strictly familiar communication. For example, in O. Henry's story: "Christmas my injunction" And we had in the way of their blume with that Lizzy wine I speak of, so I never eat on ("Christmas injunction" O. Henry.) And we had time order to be loaded with this very pop. No, I did not say anything to him (translation by T. Ozerskaya).

In this example, the translator uses vernaculars to adequately translate the slang expression and retain some expressiveness; when translating fizzy wine (sparkling wine), the interpreter successfully used the colloquial word "pop"; that will impart expressiveness and negative appraisal to words.

With the usage of vulgarisms in an artistic text, an important point is an analysis of the changes in the socially expressive coloration of the words of the examined common rock. "Blasphemy", as a kind of vulgarism, is widely used in artistic prose to create a comic.

"Good lord! it's one trouble after another, Lordy! How I've Upset. "(Proof of the Pudding by O. Henry). My God, what a misfortune! One by one ... Oh, my God, I'm not myself! (translation by M. Bogoslovsky).

Such a speech in the story is used as a parody of sublime speech, abundant use of blasphemous interjections in the literary text warns them of "blotting out", they lose unpredictability and are semantically devastated, turning into empty forms.

Thus, among the lexico-semantic examples, we have studied slang, vernacular and blasphemy in the speech of their heroes and their translations into Russian. The impact of non-standard vocabulary is almost always accompanied by forcing the speaker's emotions, changes in expressive coloring

The analysis of the linguistic material made it possible to reveal that the reduced vocabulary, namely vernacular, slang, vulgarism and blasphemy are more often used in the stories of O. Henry and M. Twain than in S. Likok, and in the stories of M. Twain we can meet words that are labeled in the dictionary as vulgarisms and refer to the most reduced layer of vocabulary. In the stories of S. Likok, as a rule, more neutral vocabulary is used, as a result of which they are less expressive and emotionally colored.

The next group that has been researched is a lexico-semantic means of expressing the comic, at the heart of this method is an associative imaginative rethinking, namely the tropes. In the formation of paths, associative thinking plays an active role. Trails reorganize the semantic space of the language, removing in it the boundaries between the real and possible. Such methods as comparison, metaphor, metonymy and epithet are considered. A comparison is a figurative verbal expression in which the phenomenon depicted is explicitly likened to another in some common characteristic for them, and at the same time new non-ordinary properties are singled out in the comparison object, for example: "Will: you are wasting your time, because he is deaf and dumb, and as blind as a badge. Then you wasted your time: he is deaf, dumb and blind as a bat! (translated by N. Daruzes).

The most common trail is a metaphor. With its implementation in the text, the metaphor can also update the characteristics of a literal meaning, creating a single metaphorical context. Expressive metaphor acts as a means of expressing emotional evaluation. For example: "Oh, and the curt two hours tripped by on rose wings" ( O.Henry) . The next two hours flew on pink wings (translation by E. Kalashnikov).

The difference between metaphor and metonymy is that the metaphor creates a verbal image by projecting two different denotative spaces on each other, as metonymy converts into the basic apposition of two verbal rituals within the same denotative space, for example: "It Its 9:45 o'clock and not just a single picture of a pineapple, chewing gum has been shown up yet ("The business of a busy Brober", O. Henry "). Now, 9:45, but still no fashionable hat and no stick of chewing gum appeared (translated by M. Laurier).

Our research and analysis of the material made it possible to reveal that in the stories of O. Henry, M. Twain, S. Likok, comparisons, epithets are used most frequently and are translated into Russian using, as a rule, the same linguistic means. metaphor and metonymy are found in the stories of the same authors much less often.

In such means of creating a comic, as pun and play of words, with all the strength are all the national peculiarities of humor through its national language form.

Satyrical - humorous effect in the language of stories is achieved by mixing various lexical, grammatical and phonetic discrepancies, which are very characteristic of the authors of some stories.

O. Henry and M. Twain are typical images of the usual for the southern areas of common speech - grammatical and phonetic deviations from the norm. In Russian, the data of deviations are transmitted, as a rule, by the means reception of communication, that is, the speech is incorrectly transmitted by the common vocabulary, or by imitation of the accent and dialect.

### Discussions

The theoretical basis for this study was the work of foreign and domestic researchers: I.S. Bazhenova (2003), M.M. Bakhtin (1997), V.Ya. Cropp (1997), Yu.N.Karaulov (2003), B (2002), I.S.Babenko (2000), V.S. Elistratov (1995), K.F. Sedov (2005), E.Bern (1988), A.P. Moskovsky (2005) , M.O. Mendelson (2005), V.V. Khimik (2000), V. Frank (1990), and Z. Freud (1991).

However, the analysis of scientific works devoted to the problem of reflection of the comic category does not fully reflect the study of the linguistic nature of the comic effect, the disclosure of the mechanism of the consistent and systematic embodiment of the author's design in the text space.

The study of the comic in lingvopragmatics is connected with the well-known principle of GI Gris's cooperation, which derived the postulates of quantity, quality, relevance and clarity and showed that their observance leads to a comic effect (1) Searle derived the concept of a humorous speech act. He treats it as an individual manifestation of the stimulus to something funny.

Comic reflects objects and phenomena of reality and are characterized by internal contradictions, that is, a discrepancy between what they are and what they say they are, and the contradiction between the imperfection of mankind and its positive experience, its aesthetic ideals.

### Conclusion

It is established that the comic is characterized by verbal signs:

- 1) philosophical and aesthetic: the opposition of the derided phenomenon to aesthetic ideals; ambiguity, paradox, contrast, opposition, inconsistency;
- 2) sociocultural: social orientation, international and national - subjective;
- 3) linguistic: lingvopragmatic and linguistic proper: language game, violation of compatibility at all levels of language, reliance on analogy.

Lexical - stylistic and lexico - semantic means of categorization of the comic are revealed. The main processes of creating comic in the everyday consciousness of English speakers. in the study is a language game: slang, vulgarisms, comparisons, metaphors, metonymy and epithets. Comic is created at all levels of the language (phonology, morphology, vocabulary, syntax). through the word - and phrase-forming processes as through semantic derivation and a combination of these processes.

It is reflected that the means of creating the comic largely depend on the author's language locality, the way of expressing the worldview, which grows out of the perception of life as a mixture of lyrical and comic.

It is proved that the speech behavior of a person is different from the cultural traditions of society; each social role corresponds to a certain type of speech behavior, its own set of language tools. In the stories of M. Twain, O. Henry and S. Likok, the sociocultural components of idiostyle are manifested in the comic situation created by the author. Comedy perception is identified by the national psychic character, national cultural traditions, the aesthetic ideal of comic comprehension. In the works of O. Henry in the

speech of the heroes, the background values and vocabulary of the "business" person are fancifully combined. In M. Twain's works originality was manifested in the use of jargon, sharp words, and using scientific (pseudoscientific) vocabulary in S. Likok's works a subtle irony framed with bookish (high) vocabulary is realized. It is determined that the analyzed short stories reflect various contradictions of reality.

It is established that vernacular is an integral part of the national language and is widely spoken in oral speech if in English linguistics vernacular always is outside the boundaries of the literary language, then in the Russian tradition it is formed as a phenomenon located on the periphery.

### Acknowledgments

- 1) The work is performed according to the Russian Government Program of Competitive Growth of Kazan Federal University.
- 2) Taking into account the results of this research, we can single out its further prospects: the study of the full range of tools that make up the idiostyle of M. Twain, O. Henry, S. Likok, and the reproduction of their individual "picture of the world."

### References:

- Babenco, N.S. (2000). *Language: theory, history, typology*, Moscow: Art, 512.
- Bakhtin, M.M. (2000). *The author and hero of aesthetic activity*. Saint Petersburg: Credo, 336.
- Bazhenova, I.S. (2003). *Emotions, pragmatics, text, monograph text*. Moscow: Publishing house "Manager", 386.
- Bell, R. (1991). *Translation and Translating: Theory and Practice*. London and New York: Longman, 84.
- Blokh, M.Ya. (1983). *Theoretical grammar of the English language*. Moscow: Higher education school, 147 - 191.
- Chemist, N. (2000). *Poetics of low or vernacular as a cultural phenomenon*, Moscow: Progress, 13.
- Cropp, V.Ya. (1976). *Folklore and reality. Selected articles*. Moscow: Pedagogical education and science, 83-115.
- Cropp, V.Ya. (1999). *The problems of comic and laughter*, Moscow: Labyrinth, 288.
- Fillmore, C h. (1968). *The case for case. Universals in Linguistic*. New York, 1-88.
- Grice, T.V. (1978). *Logic and speech communication. New in foreign linguistics*. Moscow: Progress, 16, 217-237.
- Ilyish, B. (1992). *The Structure of Modern English*. Moscow: Higher education school, 22.
- Karaulov, Yu.N. (2003). *Linguodidactic representation of the language personality and its structure*, Moscow: Publishing House of the Russian State University for the Humanities, 38.
- Kazak, M. Yu. (2010). *Intertextual models of media texts*. Belgorod: Science, 347-354.
- Krasnykh, V.V. (2002). *National Discourse and Communication. Ethnopsycholinguistics and linguoculturology. Lecture course*. Moscow: ITDGK "Gnosis", 5.
- Morokhovskaya, E. (1978). *Fundamentals of Theoretical Grammar*. Moscow: Progress, 217-237.
- Mukharzhovskiy, I. (1994). *Research on aesthetics and theory of art*. Moscow: Art, 606.
- Panina, M.A. (1996). *Comic linguistic means of its expression: the dissertation of a Cand. Phil.s*. Moscow: Moscow University Publishing house, 145.
- Pinskiy, L.E. (1989). *The main plot*. Moscow: Contemporary writer, 412.
- Quirk, R., Greenbaum S., Leech G., Svartvik J. (1982). *A University Grammar of English*. Moscow: Vysšaja škola, 102-103.
- Revskeya, N.N. (1976). *Modern English Grammar*. Publishing House of the Russian State University for the Humanities, 228.
- Serge, J. (1986). *What is a speech act. New in foreign linguistics*. Moscow: Progress, 151-169.

Skrebnev, T. (1994). Y.M. Fundamentals of English stylistics. Moscow, 158.

Solopov, A.I. & Antonets, A.V. (2016). Textbook and practical exercises. Moscow: Publishing house of Moscow University, 272.

Tsurikova, L.V. (2006). Discursive strategies as an object of cognitive - pragmatic analysis of communicative activity, 122.

Zimmerman, J. E. (1980). Dictionary of Classical Mythology. Moscow: Bantam Books, 10.

ALLEN

## The Adequacy Of The Reflection Of The Comic By Means Of Another Language: Translation Equivalence And Adequacy.

Diana F. Kajumova<sup>1</sup>, Aida G. Sadykova<sup>2</sup>, Gulnara H. Aleeva<sup>3</sup>, Luiza R. Zakirova<sup>4</sup>,  
Galina V. Kolpakova<sup>5</sup>, Liliya I. Galeeva<sup>6</sup>, Gulnara A. Arslanova<sup>7</sup>

<sup>1</sup>Department of Germanic Philology, Kazan (Volga region) Federal University, Kazan, Russia.

<sup>2</sup>Department of Germanic Philology, Kazan (Volga region) Federal University, Kazan, Russia.

<sup>3</sup>Department of Germanic Philology, Kazan (Volga region) Federal University, Kazan, Russia.

<sup>4</sup>Department Germanic Philology, Kazan (Volga region) Federal University, Kazan, Russia.

<sup>5</sup>Department of Germanic Philology, Kazan (Volga region) Federal University, Kazan, Russia.

<sup>6</sup>Department of Management, Institute of Social and Humanitarian Knowledge, Kazan, Russia.

<sup>7</sup>Department of International Relations, Kazan (Volga region) Federal University, Kazan, Russia.

### Abstract

The urgency of the problem is caused by the fact that the issues of adequate reflection in the translation of linguistic means, preservation of the style in translation have always been the most difficult and controversial. It is obvious there is the need to understand as deeply and fully as possible what is common to different people, that is universal human cultural values, to preserve carefully and correctly transmit them while translating from one language to another. The purpose of the article is to compare the translation of the linguistic means of expressing the comic into Russian in short stories (based on the stories of M. Twain, O. Henry, S. Likok). The leading approach to the study of this problem is communicative and practical on the provisions of the theory of translation, which makes it possible to reveal that translation is not a simple modification of some linguistic structures into others, but an important mean of intercultural communication. The main results of the article are that, when considering equivalence, translators often resort to translation at the component and reference levels. The equivalence and adequacy relation is reflected in the paper, five types of equivalence proposed by V.V. Komissarov are examined. Equivalence levels are considered. and three levels of equivalence proposed by Breus E.V. Regularities in language systems that dictate the only contextual possibility of adequate transmission of the content of the text are considered. Materials can be useful in the training of professional specialists in theory and practice of translation, they also consider the problems of translation theory in terms of a comparative analysis of the communicative and pragmatic potential of various languages.

**Keywords:** Adequate communicative effect, types of equivalence, levels of equivalence, syntactic, semantic, pragmatic equivalence complete, partial, zero equivalence.

### Introduction

In the artistic translation, the main task of an interpreter is to convey the artistic and aesthetic merits of the original, creating a full-fledged artistic text in the language of translation. In modern translation studies, the opinion has been established that the translation of the type of interlingual and intercultural communication is based on the production of a text that adequately replaces the original text in another culture, in another language and in another communicative situation (Schweizer, 1988).

It is on this path that there is a way to achieve equivalence, which implies the incomplete identity of the two texts, and "sufficient commonness of their content for the purposes of communication in specific conditions" (Komissarov, 1990: 7). In the science of translation, "sufficient generality of content" is given the status of a multifaceted statistical concept - an equivalence complex ("equivalence global") that presupposes the existence of all its main components: denotative, connotative, genre, pragmatic, formal - aesthetic.

The communicative equating of multilingual texts in the translation process is accompanied by more or less significant changes. In this regard, one of the central concepts of translation theory is the "equivalence" of translation, which denotes the relative generality of translation and the original in the absence of their identity and is considered as the main sign "the condition for the existence of translation. American researcher J. Naida argues that the translation consists in creating in the translation language "the nearest natural equivalent to the original (Naida, 1978). An adequate translation can only be that translation, which accurately conveys not only the meaning, but also the expressive - stylistic features of the primal. Translation must perform certain functions: informative, informative, aesthetic, etc. (Toper, 2000). The ratio of equivalence and adequacy in each act of translation is determined by the choice of strategy that the translator makes based on a number of factors that make up the translation situation. The most important is the purpose of translation, the type of translation text and the nature of the intended receptor for translation.

The terms adequacy and equivalence have long been used in translation studies. V.N. Komissarov considers "equivalent translation" and "adequate translation" as concepts that are not identical, although they are closely related to each other. The term "adequate translation", in his opinion, has a broader meaning. The term "equivalence - as a semantic community of equals to one another language and speech units" (V.N. Komissarov, 1990).

V.S. Vinogradov understands by equivalence in the theory of translation: "the preservation of the relative equality of meaningful semantic, stylistic and functional-communicative information, contained in the original and in translation (Vinogradov, 2001). The main task of comparatively equivalent research is the establishment and analysis of equivalence relations between the two languages. The most acceptable interpretation of the adequacy of translation in relation to the artistic text is the idea of the effect put forward by J. Naida.

The relevance of the topic is due to the need to develop effective translation techniques that provide deep penetration into the nationally determined meanings of original literary works and thus contribute to the comprehension of the axiological priorities of the people through the prism of its artistic culture. The text spaces of short stories by M. Twain, O. Henry and S. Lykok are considered in the article, united by a common pragmatic attitude towards creating a comic effect, and their translation into Russian.

### **Methodological Framework**

The translation task of adequate semantic reproduction presupposes a careful analysis of the communicative and pragmatic organization of the original text in the subsequent formation of a system of examples and means of creation, the need for a pragmatic effect in the text of translation that is provided by a functional adequate original of the organized complex of native language means. An important ability of an interpreter to find interlanguage linguopragmatic correspondences in native language systems.

In the process of research the communicative - pragmatic approach and the method of lexico - grammatical transformations were used. A comparatively-equivalent approach presupposes the concept of "dynamic equivalence" put forward by Yu. Naida. It draws attention to the cultural aspects of translation. The problem of translational equivalence is not exhausted by its description at the grammatical and semantic levels, it is required to identify the patterns of the use of linguistic means in specific situations, that is, it is necessary to taken into account the pragmatic aspect of language communication. At this level, the most complex transformations are encountered, such methods as adding and feeling, full paraphrased or compensated.

Translation as one of the most important types of communicative activity is guided, first of all, by a complete and adequate transfer of the language of the original containing the entirety of the implications of the linguistic, social and cultural plans. The difficulties of translation are connected not with the

knowledge of the language, but with the ability of an interpreter to find lingual-geological regularities in linguistic systems. Translation is carried out by the universal principle of the unified organization of all specific languages, based on the essence of language as a form of representation of real activity (Zhuk, 2002). Some features of the translation of stylistically marked vocabulary: (based on the work of O. Henry). In this paper, translation is seen as a channel for interaction and mutual understanding of cultures and languages.

A communicative, pragmatic approach to translating literary texts is faced with the problem of translational equivalence. One approach to solving the problem of translational equivalence is to try to find in the content of the original some invariant part, the preservation of which is necessary and sufficient to achieve the equivalence of the translation. Another approach to the definition of translational equivalence is empirical. Its essence lies in the fact that it is not a priori to decide what the commonality of the translation and the original was, but to compare a large number of completed translations with their originals and see what their equivalence is based on.

### Results

The most developed method of studying the translation process is the creation of theoretical models of translation. The translation model is a conditional picture of the procedure for the implementation of the translation process, based on an attempt to extend some general postulates of linguistics and psychology to translation. (Komissarov, 2002). The most important task of translation theory is to identify linguistic and extra linguistic factors. Translational equivalence is the real semantic closeness of the texts of the original and translation, reached by the translator in the translation process. There were considered 5 types of equivalence proposed by V.N. Komissarov.

The equivalence of the first type of translation consists in preserving only that part of the content of the original that constitutes the communication goal: "I do not ever eat" em. (The Pimienta Pancakes by O. Henry) - I do not take them into my mouth (translation by M.Urasov).

In this case, the meaning of the statement remains, but the logical content is completely lost.

For relations between originals and translations of this type are stored:

1. The incompatibility of the lexical composition and syntactic organization;
2. Impossibility to connect the vocabulary and the structure of the original and the translation by the relations of semantic rephrasing or syntactic transformation;
3. Absence of real or direct logical connections between the messages in the original and the translation, which would make it possible to assert that in both cases the same thing;
4. The smallest commonality of the contents of the original and the translation as compared with all other translations are deemed equivalent.

In the second type of equivalence, the general part of the content of the original and the translation not only conveys the same purpose of communication, but also reflects the same extralinguistic situation.

The second type of equivalence is represented by translations, the semantic closeness of which to the original is also not based on the generality of the meanings of the used linguistic means.

"Jeed was a monopolist by nature ..." Jed was born for monologues ("The Pimiera Pancakes" by O. Henry) (translated by M. Urasov).

In this example, the translator successfully uses other lexical means, which gives more expressiveness and evaluation.



For relations between originals and translations of this type there is the characteristic:

- 1) incompatibility of lexical composition and syntactic organization;
- 2) the inability to relate the vocabulary and the structure of the original and the translation by the relations of semantic rephrasing or syntactic transformation;
- 3) Preservation of the communication goal in translation, since preserving the dominant function of the utterance is an obligatory condition for equivalence;
- 4) Preservation in the translation of an indication to the same situation.

The third type of equivalence is characterized by the possibility of paraphrasing the original message in a translation message that reveals the common seminal community. Here, a communicative goal is achieved and a way of describing the situation is preserved. "I do not know why I said" alone "" - Why I said "face to face", I do not recognize this myself. ("My Financial Career", S. Lykok) (Translated by D. Livshes).

In this example, the semantic load is successfully preserved, phraseology "face to face" better conveys the emotional state of the hero.

Comparison of originality and translations of this type reveals verbal features:

- 1) the absence of parallelism in lexical composition and syntactic structure;
- 2) the inability to relate the structure of the original and the translation by the relations of syntactic transformation;
- 3) the preservation in the translation of communication goals and identification of the same situation as in the original;

4) preservation of common concepts in translation, with the help of which the situation in the original is described, that is, the preservation of that part of the content of the source text, which we called "a way of describing the situation" (Komissarov, 2002). Thus, in these three types of equivalence, it was a question of conveying the elements of meaning whose preservation is possible with a significant discrepancy of linguistic means, through which this meaning is expressed both in the original and in translation. Now it is required to find an equivalent correspondence to the values of linguistic units of a foreign language. In the following two types of equivalence, the semantic community of the original and the translation includes not only the preservation of the communication goals, an indication of the situation and the way it is described, but also the closest possible proximity of the values of the correlated syntactic and lexical units. Here, the information is saved not only "for what", "what", "what" is said in the text of the original, but also partly "as it is said". «I haven't anything against you, but I can't let my daughter marry of love, art, and starvation». In the fourth type of equivalence, a significant part of the syntactic structure of the original is reproduced in the translation. The structural organization of the original represents certain information that is included in the general content of the translated text (Komissarov, 2002). The maximum possible preservation of the syntactic organization of the original in the translation facilitates of a more complete reproduction of the contents of the original. In addition, the syntactic parallelism of the original and the translation provides the basis for correlating the individual elements of these texts, refuting their structural identification by communicants.

"I have nothing against you, but I can not allow my daughter to marry a combination of love, property and hunger." ("The Capitoline Venus", M. Twain) (translated by N. Daruzes).

The relationship between the original and the translation of the fourth type of equivalence is characterized by verbal features:

1) A significant, though incomplete, parallelism of the lexical composition - for most of the original words one can find the corresponding words in a translation with a close content;

2) Use in translation of syntactic structures analogous to the structures of the original or related syntactical variation relations, which ensures the most harmonious transfer of the meaning of the syntactic structures of the original;

3) the preservation in the translation of all three parts of the content of the original: the communication objectives indicated on the situation and the ways of its description.

In the last, fifth type of equivalence, the maximum degree of proximity of the content of the original and the translation that can exist between texts in different languages is achieved.

"Before him lay a pile of blue papers with printed headings." "Before him lay a pile of blue sheets with printed headlines." ("Romanse in one chapter", S. Likok) (Translated by D.Livins).

Here we see an almost complete translation, where the translator used all the necessary means to achieve the greatest adequacy and equivalence of the translation.

«He would not play hockey, even taken his sober judgment told him it was the most profitable thing he could do». («The story of a good little boy», M.Twain).

For the relationship between originals and translations of this type is characteristic:

- 1) High degree of analysis of the structural organization of the text;
- 2) Maximum correlation of lexical composition: in translation it is possible to indicate compliance with all significant words of the original;
- 3) preservation in translation of all the main parts of the contents of the original.

The levels of equivalence that are distinguished by Breus E.M.

Has a hierarchical principle, from the lowest to the highest. Each level has its own translational transformations (Breus, 2001).

The lowest level of equivalence is called syntactic. Translation on it is reduced to the replacement of some lexical signs by others while preserving the syntactic structure of the utterance.

"He would not play hockey, he was even the most profitable thing." "He did not miss the lessons and did not beat the buckets, even when the sober voice of reason prompted him that this would be the most useful time for him to pass." ("The story of a good little boy", Mark Twain) (translated by M. Apkok). «The manager looked relieved but still serious» («My Financial Career»)

At the reference level, the character of the translation changes also, if at the sublevel of component equivalence the translation is carried out mainly through grammatical transformations, then on the referential sublevel it is a question of more complex lexico-grammatical transformations affecting not only to the grammatical structure of the utterance, but also its lexical content.

"The manager looked relieved but still serious" ("My Financial Career", S. Likok) - "The manager, apparently, relaxed from the heart, but he was still on his guard" (Translation by D. Livshits).

The highest place in the hierarchy of equivalence levels is pragmatic. At the two previous levels of compliance established within the same function - denotative. Now the basis for comparison in translation is the two main links of the communicative process - communicative setting and communicative effect, and the relation to the text from the sender and receiver. The relationship between the sign and the user is called pragmatics. Hence the name of this level is pragmatic equivalence. At a pragmatic level, the transformations of a different kind of sensations, additions, and full paraphrases are

conjugated. "Willie," says "," Chizhik, "I say." (The Pimienta Pancakes by O. Henry) (translated by M.Urnov).

At the pragmatic level - depending on the recipient's background knowledge the new information is added, or, conversely, some of the data in the original is omitted. In other words, at the semantic and pragmatic levels it is a matter of partial equivalence. To express the differences in the degree of equivalence of the translation, both categories are of an evaluation nature. But if equivalence is oriented towards the purpose of translation and in this sense is an ideal constructor, then adequacy is associated with specific conditions of the translation process and reflects its optimal result.

### Discussions

The study of comic theories offers various interpretations and terminology regarding concepts related to the comic sphere. This indicates the continuing relevance of the object of research, located in the intersection of various sciences, capable of offering new approaches and important adjustments to the traditional understanding of the comic.

Translation is a complex and multifaceted activity. It is no longer a simple modification of some linguistic structures into others, but a complex process of conveying the meaning of an utterance, defined as the result of the interaction of linguistic meanings and cognitive fillings corresponding to this utterance. A study of the translation of the comic texts of the authors M.Twain, O. Henry, S.Lekok in Russian from the position of a communicative and pragmatic translation is carried out for the first time.

The multi-faceted research interest in the format of modern translation research, the "dialogue of cultures", has become more productive and significant than ever in recent years, and is the subject of attention and study of a number of sciences: Philosophy (Osadgiy), Cultural Studies (Bakhtin, Bibler), cultural theory of translation (Galeeva, Donskov, Timko, Trukhtanova, Phogel), semiotics (Lotman).

There are many theories of translation reflecting certain of its features as acts of interlingual communication. Among them is one of the most developed it is offered in the works of German scientists O. Kade and A. Niebert. By its development in domestic linguistics, communicative theory is largely due to the research of scientists V.N. Komissarova and A.D. Schweitzer.

### Conclusion

Thus, we considered the equivalence relation and the adequacy of the translation of a foreign text into the native language. Translation, as one of the most important types of communicative activity, focuses primarily on the full and adequate transfer of the original language. We investigated 5 types of equivalence. As the study showed, most often translators resorted to the use of the second and third types of equivalence in translating the stories of O. Henry, M. Twain, S. Likok into Russian.

In our work equivalence levels were considered: equivalence at the lowest level, at the communicative level, at the reference level and at the highest level - pragmatic. Most often translators resort to translation at the component and reference levels.

The main pragmatic task of translation is to create a text in the target language that has the ability to have a similar artistic and aesthetic impact on the receptors of translation. If the translator managed to achieve this, we can talk about an adequate reproduction of the communicative effect of the original.

Research materials can be useful in practical terms for translation activities, in the development of effective translation techniques.

### Acknowledgments

- 1) The work is performed according to the Russian Government Program of Competitive Growth of Kazan Federal University.

2) Taking into account the obtained results of this research, it is possible to single out a number of scientific problems and promising directions that require further consideration; translation of bi-equivalent vocabulary, literal and free translation, study of the full range of means reflecting the ideology of M. Twain, O. Henry, S. Likok with the purpose of reproducing their individual picture of the world.

### References

- Bell, R. (1991). *Translation and Translating: Theory and Practice*. London and New York: Longman, 84.
- Bakhtin, M.M. (2000). *The author and hero of aesthetic activity* Saint Petersburg: Azbuka, 336.
- Bibler, V.S. (1991). *Mikhail Mikhailovich Bakhtin. Or poetics of culture*. Moscow: Progress, 176.
- Blokh, M.Ya. (1983). *Theoretical grammar of the English language / Theoretical grammar of the English language*. Moscow: Higher education. school, 147 - 191.
- Breus, E.V. (2001). *The Theory and Practice of Translation from English into Russian: Tutorials*-Moscow: URAO, 1-104.
- Cropp, V.Ya. (1976). *Folklore and reality. Selected articles*. Moscow: Pedagogical education and science, 83-115.
- Cropp, V.Ya. (1999). *The problems of comic and laughter*, Moscow: Labyrinth, 288.
- Efremova, N.E., E.I. Bolshakova, A.A. Noskov, V.Yu. Antonov (2010). *Terminological analysis of the text on the basis of lexico-syntactic patterns - Computer linguistics and intellectual technologies: based on materials annually. Intern. Conf. Dialog' 2010, 9 (16)*. Moscow: Publishing House of the Russian State University for the Humanities, 124-129.
- Kade, O. (1978). *Translation Problems in the Light of Communication Theory*, in: *Problems of Translation Theory in Foreign Linguistics.-International Relations*, Moscow: Publishing house of Moscow University, 232 .
- Khayrullin, V.I. (2005). *Lingvocultural and cognitive aspects of translation*. - Saint Petersburg: Azbuka, 355.
- Komissarov V.V. (1990). *Translation theory*. Moscow: High School, 1990 - 252 p.
- Mukharzhovsky, I. (1994). *Research on aesthetics and theory of art*. Moscow: Art, 606.
- Naida, Yu. (1978). *To the science of translation. Questions of the theory of translation in foreign linguistics*. Moscow: 114-135.
- Pinskiy, L.E. (1989). *The main plot*. Moscow: Contemporary writer, 412.
- Revskaia, N.N. (1976). *Modern English Grammar*. Moscow: Publishing House of the Russian State University for the Humanities, 47.
- Schaffner, C. (2007). *Politics and Translation. Companion to Translation Studies*. Cleve don: Buffalo, 57.
- Schweizer, R. (1988). *Translation theory: the status of the aspect problem*. Moscow: Science, 215.
- Scott, S. (2006). "Art and the Archaeologist". *World Archaeology*, 38, 628-643.
- Serge, J. (1986). *What is a speech act. New in foreign linguistics*. Moscow: Progress, 17, 151-169.
- Shakirova, G.R., Kharisova, Ch.M. & Kharisov, F.F. (2016). 'The development of language competence of students in the study of the native language morphology'. *Journal of Language and Literature*, 7: 227-230.
- Solopov, A.I. & Antonets, A.V. (2016). *Textbook and practical exercises*. Moscow: Progress, 28.

- Teliya, V.N. (1996). Role of figurative means of language in the cultural and national color outlook. Moscow: Ais-Press, 12-132.
- Tooper, P.M. (2000). Translation in the system of comparative literature. Moscow: Heritage, 253.
- Trukhtanova, E.V. (2001). The use of cognitive frame theory in a comparative translation of an artistic text. II Language, culture and intercultural communication. Moscow: Publishing house of Moscow University, 125-132.
- Tsurikova, L.V. (2006). Discursive strategies as an object of cognitive - pragmatic analysis of communicative activity. Moscow: Progress, 467.
- Vinogradov, V.S. (2001). Introduction to translation studies. General and lexical questions. Moscow: IOSO RAO, 224.
- Zhuk, L.M. (2002). Modern linguistics: theory and practice. Krasnodar: Credo, 51-57.

## Public Trust Of The Population In Economic Reforms: A Theoretical And Practical Aspect

Elena V. Kamneva <sup>1</sup>, Marina V. Polevaya <sup>2</sup>, Sergey A. Polevoy <sup>3</sup>, Nikolay S. Prjazhnikov <sup>4</sup>,  
Tatiana V. Folomeeva <sup>5</sup> & <sup>6</sup> Eleonora V. Egorova

<sup>1</sup> Department of Personnel Management and Psychology, Finance University under the Government of the Russian Federation, Moscow, Russia.

<sup>2</sup> Department of Personnel Management and Psychology, Finance University under the Government of the Russian Federation, Moscow, Russia.

<sup>3</sup> Department of Management, Finance University under the Government of the Russian Federation, Moscow, Russia.

<sup>4</sup> Department of Personnel Management and Psychology, Finance University under the Government of the Russian Federation, Moscow, Russia.

<sup>5</sup> Faculty of psychology of the Moscow State University named after M.V. Lomonosov, Moscow, Russia.

<sup>6</sup> Institute of International Relations, Ulyanovsk State University, Ulyanovsk, Russia.

### Abstract

The importance of the study is determined by an insufficient level of trust of the population in the economic reforms conducted in the country. Unfortunately, a considerable part of Russians experience, a strong disappointment in the reforms of the 90-s as well as a protracted «period of transition» to a more developed economy and social sphere. The successes of some countries (like China, India, Vietnam...), that have smaller resources but were able to mobilize their intellectual and managerial potential for more stable social and economic development, aggravate such mistrust. In this connection, this article is directed to identifying or revealing the major causes of such mistrust and the search for the ways of increasing trust. At the theoretical level external and internal variants of approval/disapproval of the authorities' reforms and various types of trust in the authorities and reforms are also analyzed. The specific features of trust in reforms in various age and social groups of the population have been identified in empirical research (in students and specialists who are working currently and connected with the economy, business and management). The article contains the results of the theoretical analysis of the problem of trust by the population to the reforms of the authorities. The types of trust and the causes of insufficient approval of reforms have been revealed, one of them is the insufficient assessment of a moral component of the transformations conducted and insufficient personal involvement of the population in the process of reforms itself. In empirical research the differences in attitude to reforms were found out in students and working specialists. There is an interesting fact among them that students are bolder in their assessments and their position is mainly based on their understanding the essence of reforms rather than in specialists who work. The necessity of special studies is substantiated not only in relation to the presence of attitude to reforms but the dynamics itself of such an attitude as well as the search for managing these processes for the purpose of a greater involvement of various groups of the population in the conducted reforms.

**Keywords:** public trust, social and economic reforms, external and internal opposition of the population, counteraction to reforms.

### Introduction

The essential feature of the reforms conducted in the last decade in contemporary Russia can be reduced to the provision of the RF citizens' well-being growth, the creation of a developed economic model of the state, integration of the Russian economy in the world market. The greatest efforts of the government were concentrated on the reforms in the spheres of macroeconomic regulation-restructuring of the economy, the creation of the innovative economy; the labor market – the creation of innovative vacancies,

the pension reform, professional standards, employment of the population, introduction of the efficiency contract; housing and communal services; the general and tariff reform of natural monopolies; the tax sphere, the transport branch of industry.

The most important condition of economic reforms' efficiency is psychological and even personal «acceptance» of these reforms by the majority of the country's population. The reforms stipulate the change not only the character itself of economic activity (introduction of new technologies, the shift of focus from some spheres of activity to another, the development of the labor market and so on.), but also the change of self-consciousness both in the population and in executives themselves.

The problems arise at that moment when «public trust» itself (and close to it «loyalty» and «adherence») are understood in a simplistic way which leads to both the self-deception of the trustful population and the self-deception of the authorities. Unfortunately, in management, not infrequently innovations are conducted under conditions of «pseudo-loyalty» (sham, externally demonstrable «loyalty» with internal misunderstanding or even contempt to innovations) and «pseudo-adherence» (when this «adherence» is not even related to clear goals and values or when the strong discord is observed between the declared and real goals (Riseberg, 2012). Consequently, the concept «public trust» itself should be specified, its specific character, with regard to various groups of the population and on this basis to identify the types of «public trust» and its levels. This, in its turn, would allow one to develop more efficient ways of controlling public trust, bringing it in an ideal form to the level of high consciousness and confidence of the majority of the population in the right choice of the economic course that would lead to an active and conscious participation of the population in the reforms conducted by the authorities.

Reforming assumes the change not only the character itself of economic activity (introduction of new technologies, the shift of focus from some spheres of activity to another ones, the development of the labor market and so on.), but necessarily the change of self-consciousness of the population. Not without reason people think that «any reform, apart from the moral one, does not have any sense» (Borokhov, 1998).

Reforms themselves can bare the character of essential changes when the main emphasis is placed on the change of the attitude to labor, to colleagues and consumers, but can imitate essential changes, not infrequently limiting itself to a change of signboards and replacement of some top officials. Besides, reforms can be caused by objective reality which is impossible to ignore, but can also be caused by subjective factors, for example, by the country's leadership understanding the necessity of changes in the economy (the top-down initiative), or by comprehending the necessity of essential transformations from the populace and its representatives among the progressive intellectual class, scientists, teachers... (the down-top initiative).

It is understandable that favorable conditions for reforms are those when the «top» and «down initiatives» coincide. But this presupposes the organization of special managerial efforts from the authorities that require the explanation to the people the essence of reforms, support for all «adherents» of changes and also – to provide counteraction measures against resistance to reforms.

Mass consciousness has already become a subject of a special study as early as the time of publishing G. Lebon's well-known work «Psychology of the masses» (Lebon, 1995). A well-known point which was used by Marxists at certain stages of history – «the masses are the creators of history» – in contemporary approaches it is frequently cast doubts on (Ortega y Gasset, 1998; Pryazhnikov, 2011). More often the masses are considered as «incompetent», «susceptible to manipulations» (Reich, 2004).

But the masses can be constructive if to raise their education level, if to provide special informative work on the propaganda of reformative ideas. Real reforms of the global systems must be not purely economic ones but be oriented to raising the quality of life of the population. It is then they will find understanding and response among the majority of citizens i.e. all serious reforms must be social and economic ones.

The same picture in reforming organizations: innovative ideas are firstly established in the consciousness of top officials, then in the consciousness of mid and low level executives, then in the consciousness ordinary staff members of the organization. Attention is paid here not only to technologies but also to new organizational values.

Trust in the authorities undertaking reforms can be formed and manifested in different ways. Formative models of the population's trustful attitude to social and economic reforms of the authorities is determined mainly by the following factors: 1) readiness and persistence of the authorities to conduct intended reforms; 2) a skilful propaganda of main reformative ideas; 3) by authority of executives-reformers themselves (their readiness to change their economic behavior and way of life, for example, to give up excessive luxury); 4) the level of general culture and self-respect of the main part of citizens in the country; 5) examples of similar reforms in other countries (Efimova and et. al., 2017; Salakhova and et. al., 2016; Enyashina and et.al, 2017; Gnedova and et.al., 2015; Lipatova and et.al., 2015; Masalimova & Shaidullina, 2017; Mitin, 2014; Ovsyanik and et.al., 2016; Vasyakin et.al., 2015; Folomeeva, 2010).

Combinations of these factors often determine the types of trust of the population in reforms among which the following generalized forms types can be distinguished:

1. Trust, based on belief in «charismatic» leaders of the country. At the same time, personal understanding of the essence of reforms by many people can be weak (with inept and unconvincing propaganda of the reforms' meaning, with a low level of general culture and self-respect of the majority of the population). But this kind of trust can be quite effective if the belief in the leader is very high, and the leader himself demonstrates readiness for self-change.

2. Trust based on the reforms' success in other countries. The leader of a country should demonstrate solidarity with these countries, as well as the willingness to cooperate with them. The problem is that infrequently other countries have their own interests, and are not always ready to help unselfishly those who in the future can become their rivals. That is why, reckless and too gullible appeal to the examples and other countries' assistance, even if they have been successfully reformed, does not always turn out to be beneficial, as it happened during the reform of our country in the 90-s. Although, undoubtedly, valuable experience (and mistakes) of reforms in other countries is useful. It is only desirable to remember that the reforms of each country have their own specific features and not always someone else's experience can be blindly applied to Russian conditions.

3. Trust based on fear, when the authorities undertaking reforms are too persistent in making changes in the country and its economy. Under these conditions, those who disagree or resist reforms are often subjected to various sanctions (in more civilized forms they are dismissed from work, demoted, limited in rewards and benefits, etc.). It may seem paradoxical, but such persistence of the authorities can lead to certain successes, even if the reforms themselves and their goals are not fully thought out and are "thought out" in the process itself. With this type a part of the population may have special trust in such a "confident" leadership (belief in a "strong leader" - an important feature of the mass consciousness). But often such, in fact, directive reforms are accompanied, not always justified, by the "the tightening of the nuts", the struggle with the inconvenient people, and even real repressions (according to the principle, "the end justifies the means"). As a result, a part of the population (and often this is the thinking and doubting part) feels offended, and with time they become united, and can act as a strong opposition to the authorities and their reforms. Something similar happened with the reforms of the Soviet period, when on the basis of previous grievances, the important achievements were crossed out that were obtained at a heavy cost.

4. Trust based on deception. Both the masses and the leaders of the country can be deceived (for example, by trusting their not very competent or very self-interested experts). Infrequently, deception is achieved by the "effective" mass media, when only those representatives of the expert community ("full-



time intellectuals") are invited to "persuasive" TV and radio programs, who in every way justify the reforms of the authorities, and all other view points are either discredited or, in general, are hushed up. Usually in such "non-natural" discussions incorrect methods of communication are used: the speakers are interrupted, excessive pressure is exerted on the opponent, working "on the public" with spectacular intonations, pauses, smirks, etc., but not with arguments, logic and facts (Riseberg, 2012). If the viewers are not very developed intellectually, and especially - in terms of self-esteem, allow themselves to be manipulated, then such reasons for the reforms seem to be quite convincing for them. And then, even not well-thought socio-economic changes can initially be perceived with full confidence (the authorities usually promise improvements to some distant date). But then, deception is revealed and trust declines.

5. Trust based on understanding of the essence of reforms by a large part of the population of the country, which presupposes a preliminary and serious preparation of the population for the forthcoming reforms. This often involves diligent explanatory work with discussion in labor groups and in the mass media (through public discussions with the invitation of well-known and authoritative experts in various branches of public production). Even if the authorities are confident about reforms themselves, they should not make haste with the implementation of reforms, but should seek a gradual increase in trust in the social and economic changes of a large part of society. It should be noted that often even advanced ideas that were not supported by the majority of the population (not understood by the masses) are ineffective, as for example, with the Stolypin reforms, and with some reforms of the Soviet period when people were forcibly led to communism. An important role is played not only by the mass media, but also by scientists- experts, school teachers, and teachers of vocational schools. Accordingly, the government should back and promote journalists, scientists, teachers and university teachers who support reforms.

It is possible that too advanced reforms will be alien to the majority of the population, and then the authorities responsible should not deceive themselves and either inform about the benefits of these reforms to a large part of the population or even adjust the vector of economic development in accordance with the country's general cultural level. In this case, the authorities must admit that they suffered a certain educational and psychological defeat, and failed to "reach out" to the minds and hearts of the majority of the population. Accordingly, in the future, the authorities must draw conclusions and pay more attention to educational policy in terms of educating the masses and promoting advanced ideas of the country's economic and social development (Masalimova and et.al., 2014; Mitin, 2016; Salakhova and et.al., 2017; Folomeeva, 2010).

We think that it is the latter option that is most consistent with this high-tech society's ideals and, with a skillful implementation, can become an excellent guarantor of the reforms' effectiveness. It is important at the same time to take account of how different educational and age groups of the population perceive the reforms that are implemented, in particular, students and working specialists.

### Materials and Methods

The purpose of our study is to reveal the attitude (trust) to the reforms carried out by the authorities among students and working specialists, and also to devise recommendations to raise the degree of trust in the reforms in these population groups. We have put forward the hypothesis that there are certain differences in the attitude to reforms among students studying economic sciences and working specialists engaged in business. To achieve the goal and verify the hypothesis, we set ourselves more specific tasks: 1) to reveal the level of self-relationship among the studied groups (to assess the respondents' confidence in their assessments and their susceptibility to conformism); 2) to reveal readiness of the tested people for constructive cooperation; 3) to identify the dominant options of trust in reforms.

Seventy two respondents participated in the study: students and listeners of the Institute of short programs at Financial University. The age of respondents - from 18 to 40. All respondents were divided

conditionally into two groups: group 1 - students (the age of the tested students - 18 - 23) and group 2 - listeners – business representatives, employees of state and other institutions (the age of the tested people - 24-40).

In the course of the study the following means were used:

- 1) The technique of investigating self-relation by S.R. Panteleyev (MIS) (Panteleyev, 1993).
- 2) The personal questionnaire that represents a modified version of the five-factor personality questionnaire of McCrae and Costa (The Big Five) (McCrae, Paul Costa, 1987, Khromov, 2000), consisting of 30 pairs of stimulus sentences of opposite meaning which characterize behavior of an individual (Annenkova and et.al., 2017). Thus in our modification, each major factor consists of three primary factors. The modification of the questionnaire was carried out in order to study the influence of personal characteristics on the formation of public trust in economic reforms among various social groups of the population.
- 3) The author's questionnaire devised by us for determining the level of public trust of the population in economic reforms. This technique includes 25 questions that determine the type of trust (the totality of trust types) and the level (levels) of expression of the trust type. A six-point evaluation system was used. The technique includes five scales: "Trust based on belief in "charismatic leaders of the country", "Trust based on fear", "Trust based on deception", "Trust based on understanding the essence of reforms", "Trust, based on the success of reforms in other countries ", which are identified at three levels of severity: on a low, medium and high.

## Results

The results of the self-relation technique testify to medium values of respondents, except «Self-acceptance» (66,7 % of respondents), «Self-attachment» (61,1 % of respondents) and «Internal proneness to conflicts» (55,6 % of respondents), who are represented by lower values that testifies to a selective attitude of the respondents to themselves in which the emergence of difficulties is associated with the decline of confidence in oneself, and is characterized by the emotional state of anxiety and alarm. The extent of adaptation of the tested people determines their attitude to their personal «I», so under new circumstances their proneness to the influence of the people around increases. The obtained data testify to the respondents' selective perception of other people's attitude towards them, so the positive attitude of others is related only to certain qualities and deeds, while their other manifestations cause only irritation and rejection. Such indicators show the respondents' high assessment of their individual qualities, apparently recognizing their uniqueness, with a clear underestimation of other qualities. Thus the remarks of other people lead the representatives of this group to a sense of their own inferiority and, a sort of lesser value. In this case, the expression of anger and annoyance towards other people may be associated with the accusation of oneself for certain deeds and actions. According to the interpretation of the indicators, the respondents of this group do not have enough sympathy for themselves, they are distinguished by a general negative background of self-perception, a critical assessment of themselves. A negative assessment of oneself can manifest itself in various forms: from funny stories about oneself to self-abasement.

These techniques of studying self-relation testify to the prevalence of an average level of the respondents' self-confidence of the second group (69.4% of respondents), which characterizes the group's representatives as people who keep their working capacity in familiar situations, self-assured, oriented to success in their endeavors. They may have a decline in confidence and signs of anxiety in the face of difficulties. At the same time, they have a higher level of self-guidance (58.3% of respondents), since these tested people consider themselves to be the main regulator of their successes and achievements. Such people are able to control their emotional reactions and experiences. High values (8 stens - in 75% of respondents) on the scale "Reflected Self-Attitude" indicate that these people perceive themselves as

accepted by others, they feel that they are valued by other people for their personal qualities, for their actions. These respondents consider themselves to be sociable, able to establish business and personal contacts. For the majority of the subjects in this group, there are also high values (7-8 stens) on the scale of "Self-value" (80.6% of respondents), on the scale "Self-acceptance" (63.9% of respondents), on the scale "Self-attachment" (69.4 % of respondents), and low values (3 stens) on the scales of "Internal proneness to conflicts" (75% of respondents), and "Self-accusation" (69.4% of respondents). Thus the respondents of this group have a feeling of sympathy for themselves, they have a more positive attitude to themselves, they strive for changing some of their qualities.

The analysis of the diagnostics results of the respondents' personal characteristics in the first group showed the prevalence of high extroversion values (77.8% of respondents), and emotional instability (69.4% of respondents), combined with a medium one, with a tendency toward high attachment values, high self-control (63,9% of respondents), and high level of expressiveness (61.1% of respondents).

In other words, the representatives of the first group are sociable, are prone to risk, impulsive and thoughtless actions. They can be characterized by a quick temper and aggressiveness. According to the evaluation of personal characteristics, they tend to cooperate more than to compete, in the course of interaction with other people they try to avoid disagreements. Despite a sufficiently high level of volitional regulation, in stressful situations, as well as in case of failure, they can fall into despair because of a high level of emotional instability.

The results of the diagnostics of the personality characteristics in the second group showed that introverts (55,6% of respondents) predominate in this group, they are characterized by an average level of attachment (15 points), an average level of self-control (16 points), a high level of emotional stability (14 points) and medium level of practicality (20 points). Thus in general, this group can be described as the people who are less dependent on external conditions, carefully planning their future, weighing their actions, not trusting their first motives, strictly controlling their emotions, who are rarely unrestrained and excited. Such people have a quite positive attitude to others, they can understand another person, they are more likely to cooperate, but at the same time they are self-reliant enough and independent. They are more conscientious, responsible, obliging, they mainly can control their behavior. Representatives of this group are self-sufficient, confident in their abilities, not upset about minor troubles, they know their shortcomings. They are well adapted in everyday life, they look at life quite realistically, but at the same time show interest in various aspects of life.

The research results of the level of public trust of the population in economic reforms in the first group showed a predominance of medium and low levels of public trust in economic reforms. Fifty five point six percent of respondents are distinguished by a medium level of "trust based on belief in" charismatic "leaders of the country," 25% - low and 19,6% - high. Young people are less likely to have "trust based on fear," a low level of this kind of trust was found in 88.9% of respondents, the other respondents of the first group are characterized by a medium level. Respondents in this group are also less likely to have "trust based on deception," a low level is observed in 58.3% of respondents, a medium of 27,8%. The other respondents (13,9% - high level) allow themselves to be manipulated. Considering the indicator "Trust based on the understanding of the essence of reforms", it should be noted that a medium level is inherent in the younger respondents in this group (72,2% of respondents), which is also relevant to the indicator "Trust based on the success of reforms in other countries" (63,9% of respondents).

The research results of the level of public trust of the population in economic reforms in the second group also showed the predominance of medium and low values of the level of public trust in economic reforms. Fifty two point seven percent of respondents have an average level of "trust based on belief in" charismatic leaders of the country, 30,6% - low and 16,7% - high. Respondents of the second group more often "experience" "trust based on fear", 5,6% of the subjects of this group have a high level of this type of trust, 61,1% of respondents have a medium level, the other respondents of the second group (33,3%) are

characterized by a low level. "Trust based on deception" is inherent in respondents of this group more than in the first group, a low level is observed only in 47,2% of respondents, a medium - in 25%. The other respondents (27,8% - high level) allow themselves to be manipulated. Considering the indicator "Trust based on the understanding of the essence of reforms", it should be noted that older respondents represented in this group have a higher level (55,6% of respondents), which is also related to the indicator "Trust based on the success of reforms in other countries "(52,8% of respondents).

The statistical processing of the data with the use of the Pearson correlation coefficient revealed the relationship between "trust based on belief in" charismatic "leaders of the country" and extraversion and attachment (see the table). In other words, sociability, a significant number of acquaintances and friends, the enjoyment of entertainment, the need to be close to other people is connected with trust, due to a high level of authority of the reformer. Thus respondents with a high level of such trust are distinguished by people's understanding, tolerance, a desire for cooperation.

Table - Correlation values of trust and personal factors

	Extraversion	Attachment	Self-control	Emotional instability	Expressiveness
Trust based on belief in "charismatic" leaders of the country	0,4528 p≤0,01	0,5832 p≤0,01	-0,1261	-0,0861	0,1574
Trust based on fear	0,2566	0,1897	- 0,2543	0,5317 p≤0,01	01238
Trust based on deception	0,1862	0,0763	- 0,4873 p≤0,01	0,2327	0,1008
Trust based on success of the reforms in other countries	- 0,2387	- 0,1276	0,4967 p≤0,01	- 0,2538	- 0,1873
Trust based on the understanding of the essence of reforms	-0,1029	-0,1059	0,5725 p≤0,01	-0,1212	- 0,4924 p≤0,01

The relationship between emotional instability and "trust based on fear" has been revealed, that is, this kind of trust is more inherent in a person with a lack of sense of responsibility, losing touch with reality, feeling helpless, incapable of coping with life difficulties. There is an inversely proportional dependence of the level of "trust based on deception" and self-control indicators. Respondents who are characterized as conscientious, responsible, obliging, accurate and punctual in affairs are less likely to be manipulated.

Besides, there is an interrelationship between "trust based on the understanding of the essence of reforms", "trust based on the success of reforms in other countries" and self-control among the subjects participating in the study: higher levels of "trust based on the understanding of the essence of reforms" and "trust based on the success of reforms in other countries" are due to a high assessment of their capabilities, belief in their own strengths, their own value, significance, being needed, associated with integrity, responsibility, and commitment. Such respondents are distinguished by persistence in their activities and following moral principles (Masalimova & Chibakov, 2016; Mitin and et.al., 2017; Salakhova and et.al., 2017; Efimova and et.al., 2015; Folomeeva & Fedotova, 2016; Vasyakin and et.al., 2016).

The revealed inversely proportional relationship of "trust based on the understanding of the nature of reforms" and expressiveness is manifested in the fact that respondents with a more practical attitude to life and a preference for persistence and reliability are more prone to forming "trust based on the understanding of the essence of reforms".

### Discussions

The analysis of the concept of trust involves considering this phenomenon from the view point of different sciences.

One of the fundamental studies of trust in domestic literature belongs to A.B. Kupreichenko. A.B. Kupreichenko treats trust as a psychological attitude and distinguishes cognitive, emotional and behavioral components in the structure of trust (Kupreichenko, 2008). The cognitive component includes self-image, perception of the second participant in the trust relationship and interaction conditions as well as expectations associated with the partner's behavior. The emotional component includes the emotional attitude and evaluation of the parties and the process of interaction. The behavioral component is the readiness to act in a certain way in relation to a partner, himself and established conditions. As A.B. Kupreichenko writes: "trust as a psychological attitude includes interest and respect for the object or a partner; the idea of needs that can be met through interaction with him; emotions from anticipation of their satisfaction and positive emotional assessment of a partner; relaxation and unconditional willingness to show goodwill towards him as well as to perform certain actions that contribute to successful interaction" (Kupreichenko, 2008).

A similar study was conducted for the first time on students and graduates of the Financial University under the Government of the Russian Federation. We thought that the effectiveness of the reforms will be high.

Trust can be represented as an attitude, a mindset, a feeling, a state, a process of the information transmission and a social exchange, the competence of an individual, mood, a social attitude, a social problem as well as a personal and group property, the form of personality orientation (Kamneva, Polevaya, Annenkova, 2016).

Thus trust should be more attributed to the emotional sphere of the human psyche, that is, to a psychic sphere that is characterized by irrationality and is poorly rationalized (Belyanin, 2010), being a basic feeling capable of arousing many other feelings (from love to hatred), psychological conditions (from comfort to stress and frustration) and social attitudes (from acceptance to rejection).

In modern studies of public trust, an increasing emphasis is placed on individual mental states of people and the generalized expectation of improvements in the economy and in their lives. Many authors distinguish such trust-expectation from a person's confidence in the stability of their lives and optimistic prospects (Skripkina, 1998; Baier, 1986; Herizberg, 1988; Rosenberg, 1979; DeWaal, 1996).

It should also be noted that such a study was conducted for the first time among students and graduates of the Financial University affiliated to the Government of the Russian Federation and we had reason to believe that the degree of approval of the ongoing reforms would be quite high.

The study of trust is often conducted in the framework of self-presentation and self-representations of a person, reflecting the group membership, solidarity with reference groups, which is often the basis for the identity of an individual and his willingness to reconcile his ideas with that of social groups to which the person relates himself (Sanders, 2001; Landa, 1994; Hewitt, 1998). It is also pointed out that the level of public trust in reforms in Russia has significantly decreased over recent decades (Dankin, 2006; Kuznetsov, 2003).

The specific feature of our research is the comparison of the level of trust in specific groups of students doing courses in economic sciences, who are trained in the program "personnel manager" and specialists who are working - business representatives, employees of state and other institutions. An important feature of these groups is that in view of their education they are more competent in the economy management than many other groups of the population. It should also be noted that a similar study has been conducted for the first time among students and graduates of the Financial University under the Government of the Russian Federation and we had grounds to believe that the degree of approval of the ongoing reforms would be quite high.

We have already presented detailed research results in view of which we can draw interesting conclusions:

1. Both students and working specialists have a general level of trust in reforms at low and medium levels which testifies to a lack of personal acceptance of reforms and a pessimistic attitude to the opportunity to actively participate in these reforms.

2. At the same time, students have a less pronounced "trust based on deception" than that of working specialists, i.e. the students' trust is based more on "understanding the essence of reforms", whereas "trust based on deception" is more typical of working specialists. Our interpretation of these interesting results: 1) students listen more to bold and qualified teachers and this boldness is transmitted to the students themselves, and working specialists are more burdened by their business affairs; 2) the life position of students is more protected, and working specialists have many career risks in business and in government institutions where too bold speaking one's mind is not always positively perceived by the administration; 3) the belief dominates among working specialists that "it is necessary to do business, not criticism," while students are still dominated by a more critical (and meaningful) attitude to any innovation ...

3. At the same time, students have less expressed indicators of self-acceptance and self-confidence than working specialists, which at first glance should be contrary to their bolder reform evaluations and an orientation to trust, "based on an understanding of the essence of reforms" (see the previous point of conclusions). We have the following interpretation of this: 1) with a more expressed critical attitude to understanding what is happening in the economy, it can be assumed that such a critical attitude is transferred onto the student's personality, turning into excessive self-criticism; 2) In addition, a more critical attitude to the current reforms in the country makes many students feel less optimistic about their professional future after their graduation from the university, whereas in specialists who are working already the career situation has some certainty and even stability.

## Conclusion

Thus our hypothesis about the differences in trust in the reforms of the authorities was confirmed partially. Both students and working professionals did not have any significant differences in their trust in the reforms (in both groups, trust was at the low and medium levels). But the very trust in the reformers (the executive power that conducts reforms) is different: among students this trust is mainly

based on their desire to understand the essence of reforms, but working professionals are more prone to manipulation and their trust is more based on their willingness to be "deceived."

Accordingly, this should be taken into account in the activities aimed at increasing the level of trust in the authorities that undertake reforms. Our research shows that even against the background of general lack of trust in the reforms, there are all quite subtle differences not only among different social groups of the population, but also among people doing different courses and working in different spheres of the economy. It is clear that it is necessary to continue similar studies, in which it is important not only to ascertain the existing level of trust, but also to predict its change. It is much better yet, to positively influence somehow the dynamics of trust in the direction of its increase and the engagement of ever larger masses of the population in creative activity for the common good.

### Recommendations.

Based on the results of the study, we can make specific recommendations to increase the level of trust among students and professionals related to the economy, business and management. Accordingly, our recommendations are more intended for the executives of educational institutions (not only higher and secondary professional, but also school), as well as for managers of business structures and state agencies.

1. If possible, one should study attitudes towards the reforms in educational and work groupings in order to take account of both the specifics of educational courses and programs, the specificity of activity in further work with students and staff.
2. To raise trust, "based on an understanding of the essence of reforms," to hold specially organized events aimed at bold discussion in the teams of both controversial and successful examples of the economic reforms' implementation. At the same time, this work is more relevant for working specialists. The very form of such events should not be "a box-ticking approach" (for a show), and for this it is better to use such well-proven methods as "round tables" (with the invitation of leading scientists), discussions, focus groups, business games and so on. We can assume that such informal discussions and debates can increase the level of self-acceptance and self-esteem of participants, which is especially important already for students, many of whom still feel insecure by the time they graduate from a higher education institution and at the beginning of their employment.
3. To raise trust in the reforms, the emphasis should be shifted from purely economic aspects, often oriented to primitively understood "advantage" and "profits" - to the moral advantages of the reforms carried out by the authorities, and also to refresh the problems in the minds of the participants that prevent even the active and talented people from realizing themselves fully for the common good. It is in this reorientation of the emphasis that the prospect of a more full-fledged personal development lies for students as future transformers of the country and working specialists as real figures, many of whom will sooner or later start thinking about their contribution to the rebirth of Russia.

### References

- Annenkova, N.B., Kamneva E.V., Polevaya, M.V., Buyanova, S.M., Gagarina, M.A., Korobanova, Zh.V., Lebedev, A.N., Malsagova, K.B., Muzhichkova, Yu.E., Smurygin, A.A. (2017). Moscow: SVIVT.
- Baier, A. (1986). Trust and Anti-trust. *II Ethics*, 2 (96), 231-260.
- Belyanin, A.V. (2010). Trust in the economy and public life. Moscow: Foundation "Liberal Mission".
- Borokhov, E.V. (1998). Encyclopedia of aphorisms (Thought in a word). Moscow: AST.
- Dankin, D.M. (2006). The basic element of the architecture of the world. On the role of trust in the model of the future world order. *The Security of Eurasia*, 4, 91-107.
- De Waal F., 1996. Good Natured: The Origins of Right and Wrong in Humans and Other Animals (Cambridge: Harvard University Press).

- Efimova, O.I., Salakhova, V.B., Mikhaylova I.V., Gnedova, S.B., Chertushkina, T.A. & Agadzhanova, E.R. (2015). Theoretical review of scientific approaches to understanding crisis psychology. *Mediterranean Journal of Social Sciences*, 2, 3-11.
- Efimova, O.I., Oshchepkov, A.A., Chirkovskaya, E.G., Klepach, Y.V., Gridyaeva, L.N. (2017). The Experience of Studying Specific Features of Social Attitudes and Value Orientations among Normative and Deviant Teenagers. *Eurasian Journal of Analytical Chemistry*, 7b, 12, 1549-1553.
- Enyashina, N.G., Gridneva, S.V., Khudyakova, T.L., Gridyaeva, L.N., Pozharskay, E.L., Deberdeeva, N.A. (2017). Development of Higher Education Students' Creative Abilities in Learning and Research. *Eurasian Journal of Analytical Chemistry*, 5b: 753-763.
- Folomeeva, T.V., Fedotova, S.V. (2016). The Phenomenon of Social Status in Contemporary Russian Society. *Psychological Research (electronic journal)*, 9 (48), 7.
- Folomeeva, T.V. (2010). Dynamics of consumer attitudes in conditions of socio-economic changes. *National Psychological Journal*, 3 (1), 111-117.
- Folomeeva, T.V. (2010). Role of socio-economic changes in the development of consumer attitudes. *Russian scientific journal*, 17 (4), 166-184.
- Gnedova, S.B., Emelyanenkova A.V., Mikhailova I.V., Sedunova A.S., Enyashina N.G., Salakhova, V.B (2015). Individual Characteristics of Students in the Course of Professional Development (as Exemplified by the Ulyanovsk Region of Russia), *Asian Social Science*, 11(3), 168-176.
- Herizberg, L. (1988). On the Attitude of Trust. *II Inquiry*, 31, 307-322.
- Hewitt, C. (1998). The Role of Scholars in the Abkhazians' Loss of Trust in the Georgians and how to Remedy the Situation. *Caucasus: War and Peace*.
- José Ortega y Gasset (1998). *Rebellion of the masses. Psychology of the masses. Reader*. Samara: BAKHRAH.
- Kamneva E.V., Plevaya, M.V., Annenkova N.B. (2016). Trust to business partners is a psychological aspect. *Alma mater (Herald of Higher School)*, 11, 26-31.
- Khromov, A.B. (2000). *Five-factor questionnaire personality: Teaching-methodical manual*. Kurgan: Publishing house of the Kurgan State University.
- Kupreichenko, A.B. (2008). *Psychology of trust and distrust*. Moscow: Publishing house "Institute of Psychology of the Russian Academy of Sciences".
- Kuznetsov, V.N. (2003). *Geoculture: The fundamentals of the geocultural dynamics of security in the world of the XXI century*. Moscow: Culture-Network.
- Landa, J.T. (1994). *Trust, Ethnicity and Identity: Beyond the New Institutional Economics of Ethnic Trading Networks, Contract Law and Gift-Exchange*. Ann Arbor: University of Michigan Press.
- Lebon, G. (1995). *Psychology of the peoples and the masses*. St. Petersburg: Layout.
- Lipatova, N.V., Salakhova, V.B., Chertushkina, T.A., Ermolayeva, S.V., Mikhaylova, I.V., Shrol, O.Y., Panteleev, S.V. (2015). An adaptive man: hardiness resources in the conditions of system crises at the turn of the xix-xx and the xx-xxi centuries. *Mediterranean Journal of Social Sciences*, 6. (2) S3, 136-141.
- Masalimova, A.R. & Shaidullina, A.R. (2017). Diversification of Professional On-the-Job Training Models and Forms in Contemporary Business Conditions. *Modern Journal of Language Teaching Methods*, 7(3), 554-561.
- Masalimova, A.R., Chibakov, A.S. (2016). Experimental analytical model of conditions and quality control of vocational training of workers and specialists. *Mathematics Education*, 11 (6): 1796-1808.
- Masalimova, A.R., Schepkina, N.K., Leifa, A.V., Shaidullina, A.R., Burdukovskaya, E.A. (2014). Mentoring perfection in modern enterprises conditions: practical recommendations. *American Journal of Applied Sciences*, 11(7), 1152-1156.
- McCrae, R.R., and Costa, P.T. (1987). Validation of the five - factor model of personality across instruments and observers. *Journal of Personality and Social Psychology*, 52, 81-90.
- Mitin, S.N. (2014). System-synergetic approach as a basis of work of the expert working with youth.



- Simbirsk Scientific Bulletin*, 3(17), 44-49.
- Mitin, S.N. (2016). Psychotherapeutic approach in the management of the development of educational systems. *Simbirsk Scientific Bulletin*, 4(26), 31-39.
- Mitin, S.N., Belinskaya, D. B., Vasyakin, B.S., Kamneva, E.V., Lipatova, N.V. (2017). A socio-economic approach in studying key types of the personality's viability. *Modern Journal of Language Teaching Methods*, 5: 18-28.
- Ovsyanik, O.A., Belinskaya, D.B., Kochetkov, I.G., Deberdeeva, N.A. (2016). 'Specific Features of Value Orientations and Social Mindsets of Deviant Teenagers'. *International journal of environmental & science education*, 11(18): 12327-12336.
- Panteleyev, S.R. (1993). Methodology of the study of self-relationship. Moscow: Sense.
- Pryazhnikov, N.S. (2011). The Star Hour and Prospects for the Development of the «Little Man». *Bulletin of the Moscow University. Psychology*, 2, 126-134.
- Reich, W. (2004). Psychology of the masses and fascism. Moscow: AST.
- Riseberg, B.A. (2012). Modern problems of strategic management of the Russian economy. *Collection of scientific papers IMEI*, 1, 7-33.
- Rosenberg, M. (1979). Conceiving the self. New York: Basic Books.
- Salakhova, V.B., Bulgakov, A.V., Sokolovskaya, I.E., Khammatova, R.S. and Mikhaylovsky, M.N. (2016). Substantive (Content-Related) Characteristics of Deviant Behavior as a Social and Psychological Phenomenon. *International Journal Of Environmental & Science Education*, 11(17), 10609-10622.
- Salakhova, V.B., Kalinina, N.V., Belinskaya, D.B., Aygumova, Z.I. and Tkhuogo, M.M. (2017). Education as a factor of raising the adaptation potential in a delinquent personality. *Man In India*, 97(3), 1-13.
- Salakhova, V.B., Lodzhanidze, A.A., Vasyakin, B.S., Sidyacheva, N.V., Ludvig, S.D. (2016). Dynamic Meaning Systems of Consciousness of a Criminal Personality. *International Journal of Environmental & Science Education*, 11(16), 9374-9380.
- Salakhova, V.B., Oschepkov A.A., Lipatova N.V., Popov P.V. & Mkrtumova I.V. (2016). Features of Social Attitudes and Value Orientations of Youths and Adolescents Prone to Auto-Aggressive Behavior. *International Journal Of Environmental & Science Education*, 11(16), 9017-9025.
- Salakhova, V.B., Ovsyanik, O.A., Shmeleva, N.B., Lvova, E.N. & Shabanova, O.V. (2016). The Problem of Higher Education in the Executive System of Russian Government. *International Journal Of Environmental & Science Education*, 11(4), 9883-9889.
- Salakhova, V.B., Tashcheva, A.I., Gridneva, S.V., Zhmurin, I.E., Mikhaylovsky, M.N. (2017). Experimental study of social and psychological correction of the teenage personality's values and motivation sphere who is prone to deviant behavior. *Modern Journal of Language Teaching Methods (MJLTM)*, 7(4), 12-20.
- Sanders, N.V. (2001). Trust in Ethnic Ties: Social Capital and Immigrants I Cook K. (ed.). Trust and Society. New York: Russell Sage Foundation.
- Skripkina, T.P. (1998). Methodological analysis of the problem of trust. *Applied psychology*, 1, 50.
- Vasyakin, B.S., Berezhnaya M.S., Pozharskaya, E.L., N.A. Deberdeeva (2015). Adaptation of graduates and students of regions to education in higher education institutions of Russia by means of social-psychological training. *Review of European Studies*, 7(3): 88-89.
- Vasyakin, B.S., Ivleva, M.I., Pozharskaya, E.L., Shcherbakova, O.I. (2016). 'A Study of the Organizational Culture at a Higher Education Institution (Case Study: Plekhanov Russian University of Economics (PRUE))'. *International Journal of Environmental and Science Education*, 11(18): 11515-11528.
- Vygotsky, L.S. (2010). Pedology and Psychotechnics. *Cultural-historical psychology*, 2, 105-120.

## Psychological And Pedagogical Support Of Parents In Developing Social Adaptation Resources In Inclusive Education Participant

Svetlana V. Gridneva <sup>1</sup>, Yuri A. Bubnov <sup>2</sup>, Tatiana A. Dronova <sup>3</sup>, Oksana V. Shabanova <sup>4</sup>,  
Svetlana N. Kazakova <sup>5</sup> & Ludmila N. Gridyaeva <sup>6</sup>

<sup>1</sup>Department of General and Pedagogical Psychology of the Academy of Psychology and Pedagogy of the Southern Federal University, Rostov-on-Don, Russia.

<sup>2</sup> Faculty of Philosophy and Psychology, Voronezh State University, Voronezh, Russia.

<sup>3</sup> Faculty of Philosophy and Psychology, Voronezh State University, Voronezh, Russia.

<sup>4</sup> Faculty of Humanities, Ulyanovsk State University, Ulyanovsk, Russia.

<sup>5</sup> The Department of management of nursing activities and social work, The Sechenov First Moscow State Medical University, Moscow, Russia.

<sup>6</sup> Department of Practical Psychology, Voronezh State Pedagogical University, Voronezh, Russia.

### Abstract

The process of social adaptation is treated from the point of view of overcoming difficult situations. It has been proved in the article that the key place in developing a child's skills of overcoming the difficulties belongs to the family where the conditions are formed either to consolidate non-constructive psychological defense mechanisms or to develop constructive strategies of overcoming difficult situations. The development of the ways of overcoming the difficulties is determined by the type of interaction between parents and a child. It has been proved that the organization of support for interaction between parents and a child in a family contributes to social adaptation. The experience of providing supportive interaction between parents and children – participants of the inclusive educational environment in the framework of special classes of the family interaction club has been presented. The materials of the article can be useful for reforming, educational activity of a teacher-psychologist, in giving consultation to parents of inclusive education participants as well as in training programs development and correction programs.

**Keywords:** adaptation resources, inclusive education participants, supportive family interaction, difficult situation, an overcoming strategy.

### Introduction

At present putting inclusive education into practice at general education institutions is one of the tendencies in education. The concept of inclusion in contemporary education is understood as the major factor of providing the right to education for everyone including the children with limited abilities (Dronova & Dronov, 2017; Efimova et. al., 2017; Bubnov, 2008; Kalinina & Kalinin, 2016; Kovaleva, 2015; Salakhova et. al., 2016).

The concept «inclusion» itself was introduced as early as at the end of the XX century in many developed countries of the world (USA, Great Britain, Sweden, Germany, Scandinavian countries). At that time by this concept the society understood integrated education in which assistance, support are provided and additional special conditions are created for the children with limited abilities involved in the general education process for the purpose of making learning easier.

At the World Conference on Education for All held in Jomtien an issue was raised for the first time - about the number of children excluded from school life as well as about the necessity of introducing more inclusive approaches to education for the purpose of overcoming the barriers that arise before the children whose needs at this time were not satisfied. In the «standard regulations to provide equal opportunities for the disabled people» adopted afterwards by the UNO in 1993 a call was formulated to ensure education for people in the integrated structures or assisting in it to make education for children with limited abilities as an inseparable part of the education system.

In 1994 the Salamanca declaration and UNESCO Framework for Action, which were signed by the governments of 92 countries, confirmed and reinforced these provisions by the direct call for the development of inclusive education. The principle was also formulated in these documents: schools must provide equal opportunities for every child's comprehensive development irrespective of his place of residence, sex, nations, language, social status, psychophysical and other specific features (also children with limited abilities). The committee for the rights of the child identified the necessity of actions to eradicate segregation in the sphere of education in the course of holding General Discussion Day in 1997. This event was dedicated to the rights of the child with limited abilities which provided a recommendation: «The states should review and change their laws that are connected with children with limited abilities and incompatible with the principles and provisions of the Convention on the Rights of the Child (CRC), for example legislation which leads to compulsory segregation of children with limited abilities at some institutions for the purpose of providing care, treatment and learning» (Convention on the Rights of Persons with Disabilities).

At present inclusive education in the Russian Federation is regulated by the RF Constitution, the Federal Law on «Education», Federal Law on «Social protection of disabled people in the RF» as well as the Convention on the Rights of the Child and Protocol No1 of the European Convention on the Human Rights Protection and main freedoms.

Since January 1, 2014 the Federal State Educational Standard has come into effect (FSES) (the order of the Ministry of Education and Science of Russia dated by 17.10.2013 No 1155), which clearly highlights the necessity of leveling out the initial opportunities for the children of pre-school educational institutions including the children with limited abilities. The Federal State Standard of Education makes provision for the program of corrective work which should be directed towards compensation of shortcomings in physical and psychic development and providing the children with assistance in mastering the main curriculum (Convention on the Rights of Persons with Disabilities).

The successful formation of inclusive culture at an educational institution is an indispensable part of socialization and integration of children with limited abilities into society.

The implementation of this important task of inclusive education – the task of assisting in social adaptation of all the children without any exception requires the search for new conditions and opportunities to build interaction between the participants of the educational environment. The situation of involving the learners in the inclusive educational environment which the children of limited abilities and without any health limitations find themselves in, poses a great number of difficulties and updates the necessity to develop and open the resources to overcome such difficulties. We treat a social situation created by adults around as a decisive condition to develop the adaptation resources in the traditions of domestic psychology. The process of development is treated by us in the context of life situations that replace each other in the course of life which contributes to deeper and more holistic perception about the processes of personal development and also of a person's self-realization. Thus the development of the personality in life situations is understood as an internal mechanism of the adaptation mechanism of the personality. Such an approach makes both the search for the personality's internal resources and simultaneous development of these resources possible in a social situation (Efimova et.al., 2015; Enyashina et.al, 2017; Bubnov, 2010; Gnedova et.al., 2015; Dronova, 2017; Kalinina et.al., 2016; Kovaleva, 2016; Leontev, 2017; Lipatova et.al., 2015; Salakhova et.al., 2017; Volosovets, 2011).

When the child faces the difficulties of the environment from the beginning of his life at first he has to adapt to such conditions and with age – to socialize in society. From the birth the child encounters the situations that bring dissatisfaction, in which he experiences stress, anxiety and even fear. Anxiety is distinguished as an emotional state (situational alarm) and anxiety as a stable trait, an individual's psychological feature that is manifested in an inclination to frequent and intensive experiences of the state of alarm. Alarm as a signal about the danger is necessary for a person's optimal adaptation to

reality. The presence of anxiety as a stable complex is an evidence of disorders in the personal development. There are two aspects in the realization of psychological adaptation. The first one is connected with purposeful actions which make it possible to change the situation or get out of it having met the needs in other conditions. At the same time the established system of needs is not changing (allopsychic or heteroplastic adaptation). On the other hand, the non-conformity between actual needs and opportunities of their meeting can be diminished or eliminated at the expense of the needs transformation system – this is the process of intrapsychic (autoplastic) adaptation. Intrapsychic adaptation is realized with participation of psychological defense mechanisms that allow one to eliminate or diminish alarm by way of changing the perception and assessment of the situation in which it arises. As the children start to be aware of their behavior, psychological defense mechanisms and unconscious behavioral reactions to alarm and stress can be transformed into the strategies of behavior used in various situations. The earlier the child will learn to be aware of his behavior and match it to certain situations, the more efficient he can be in adapting to new conditions and more stable he will be to both everyday difficulties and difficult life situation on the whole. The key place in developing the skills of overcoming the difficulties belongs to the family where the conditions are formed either to consolidate non-constructive psychological defense mechanisms or to develop constructive strategies of overcoming hardships. The development of the variants of overcoming hardships here is determined by the type of interaction between parents and a child. If the interaction with the child from the parents bears the character of «protection» when all these difficulties are overcome by them «for the child», then non-constructive strategies of overcoming are consolidated in the child. The organization of supportive interaction of the parents with the child in the family contributes to the development of social adaptation resources. We treat supportive interaction as the parents' interaction with the child directed towards the support in recognizing and overcoming difficult situations by them (Bubnov et.al., 2017; Kalinina et.al., 2017; Kovaleva, 2016; Masalimova & Shaidullina, 2017; Mitin, 2014; Ovsyanik et.al., 2016; Salakhova et.al., 2016; Vasyakin et.al., 2015).

### Methodological Framework

To implement this task in the study of supportive interaction between parents and children – the participants of the inclusive educational environment we undertook the attempt of providing supportive interaction between parents and children – the participants of inclusive educational environment in the framework of special classes of the family interaction club. Joint work between parents and children of junior school age, the participants of the inclusive educational environment is organized at the classes of the club.

In the course of the classes the following objectives are solved:

- understanding the situations by the child recognized as difficult ones;
- the child's understanding his behavior in the situations recognized as difficult ones;
- the parents' understanding the situations recognized by the child as difficult;
- the parents' understanding the child's behavior in difficult situations for him.

Children in turns answer the questions at classes:

1. What situations cause tension, and are not pleasant for you?
2. Why are they not pleasant for you?

Participants sit down in a circle, children and parents sit with their backs to one another. Then the leader asks children and parents to draw the so-called «behavior suns». Children write «I» in the center of the «sun», and parents – «My child». A way of behavior is written on every ray in difficult situations

(children write their own ways of behavior, parents recollect and write the ways of behavior for their children). After doing this task the leader asks the pairs to compare their «suns». While discussing the results of the task children are asked the following questions:

1. What ways of behavior did you write?
2. What usually happens as a result of such behavior?
3. What would you like to achieve with this way of behavior?
4. What do you think we can reach a result with another way?

Parents answer the following questions:

1. Did your «suns» coincide with your child's?
2. What do you think why they differ?
3. How would you like your child to behave?
4. What do you think you need to do for it?

In the course of classes the children identify the situations that cause difficulties and behavior in them, they get experience of resolving such situations in a group. The parents learn much better about their children's emotional experiences and come to a conclusion that they can exert influence on the children's behavior. Further, difficult situations are picked that are frequently mentioned by junior school students (it is important to trace that only those situations should be picked that are mentioned as difficult by both the children with limited abilities and children without any health impairments) for discussion of the variants of their overcoming. Some situations are acted out, and which is more important that both children and parents can play the role of a child. The most difficult situations for resolution, negatively emotionally colored ones are acted out with the help of puppets. Children and adults in turns offer their variants of resolution and thus «the bank of resolving difficult situations» is created. Every offered way of resolution is discussed in the group from the point of view of effectiveness, the difficulty in the execution and benefit for further relations with people (Masalimova et.al., 2014; Kovaleva, 2017; Mitin, 2016; Salakhova et.al., 2016).

## Results

The experience of providing supportive interaction between the parents and children in the framework of activity of the family interaction club shows a wide range of its opportunities in the development of adaptation resources of children: it enriches the experience of overcoming the difficulties, develops constructive skills of behavior in difficult situations, allows one to cohere parents and children – the participants of the inclusive educational environment, to melt away fears and doubts of the parents whose children were involved in inclusive education about its effectiveness, it raises tolerance and aspiration to constructive interaction with all the participants of the inclusive educational environment. The provision of its content and methodological support is the prospect of out further work.

Humanistic tendencies in the development of our society highlight the problem of the search for new approaches to learning, upbringing and development of children with limited abilities. Unfortunately, today more and more children are becoming health-impaired with various limitations in their health. Upbringing the children with limited abilities complicates the adaptation of families not only in a social and economic aspect but affects other spheres of their life.

Multiple studies show that social and psychological problems become significant problems for the families with children that have health impairments, i.e. the problems of finding one's place in life, sociability, interaction with the world and people in this world. The family finds it difficult to learn and teach a special needs child how to use the ways of social adaptation. The family more often takes a «protective attitude» to the child, adults intend to protect the child from difficult situations that leads to the development of egoistic position and inhibits the processes of the child's socialization.

Thus the development of social adaptation processes from the perspective of adaptive resources and opportunities, the child's active participation in the process of overcoming the difficulties seems to be very significant. Social and psychological as well as psychological and pedagogical assistance should be directed towards the support of the child in overcoming difficult situations. It should be directed to helping them understand what is important to them in life, to sort oneself out, to identify and build up resources to overcome the difficulties.

Personal and social resources represent a greater significance for social adaptation of a child with limited abilities which are used to overcome difficult situations. We can call successful adaptation of such a child the state when he is accepted in society, when he has certain achievements that are significant for himself and recognized in society, when the difficulties encountered on the way of achievements are viewed as those that can be surmounted. This is possible thanks to the formation of personal qualities, strategies of overcoming difficult situations and social support.

Personal and social resources are the most significant ones among adaptive resources. Social resources are viewed as personal specific features of an individual with the use of such strategies of behavior in difficult situations where the support of society is required.

Thus adaptive resources are the personality's abilities and capacities in achieving success in life which provide social adaptation and constructive interaction with members of society who make up a significant network of a person.

The results of the study conducted by us show that the organization of supportive interaction between parents and children in the framework of the family interaction club is an effective method of developing adaptive resources of children (Masalimova & Chibakov, 2016; Mitin et.al., 2017; Salakhova et.al., 2017).

### **Conclusion.**

The provision of the right of children with limited abilities to education is a strategic objective of the state policy in the field of education. The acquisition of high-quality education by such children is the main and inseparable condition of successful socialization and full-fledged participation in the life of society as well as effective self-realization in various types of activity.

Inclusion is at the beginning of its path at the contemporary stage of the Russian education development. To make the process of forming inclusive culture in an educational institution effective it is necessary to take into account the fact that the parents more often become the initiators of inclusive education in an institution. That is why the organization of support and interaction with parents is the objective of all the services: medical, social as well as the system of education from the beginning a child's life.

Every child is accepted and considered as an important member of the group at an educational institution where inclusion is implemented. This gives a special needs child and his parents self-confidence and encourages tolerance in children with normal development.

A special needs child should be supported not only by peers but other participants of educational relations to satisfy his special educational needs. These practices work out of persuasion that the

difference between people is a normal phenomenon and that the process of development must be adjusted to the needs of a child but not the child should adjust himself to surrounding conditions.

For a favorable development of inclusive education in an educational institution it is required to think well and organize the events that contribute to effective interaction between the participants of educational relations. While arranging the events it is required to take into account the following support mechanisms for the parents and assist in the growth of their participation:

- informative programs for parents to help them support the children directly in their educational activity;
- recognition and respectful attitude to the parents as specialists who know and understand their children;
- gradual involvement of the parents in the process of preparing the children for school;
- it is important to recognize the parents' experience and knowledge about the condition of their child and treat their experience and knowledge in a respectful way.

## References

1. Bubnov, Yu.A. (2008). Philosophical and methodological foundations of health-saving education. Problems of the health of students and students. New scientific trends in medicine and pharmacy. Voronezh: Voronezh State University.
2. Bubnov, Yu.A. (2010). Heuristic educational environment in a historical retrospective. Philosophical and psychological-pedagogical problems of the development of the educational environment in modern conditions. Voronezh: IPC Voronezh State University.
3. Bubnov, Yu.A., Endovitsky, DA, Bubnov, Yu.A., Gaidar, KM. (2017). Actual problems of education of youth in modern Russia. *Bulletin of Voronezh State University*, 2, 5-11.
4. Convention on the Rights of Persons with Disabilities [Electronic resource]. – Mode Access: [http://www.un.org/en/documents/decl\\_conv/conventions/disability.shtml](http://www.un.org/en/documents/decl_conv/conventions/disability.shtml)
5. Dronova, TA, Dronov, AA (2017). Tolerance from the position of value attitude to man. *Scientific and theoretical journal of the Russian Academy of Education*, 3, 33-37.
6. Dronova, T.A. (2017). Deidealization or transformation of the educational ideal. *Bulletin of Voronezh State University*, 3, 28-33.
7. Efimova, O.I., Oshchepkov, A.A., Chirkovskaya, E.G., Klepach, Y.V., Gridyaeva, L.N. (2017). The Experience of Studying Specific Features of Social Attitudes and Value Orientations among Normative and Deviant Teenagers. *Eurasian Journal of Analytical Chemistry*, 7b, 12, 1549-1553.
8. Efimova, O.I., Salakhova, V.B., Mikhaylova I.V., Gnedova, S.B., Chertushkina, T.A. & Agadzhanova, E.R. (2015). Theoretical review of scientific approaches to understanding crisis psychology. *Mediterranean Journal of Social Sciences*, 2, 3-11.
9. Enyashina, N.G., Gridneva, S.V., Khudyakova, T.L., Gridyaeva, L.N., Pozharskay, E.L., Deberdeeva, N.A. (2017). Development of Higher Education Students' Creative Abilities in Learning and Research. *Eurasian Journal of Analytical Chemistry*, 5b: 753–763.
10. Gnedova, S.B., Emelyanenkova A.V., Mikhailova I.V., Sedunova A.S., Enyashina N.G., Salakhova, V.B (2015). Individual Characteristics of Students in the Course of Professional Development (as Exemplified by the Ulyanovsk Region of Russia), *Asian Social Science*, 11(3), 168-176.
11. Kalinina, N.V., Kalinin, I.V. (2016). Social adaptation of school children in an inclusive school: resources and opportunities. *Society: Sociology, Psychology, Pedagogy*, 5, 34-36.

12. Kalinina, N.V., Kalinin, I.V., Salakhova, V.B., Oschepkov, A.A. & Simanovskaja, M.A. (2016). The Use of Social Resources of Inclusive Educational Environment to Cope Difficult Situations by Adolescents. *IEJME-Mathematics Education*, 11(7), 2527-2536.
13. Kalinina, N.V., Salakhova, V.B., Artamonova, E.G, Efimova O.I., Kalinin, I.V. (2017). Psychological Prevention Mechanisms of Minors' Deviant Behavior. *Eurasian Journal of Analytical Chemistry*, 12 (Special Issue):663-672
14. Kovaleva, N.B. (2015). Youth forum: designing a professional and personal future. University Saturdays at MPGU. Moscow: Moscow Pedagogical State University.
15. Kovaleva, N.B. (2016). Freedom of choice and self-determination of students in educational programs of personal development. *Problems of modern education*, 3, 59-65.
16. Kovaleva, N.B. (2016). Reflexive-positional solutions for the development of creative professionalism of teachers. *Psychology: Historical and critical reviews and modern research*, 3, 49-65.
17. Kovaleva, N.B. (2017). Media education prospects of reflexive-positional development of the personality and abilities of students. *Media Education*, 1, 9-25.
18. Leontev M.G. Impact of organizational culture, satisfaction of employees and students on the quality of education in University of Civil Engineering // International Science Conference SPbWOSCE-2016 "SMART City". MATEC Web Conf., 106 (2017).
19. Leontev, M.G. (2017). Impact of the work in small groups on the educational process in the University of Civil Engineering. International Science Conference SPb WOSCE-2016 "SMART City". MATEC Web Conf., 106 (2017)
20. Lipatova, N.V. Salakhova, V.B., Chertushkina, T.A., Ermolayeva, S.V., Mikhaylova, I.V., Shrol, O.Y., Panteleev, S.V. (2015). An adaptive man: hardiness resources in the conditions of system crises at the turn of the xix-xx and the xx-xxi centuries. *Mediterranean Journal of Social Sciences*, 6. (2) S3, 136-141.
21. Masalimova, A.R. & Shaidullina, A.R. (2017). Diversification of Professional On-the-Job Training Models and Forms in Contemporary Business Conditions. *Modern Journal of Language Teaching Methods*, 7(3), 554-561.
22. Masalimova, A.R., Chibakov, A.S. (2016). Experimental analytical model of conditions and quality control of vocational training of workers and specialists. *Mathematics Education*, 11 (6): 1796-1808.
23. Masalimova, A.R., Schepkina, N.K., Leifa, A.V., Shaidullina, A.R., Burdukovskaya, E.A. (2014). Mentoring perfection in modern enterprises conditions: practical recommendations. *American Journal of Applied Sciences*, 11(7), 1152-1156.
24. Mitin, S.N. (2014). System-synergetic approach as a basis of work of the expert working with youth. *Simbirsk Scientific Bulletin*, 3(17), 44-49.
25. Mitin, S.N. (2016). Psychotherapeutic approach in the management of the development of educational systems. *Simbirsk Scientific Bulletin*, 4(26), 31-39.
26. Mitin, S.N., Belinskaya, D. B., Vasyakin, B.S., Kamneva, E.V., Lipatova, N.V. (2017). A socionomic approach in studying key types of the peronality's viability. *Modern Journal of Language Teaching Methods*, 5: 18-28.
27. Ovsyanik, O.A., Belinskaya, D.B., Kochetkov, I.G., Deberdeeva, N.A. (2016). 'Specific Features of Value Orientations and Social Mindsets of Deviant Teenagers'. *International journal of environmental & science education*, 11(18): 12327-12336.
28. Salakhova, V.B., Bulgakov, A.V., Sokolovskaya, I.E., Khammatova, R.S. and Mikhaylovsky, M.N. (2016). Substantive (Content-Related) Characteristics of Deviant Behavior as a Social and Psychological Phenomenon. *International Journal Of Environmental & Science Education*, 11(17), 10609-10622.



29. Salakhova, V.B., Kalinina, N.V., Belinskaya, D.B., Aygumova, Z.I. and Tkhuo, M.M. (2017). Education as a factor of raising the adaptation potential in a delinquent personality. *Man In India*, 97(3), 1-13.
30. Salakhova, V.B., Lodzhanidze, A.A., Vasyakin, B.S., Sidyacheva, N.V., Ludvig, S.D. (2016). Dynamic Meaning Systems of Consciousness of a Criminal Personality. *International Journal of Environmental & Science Education*, 11(16), 9374-9380.
31. Salakhova, V.B., Oschepkov A.A., Lipatova N.V., Popov P.V. & Mkrtumova I.V. (2016). Features of Social Attitudes and Value Orientations of Youths and Adolescents Prone to Auto-Aggressive Behavior. *International Journal Of Environmental & Science Education*, 11(16), 9017-9025.
32. Salakhova, V.B., Ovsyanik, O.A., Shmeleva, N.B., Lvova, E.N. & Shabanova, O.V. (2016). The Problem of Higher Education in the Executive System of Russian Government. *International Journal Of Environmental & Science Education*, 11(4), 9883-9889.
33. Salakhova, V.B., Tashcheva, A.I., Gridneva, S.V., Zhmurin, I.E., Mikhaylovsky, M.N. (2017). Experimental study of social and psychological correction of the teenage peronality's values and motivation sphere who is prone to deviant behavior. *Modern Journal of Language Teaching Methods (MJLTM)*, Vol. 7, Issue 4, 12-20.
34. Vasyakin, B.S., Berezhnaya M.S., Pozharskaya, E.L., N.A. Deberdeeva (2015). Adaptation of graduates and students of regions to education in higher education institutions of Russia by means of social-psychological training. *Review of European Studies*, 7(3): 88-89.
35. Volosovets, T.V. (2011). *Inclusive Practice in Preschool Education: A Handbook for Pre-school Teachers*. Moscow: Mosaic-Synthesis.

## Social Exclusion As Theoretical Construct: Conceptualization Problems

Tatiana I. Barsukova <sup>1</sup>, Lyudmila A. Shvachkina <sup>2</sup>, Valentina I. Rodionova <sup>3</sup>, Lyudmila A. Saenko <sup>4</sup>, Stanislav T. Baranov <sup>5</sup>

<sup>1</sup> Department of Sociology, North-Caucasian Federal University, Stavropol, Russia.

<sup>2</sup> Department of Social and Humanitarian Disciplines, Institute of Service and Entrepreneurship (Branch in Shakhty), Don State Technical University, Shakhty, Russia.

<sup>3</sup> Department of Social and Humanitarian Disciplines, Institute of Service and Entrepreneurship (Branch in Shakhty), Don State Technical University, Shakhty, Russia.

<sup>4</sup> Department of General and Social Pedagogy, Kuban State University, Krasnodar, Russia.

<sup>5</sup> Department of Social philosophy, North-Caucasian Federal University, Stavropol, Russia.

### Abstract

In the present paper, an attempt is made to generalize the methodology for investigating a new social reality, social exclusion in Russian society in the context of analyzing and evaluating contemporary sociological thought. The author of the paper is relied on the fact that social exclusion is a fairly "uncharted" discourse for the Russian sociological community, that in the social diagnostics the priority of studying poverty is firmly established, which is quite understandable in the conditions of social polarization of Russian society. At the same time, social exclusion is recognized as a state of social groups and strata that are not only marginal, standing on the margins of society and not playing a role in social attitudes and social practices, but also dispersed in social groups and strata "pointy" as risk zones, fears and anxieties. Proceeding from the conceptual generalizations of Russian sociologists, it is concluded that social exclusion contains analytical and prognostic potential within the framework of research and processes of social marginalization, and the interpretation and evaluation of voluntary and forced social ghettoization. It is concluded that social exclusion needs to be conceptualized on the basis of scientific discussion with the aim of achieving a convention on the subject field and methodological guidelines contributing to the legitimization of social exclusion in public discourse.

**Keywords:** social exclusion, poverty, social polarization, social marginalization, social ghettoization, social deprivation.

### Introduction

The Danish scientist P. Abrahamson draws attention to the fact that the term "social exclusion" has developed in the process of studying the processes of marginalization and deprivation in modern society, but has acquired a completely new conceptual content in the context of the end of the "welfare state", the complexities of the "opportunities' equalization" policy and postmodern indifference to the value of social justice (Abrahamson, 2001).

In other words, a discourse of social exclusion is made aimed at the adoption by the society of the formula of social exclusion, the legitimation of the social "bottom" (underclass), the permissibility of social space's destruction by social ghettoization. For sociology, this matters a little in a different sense than for politicians who are concerned about the preservation of power through social populism. P. Abrahamson undoubtedly notes an important fact connected with the fact that social exclusion replaces poverty as an operational factor, becomes a parameter of social stratification classification in modern society, or rather, the choice in favor of the neutrality of social exclusion as a quality resulting from voluntary choice or social spontaneity.

For the domestic sociological thought, where the tradition of the poverty category operationalization is preserved, social exclusion is perceived as a doubtful, although attractive, innovation. The fact is that within the framework of the existing sociological discourse, a conventional attitude to the problems of social stratification is manifested, which is characterized by the "poverty-wealth" scheme. Recognizing

the fact that in the Russian society the paradigm of social polarization operates, that the social structure of Russian society has developed in the context of social transformations that had a massive effect of social deprivation and dis-adaptation, researchers emphasize the limitedness in the use of social exclusion in the context prevailing abroad.

The point is that sociology began to be interested in the problems of social exclusion during the "silent revolution", the change in social norms and values of the social modern's society in which the idea of social progressivity had the effect of achieving social harmony or at least eliminating social imbalances, planning policies, oriented to the localization of poverty. As American sociologists pointed out in the 1970s, social protest in society was caused by the deprivation of social exclusion groups based on ethno-racial, cultural, age and territorial criteria (American sociology, 1972, p. 78).

Forming a certain notion of social exclusion as ghettoization, marginalization of the "minority" that stands outside the majority's social mainstream, it was concluded that in a modern society where the desire for social justice ceased to be a social standard and where self-isolation and distance making from society are manifested in the framework of individual choice preference, American sociologists, thereby, stressed, if not "absurdity" of claims to the practical policy of social justice, then avoiding formula of social stability - instability (Haan, 1998). This was expressed in the fact that for sociology, the farewell to such values as democracy, egalitarianism, social equality became obvious.

Within the framework of the moving to social exclusion, it is necessary to understand that the modern policy of political correctness and tolerance proceeds from the cultivation of differences as a tool for explanation and reconciliation with social inequalities. In other words, poverty cannot be an interpretation of deprivation state for groups that do not practice a consumer lifestyle, possessing ethnic, confessional or gender stereotypes that are difficult to interpret in terms of criteria of relative and, especially, absolute poverty (Andersen, Larsen, 1995).

Thus, social exclusion contains a substitute meaning reflecting the status of groups on the periphery of public life influenced not only by social determinants (societal differentiation), but also by schemes of stigmatization, the formation of despair solidarity, the adoption of marginality as a mechanism of social self-identification. In the works of P. Bourdieu, where social ghettoization is viewed as social division objectified in physical space, social exclusion is the fixation of an individual or group of outsider positions concentrated in the social ghetto (Bourdieu, 1993, p. 103). Social exclusion means a shortage of social and symbolic capitals and, at the same time, "stick" the individual to the place, since "distance" from access to scarce public goods is manifested.

In the Russian society, social exclusion is not included in social diagnostics, it has not become an instrument of public discourse, but the relevance of this problem discussion is significant in that the level of social exclusion, social deprivation determines the life strategies of not only the social bottom and the poor, but also affects behavior and mood of "middle-adapted" sections of society (Russia, 2001, p. 97). Paying attention to the fact that social exclusion is a more multi-faceted concept, compared with poverty, it should be noted that the poverty category has a normative meaning, but perhaps social policy, guided by the phenomenon of social exclusion, acquires new contours connected with the understanding of "hereditary" and "acquired" mechanisms of social exclusion, reduced readiness for social integration and manifestation of social solidarity.

### **Methodology of the study**

As noted above, the "pioneers" in the study of social exclusion are foreign sociologists who share the views of a socially-critical school that are close to the neo-Marxist approach or who proclaim the concept of a social postmodern or later modernity (Wallerstein, 2003, p. 97). In other words, it seems that social exclusion is simply a fashionable term taken to demonstrate the predictive power of sociology, its consonance with social changes and resonances.

Meanwhile, with the legitimization of social exclusion, the paradigmatic changes in sociological vision and understanding are associated.

The point is that social exclusion has is complex for recognition, since it is associated with a psychological emphasis or rejection of system analysis paradigm, the acceptance of society as a sociological "fiction". Within the framework of the transition from society as a system, to a society as an activity, there is a gap between the constructed social relations and social actions oriented toward individual choice. Social exclusion, thus, brings "confusion" to the prevailing sociological discourse for two reasons: the requirements of objectivity and the recognition of pluralism of lifestyles and behavior patterns (Problems, 2016, p. 189).

This looks in such a way that the claims of sociology to the universalism of generalizations are limited by a reference to the social and cultural context, to the fact that poverty is relative within the framework of established patterns of perception and evaluation. Social exclusion is externally a more flexible research tool, but, at the same time, it contains the risk of "washing away" of meanings or values, since it does not include unique identification parameters. Substantially, the main criterion of social exclusion is the "distance" from the majority; it is characterized by social and physical location. The social is that the group like an outsider in relation to the prevailing social and consumer strategies adheres to autonomous social behavior algorithms, which differ from the behavioral patterns accepted as social reference points.

Physical is associated with the appropriation of a "destroyed space" characterized by a destructive socio-ecological environment, the loss of minimum standards of health, communication and personal space. This is not just a phenomenon of "slums", since the theory of social exclusion claims to analyze the state not only of "poor" societies, but also included in the "world center." For supporters of social exclusion theory, it is also important to accept it as a constant infringement of the individual's basic rights (Bauman, 2002, p. 13). The concept of social exclusion is also convenient for studying the process of social marginalization (erosion of social self-identification), the destruction of traditional social communities and the transition of the individual to the sphere of risky social strategies.

Thus, there is an excessive semantic load associated with an attempt to define through social exclusion a phenomenon and a process that can have different origins and vectors. It is supposed that in order to avoid expansionism, social exclusion, first of all, determines the level of deprivation in relation to the receipt of new social and cultural benefits, it concerns not only the "social bottom", but also can be applied to people of different income level (Fedotova, 2005, p.150).

Thus, the choice of methodology for the study of social exclusion in Russian society is determined, on the one hand, by the influence of structural and functional analysis working in the paradigm of poverty, orientation on the model of social differentiation (polarization), on the other hand - by the urgency of social diagnosis scope expanding, to consider groups that by status criteria can be qualified as medium-adapted and do not fall under the poverty line and, at the same time, be carriers of social exclusion, ghettoization, to be characterized by the concentrating on the social micro level and apathy and indifference to public discourse.

This is a new social reality in Russian society, where the classical model of social differentiation seems to be limited if we study both the processes of intergroup and intra-group interaction and the formation of parallel social worlds in which social exclusion manifests itself in behavioral models, ethical codes (morality for "our own"), a reduced level of social empathy. It is actual to believe that social exclusion acquires status, if not universality, then is dispersed in the social space of Russian society.

Proceeding from these circumstances, it can be said that the methodology for investigating social exclusion in Russian society assumes a multidimensional model based on the acceptance of objective parameters determined by social positioning and social capital at the personal and group levels, and

subjective parameters associated with social dispositions, schemes perception and evaluation, algorithms of life activity.

In the research methodology, in order to obtain a sufficiently reliable and verifiable result, it is important to observe presentation nature, to define social exclusion as social well-being and behavioral practice. This makes it necessary to evaluate the structural and activity-based approach realized in the works of the Russian sociologist M.K. Gorshkov (2016), as having a sufficient degree of attractiveness in the analysis of social problems, focused from the state of social exclusion (Gorshkov, 2016, p.15).

Undoubtedly, the research positions are often implicitly influenced by the acceptance of social exclusion as a category of sociological "secondary" role, dependence on foreign sociologists, describing other social states, processes and facts, in comparison with what is happening in Russian society. However, if we proceed from the analytical, explanatory, prognostic potential of the structural-activity-based approach, which includes, on the basis of complementarity, the established schemes of social differentiation, institutional practices, values, it is obvious that social exclusion in Russian society is not a constructible phenomenon, becomes a social property (attitude) as a result of the interiorization of structural conditions, is consolidated as a social habit.

Thus, the methodology of the study is based on the possibilities of studying social exclusion in the dynamics of social moods, expectations, assessments of various groups of Russian society in the context of excessive social inequalities, a reduction in upward social mobility, actuality of life scenarios, and a retreat to the social micro-level.

## Results

Social exclusion has three dimensions in Russian society. The first - structural, is associated with social imbalances, socio-property inequalities, the formation of a social bottom in society, which accounts for 5-7% of the socially active population. A clear factor of social exclusion is the growth of the social category of "homeless people", persons not only without a specific place of residence, but also involved in the process of de-socialization, which is irreversible, meaning social "death." On this indicator, reliable generalizations about the level of social exclusion in Russian society cannot be accepted, since alienation and deprivation are dispersed. At the same time, the growth of this social category means not only the inefficiency of social policy, but also the loss of basic social solidarity, social cooperation, mutual assistance, a family-related crisis.

In this sense, this phenomenon can be designated as symptoms of social exclusion, a "disease" of Russian society. At the same time, it should be emphasized that structural exclusion correlates with the institutional one, with the inequality of access to social resources and benefits, because the mechanisms for the distribution of social resources that allow creating equal starting opportunities are not developed (Ideal society, 2016, p. 153). In the institutional dimension, exclusion also leads to a high degree of institutional distrust, in particular, this is manifested in relation to the institutions of social and legal policy, and to the evaluation of institutions serving group interests, that is, dysfunctional ones in relation to the declared functions and closed to low-resource social groups.

The third dimension of social exclusion is defined as symbolic, based on the consolidation of groups without social, power and symbolic capital of social "outcasts" or guardianship positions. In Russian society, more than half of respondents consider poverty a consequence of subjective qualities and treat the poor through attributing the procedure of social defamation (alcoholism, sloth, lack of initiative, dependent moods). Meanwhile, social exclusion has real social consequences, is included as a behavioral pattern and affects the lifestyle of Russians.

In this context, a high degree of social atomization and disunity can be considered obvious. 20% of Russians declare a sense of social loneliness, the loss of basic social ties. This affects not only the

inhabitants of large cities, where neighboring "unfamiliarity" is manifested, but also affects the life of provincial Russia, where the neighborly mutual aid, tacit social control, is gradually and steadily disappearing, where there is an authority of the circle of loved ones but the role of professional collectives and public organizations is ruined.

While the influence of related, ethnic, clan ties has increased, social exclusion is intensifying, assuming forms of open social aggression, tolerance to social and ethnic phobias, and the construction of images of internal and external enemies. Thus, Russian society is trapped in negative social mobilization, sharply reducing the demand for social activity, social participation and social consolidation.

Social deprivation in Russian society, which fixes social exclusion, is characterized by the dominance of social indifference, social apathy, and individualization of life strategies and the expansion of the "window of opportunities". It means that illegal practices, shadow activities become the norm of behavior, are approved by socially and economically active groups. This conclusion is based on the fact that 30% of the Russian economy is in shadow and this is affected not only by the imperfection of the market system, the tax policy, but also by the social and labor orientations of Russians who are used to believe that informal "contractual" relations do more profit than following legal practices. It is also about tax evasion, the receipt of wages in "envelopes", and the voluntary choice of informal contracts related to the violation of the social and labor rights of employees by the employer (Vodenko, Rodionova, Shvachkina, 2017)

Of course, one should take into account the narrowness of the labor market, unemployment risks, which are of constant nature for the representatives of the low-adapted strata of the population who have fallen into the trap of chronic poverty. At the same time, it should be noted that the middle-adapted strata of Russian society are guided by the adoption of informal norms that enhance social exclusion, there is a corporatization of professional activity, violation of individual rights, arbitrariness of employers and owners through procedures for social exclusion, prohibition of contacts outside the professional environment, the observance of commercial secrets, the obligations of group solidarity, loyalty to the leadership.

It can be stated that social exclusion is reproduced as a behavioral scheme (pattern) and, as a result of poverty and deprivation, generates a position of being outside the social mainstream as a means of social self-determination, a rejection of social self-identification through liberation from social responsibility. In this context, the phenomenon of social paternalism, which is inherent in the expectation of guardianship on the part of the state and, at the same time, the resistance and fears of state intervention in the private sphere, the sphere of illegal freedom, is of interest. In other words, social exclusion is a procedure for constructing an "independent" space of a person or group, in which the norms of unwritten law dominate, but at the same time, the role of the state as a guarantor of basic social values and benefits remains.

At the same time, social exclusion in Russian society has a slightly different conceptual dimension, compared with foreign practices, in particular, the use of very similar in terms of income indicators is expressed in the fact that the Russian society with great stretch can use the criteria of average and individual incomes, as in Britain they exceed the all-Russian more than twice (Russian daily, 2009, page 21). In addition, it is necessary to take into account the specifics of the household, the sphere of self-sufficiency of Russians, differently oriented modes of economy and accumulation.

At the same time, Russian researchers take into account the deprivation of social strata, but they emphasize the unacceptability of the relative approach to poverty, since in Russia the social median of poverty is very low. Therefore, social exclusion "does not work" in conditions of working poverty, which is characteristic of Russian society: for Russians it is difficult to admit that they are socially dependent, hopelessly lose compared to the middle-income segments of the population. The formula "to live no

worse than others" is a social anaphora, replacing the study of social exclusion, which is not recognized by individuals who are in an exception situation.

The point is not that the previous discourse of equality is preserved, that "compels" to construct one's own reality better than it really is. Of great importance is the lack of criteria for the "depth" of social exclusion, the non-actualization of social contacts state, the analysis of relatives' circle, models of life. Meanwhile, these indicators contain a solid sociological array associated with the interpretation of social exclusion in Russian society as characterizing trauma-geneous poverty. In the analytical aspect, we are talking about the need to abandon the fight against poverty in a vertical slice, to take into account the public mainstream and outsiders. On the basis of this, it can be stated that a social policy aimed at the reproduction of poverty is such because it does not project the consequences of social ghettoization by the introduction of "adequate" social medians, stimulates social exclusion, since individuals fall under this category as an object of social policy, oriented towards passive adaptation, as for "those who dream of escaping poverty", it is a priority for them to fill the shortage of resources on the basis of vocational training, territorial mobility, social lending.

There is one more important point connected with the fact that in Russia the understanding of social exclusion is not developed as a barrier to social integration. In studies on this subject, it is often concluded that potential carriers of social exclusion experience temporary difficulties, while isolation from society, the falling out from the mainstream has a temporary extent, is associated with the habit of social exile, life with such "poor people". There is a temptation to categorize groups of social exclusion within the framework of social deviance and, to some extent, delinquency (persons living an antisocial lifestyle, prone to vagrancy, drug addiction, alcoholism), that is, those who need a medicament approach.

In this context, social exclusion is limited by the border, deviation from the social norm and does not focus on societal indicators, moves the focus of attention to the activities of guardianship, control and enforcement structures. In other words, social exclusion in Russian society, as an object of sociological research, requires the introduction of criteria for sociological analysis aimed at determining social self-feeling and social activity as oriented toward social isolation. With the problems of social exclusion, the ambivalence of the social identification strategies of Russians is connected, the fact that Russian researchers from the team of M.K. Gorshkov define as "catastrophism" (Russian Society, 2016, p. 29). An analysis of this group convinces the authors that they are social outsiders" (Russian Society, 2016, p. 29).

However, there is a certain lack of agreement that the destructive influence of this group is ignored on the social self-feeling of "mainstream" groups that avoid, project this group into a state of social dumbness, but it manifests itself in social aggressiveness, expansion of social diseases, fears of "being on social bottom". In other words, social exclusion in Russian society is legitimized in sociological discourse, but it is given the character of a largely marginal state that does not have a societal influence. Such "optimism" generates a lack of demand for research on the real causes and scales of social exclusion, which, as it was noted earlier, is dispersed in social space.

Its effect is based on social localization and if expansion is predicted, then in connection with a sharp, catastrophic deterioration in living conditions "(Russian Society, 2015, p. 30). But this is not a long-term trend, wave-like, which narrows the prospects for analyzing social exclusion as a reality of Russian society. Of course, one cannot believe that the epoch of late modernity has come and, at the same time, it is unprofitable to assert that in Russian society the problems of poverty are determined by the consequences of social transition, the transition from equalizing socialism to a society of accumulation and consumption.

## Discussion

Taking into account the description of social exclusion in Russian society, in the context of its research methodology, one can say that the formulated conclusions and generalizations are open for discussion in

the framework of current and new approaches to understanding the problems of social exclusion. It is important that this issue is legitimized in the sociological community, that there is an aspiration to consider social exclusion not as something "fashionable" and not having prospects, in comparison with the schemes of classical poverty, but an analytical category that allows diagnosing the social structure of Russian society as "mixed" including a traditional and globalized segment.

It is obvious that social exclusion reflects the invasion on the traditional poverty structure of the consumption revolution, the comparison of poverty and wealth standards, social uncertainty, spontaneous choice and differentiation of life strategies. Important significance for the analysis of social exclusion is the ambivalence (friability) of social positions (Chuprov, Zubok, 2001, p. 192). Therefore, we can conclude that for the majority of Russians, and this is the benchmark of sociological analysis, social exclusion, although present in different proportions, depending on the specific situation, has acquired a conscious, and often unconscious, meaning of leaving into social outsider-ship. And when we talk about such a fashionable phenomenon as social downshifting, we are talking not only about the desire to change the activities and residence of young hipsters, but also that Russian society is experiencing a period of consolidation of social exclusion, which differentiates depending on social positioning, but has similar parameters in isolation, the falling out from the mainstream. This fact contains the possibility of developing an integrative paradigm of social exclusion, provided that the subject field and the semantics of the investigation are determined.

### Conclusions

A certain "shaky" image of social exclusion has emerged in Russian society, reflecting the "gaps" in the study of this phenomenon in the context of social poverty theory prevalence. The main conclusion that can be drawn from the above is the following: despite the objective differences with foreign models of social exclusion, very little evidence of social gaps is found. In the Russian society, groups of social exclusion, having social localization in the marginal layers of society, the social bottom, experience a high level of social deprivation, especially in terms of territorial and age characteristics. At the same time, in the mainstream, they do not encroach on an open confrontation with society and seek to limit social contact, to close up them in the social ghetto. If there are alternative struggles abroad to manage, control and strengthen social solidarity in relation to social exclusion, in Russian society, a social policy based on the reproduction of poverty does not notice how society as a whole needs to reintegrate socially exclusive groups with the social mainstream. This is probably complicated by the fact that the groups represented in the "social center" are also influenced by social exclusion, segmented in everyday practices and acting according to schemes of elementary solidarity at the social micro level do not demonstrate the desire to solve emerging social problems through dialogue, the convention on "game rules" in the Russian society (Social factors, 2010, pp. 254).

### References

- Abrahamson, P. (2001). Combining poverty and social exclusion, in: *Social sciences and modernity*, 2, 158-166. American sociology. Perspectives, problems, methods (1972). Moscow: Progress. 390 p.
- Andersen, J., Larsen, J.E. (1995). The Underclass Débat: A Spreading Disease? *Social Integration and Marginalization*. Frederiksberg: Science. 245 p.
- Bauman, Z. (2002). *An Individualized Society*. Moscow: Logos. 390 p.
- Bourdieu, P. (1993). *Sociology of Politics*. Moscow: Socio-Logos. 268 p.
- Chuprov, V.I., Zubok, Yu.A., Williams, K. (2001). *Youth in the field of risk*. Moscow: Science. 231 p.
- Fedotova, V.G. (2005). *Good society*. Moscow: Progress Tradition. 544 p.
- Gorshkov, M.K. (2016). Russian society as it is. In 2 vol. T.1. Moscow: New Chronograph. 416 p.
- Haan, A. de. (1998). Social Exclusion: An Alternative Concept for the Study of Deprivation? *IDS Bulletin*, 29(1), 34-55.
- Ideal society in the dreams of people in Russia and in China (2016). Moscow: New Chronograph. 421 p.



- Problems of theoretical sociology. Issue. 11 (2016). St. Petersburg: Petropolis. 248 p.
- Russia: a transforming society (2001). Moscow: CANON-press-C. 640 p.
- Russian daily life in a crisis (2009). Moscow: Alfa-M. 272 p.
- Russian society and the challenges of time. Book 1 (2015). Moscow: The whole world. 432 p.
- Russian society and the challenges of time. Book 4 (2016). Moscow: The whole world. 400 p.
- Social factors of the consolidation of Russian society: the sociological dimension (2010). M.: New Chronograph. 348 p.
- Vodenko, K., Rodionova, V., Shvachkina, L. (2017). Perspectives of Development of the Russian National Socio-Economic and Political Model. In E.G. Popkova (ed.). Overcoming Uncertainty of Institutional Environment as a Tool of Global Crisis Management (pp. 423-428). Volgograd: Springer International Publishing AG.
- Wallerstein, I. (2003). The end of the familiar world. Sociology of the XXI century Moscow: Logos. 368 p.

## Family Psychological Violence Influence On Adolescent Aggressive Behavior Formation

Valentina I. Rodionova<sup>1\*</sup>, Lyudmila A. Shvachkina<sup>2</sup>, Leila E. Kuznetsova<sup>3</sup>

<sup>1</sup> Institute of Service and Entrepreneurship (Branch in Shakhty), Don State Technical University, Shakhty, Russia.

<sup>2</sup> Institute of Service and Entrepreneurship (Branch in Shakhty), Don State Technical University, Shakhty, Russia.

<sup>3</sup> Institute of Service and Entrepreneurship (Branch in Shakhty), Don State Technical University, Shakhty, Russia.

### Abstract

The main problem, on the solution of which the efforts of the paper authors is directed at, is to study the peculiarities of psychological violence on adolescent personality formation in families that have undergone a marital divorce and who challenge the rights on their child through judicial procedure. Particular attention is paid to the peculiarities study of aggressive behavior manifestation among adolescents who have suffered family violence. The psychological violence influence in the family on the formation of adolescents' aggressive behavior is considered by the authors of the paper from the point of view of the personal-situational approach. An objective indicator of family violence manifestation is the situation of marital divorce and the contestation of parents rights on the child in a judicial procedure. Psychological criteria for the manifestation of family violence are the pathological styles of parenting and the disrupted system of relations between parents and children in the family. The paper presents the results of a scientific study aimed at studying the impact of psychological violence in families on the psycho-emotional state of adolescent children and the specific features of their aggressive behavior. The results of the empirical research, the developed program of family psychological accompany can be used by psychologists in work with families that survived a divorce and who challenge their rights on a child in a judicial procedure.

**Keywords:** family violence, psychological violence in the family, adolescents, marital divorce, aggressive behavior, psycho-emotional state.

### Introduction

The modern world has entered a period of rapid changes, which in the first place, influenced the psychological condition of the younger generation, the forms of its sufferings from neurotic diseases. Adolescents' aggressive behavior is an urgent problem of modern society. The growth of aggression is due to a complex system of factors, such as the worsening of the socio-economic conditions of life, the crisis of the family as an upbringing mechanism, the lack of attention from the side of the school to the psycho-emotional child state, the growth of child somatic diseases and borderline disorders. Freedom, promoted in modern society, led to the lack of the youth behavior control. Adults lose their authority in the eyes of children when they demonstrate aggressive behavior patterns. Violence, competition, the struggle for social statuses and material well-being, selfishness, careerism, manipulation of the loved one's personality are visually demonstrated to children in modern society.

A limited number of scientific studies are devoted to the problem of psychological violence in the family and its impact on the formation of adolescents' aggressive behavior, since the topic of domestic violence is sufficiently closed for public study. In foreign psychology, the works of K. Bron (2014), D.A. Levinson (2014), E. Miller (2015), J. Cabrin (2014), D. Finkelhor (2015) and other scientists are devoted to the problem of domestic violence. In domestic science, family violence was studied by A.A. Andreeva (2000), I.N. Grigovich (2011), D. Eliseev (2011), S.V. Ilyina (1997), A.V. Orlov (1996), T.Ya. Safronova (2015), E.T. Sokolova (2014), E.I. Tsymbal (2015).

In our study, we analyze the problem of psychological violence influence in the family on the adolescents' aggressive behavior formation from the point of view of the personality-situational approach. In our opinion, aggressive behavior is a joint function of the individuals and their environment. In other words, the aggressive behavior of individuals in a society is determined by the impact of the situation in which they find themselves, as well as by the qualities, emotions and inclinations that they manifest in this situation. And domestic violence becomes an extreme negative model of behavior that can form an aggression in a child. Violence in the family is a conscious or unconscious form of destructive social interaction, reflecting the general unhappiness in the family as a whole and violations in the value-normative sphere of the individuals forming it, expressed in the systematic infliction of direct harm to any member of the family, in causing indirect damage to all its members (Kuznetsova, 2012; Rodionova et al., 2018). Domestic violence is most often comprehensive in nature. This can be psychological, physical, economic, intellectual, sexual abuse, neglect of each other. The most common is psychological violence in the family - this is an emotional, psychological insult to a defenseless family member. As psychological violence, psychologists refer to various types of distorted parental attitudes toward the child: manipulative parenthood; hyper-socializing upbringing; disabling ("small and bad") option of parental relationship; absence of the parent or separation of the child from the parent; anxious attachment to the child, associated with exerting pressure on the child, etc. (Kuznetsova, 2015). Adolescence is the most vulnerable to domestic violence and becomes a provocative factor in itself, because ill-treatment or sexual trauma during this period is likely to have far more destructive effects than in the period of relative emotional-personal stability.

The main problem, which is addressed by the efforts of the authors of the paper, is to investigate the processes associated with the facts of family violence that are becoming more frequent in modern society. In connection with this, it is necessary to discuss a whole range of issues, such as modern psychology of adolescents, factors that influence the formation of their aggressive behavior. After all, there is no doubt the pathogenic influence of family violence's various types on the personality and psyche of a child. Violence experienced in childhood can lead to mental disorders, traumatic experiences, victim behavior (Rodionova et al., 2016), the formation of aggressive behavior, as well as to long-term consequences that often affect the rest of life (Safronova, 2014; Safronova, 2015).

### Methods and Materials

The purpose of the study is to study the characteristics of psychological violence manifestation in families whose parents are divorced and contest their rights on the child in court, and its influence on the formation of adolescents' aggressive behavior.

Theoretical and methodological basis for the study are: a personality-situational approach to the consideration of the personality's aggressive behavior. The principle of systemic and determinism nature in the consideration of the family and the consequences of violence application in the family. A significant contribution according to methodological significance is played by the theory of personality development of L.S. Vygotsky (1991), which considers the crises of personality's development as periods of increased sensitivity to domestic violence.

The study was conducted from October 2016 till May 2017 on the basis of the Psychological Center "Phoenix" in Shakhty, Rostov Region. The study involved families whose parents are divorced and contesting their rights on a teenage child in court (10 families) and families whose parents live and parent a teenage child together (10 families). The parents challenging the rights on their child in court were sent by the court to conduct a psycho-diagnostic examination with the purpose of studying the parents' identity, revealing the pathological styles of parenting, studying the relationship between the spouses as parents, the child's attitude to the mother and father, the child's personal characteristics and his psycho-

emotional state. Challenging of the rights on their child most often occurred within the first year after the marital divorce, and also had a protracted character – in 2-3 years after the marital divorce due to the wife's marriage. Families whose parents live together and foster a teenage child together took part in the parent club and gladly agreed to undergo a psycho-diagnostic examination. Thus, 20 couples and 20 children of adolescence (12-14 years) passed the survey, including 8 teenage girls and 12 adolescent boys. In accordance with the goal of empirical psychological research, its program was developed and appropriate methods were chosen. Psycho-diagnostic examination was conducted in four stages. The primary examination was conducted with the purpose of studying the peculiarities of psychological violence manifestation in families who had undergone a marital divorce. The questionnaire of E.G. Eidemiller & V. Yustitskis (2008), "Analysis of family relationships" and a test questionnaire of the parental attitude of V.V. Stolin & V.V. Petukhov (1989) for spouses, the technique of "Adolescents about Parents" of L.I. Wasserman, I.A. Gorkovaya, & E.E. Romitsyna (2001) (for teenagers) were used. At the second stage of the study, the psycho-emotional state, intensity and features of aggressive behavior manifestation in adolescent children were studied. The following tools were used: technique of color choices (adapted version of the color test by M. Lüscher (1971), the test "Self-assessment of mental states" by H. Eysenck & L. Kamin (2002), "Personal aggressiveness and propensity to conflicts" by I.B. Dermanova (2002). To calculate the reliability of the results obtained, statistical data processing methods were used: criterion Q - Rosenbaum test for independent samples, the Bravais-Pearson correlation coefficient  $r$ . In the third stage, after a psycho-diagnostic examination, a psychological accompany program was developed for families who had suffered a marital divorce, practical recommendations for parents aimed at changing the parental position, the adoption of the spouse as the parent of the child, the formation of a psychological readiness for the joint upbringing of the child. The primary examination was conducted to study the features of psychological violence manifestation in families after a marital divorce. At the final stage, the results were summarized; the conclusions were formulated and compared with the conclusions made by other authors as a result of research on the problem under study.

The scientific novelty of the research was manifested in the fact that the phenomenon of psychological violence in the family was examined on the example of divorced families who challenged the rights on their child in a judicial procedure. The influences of psychological violence in families on the psycho-emotional state of adolescent children and the features of their aggressive behavior have been studied (Orlov, 1996, Miller, 2015). Its theoretical significance lies in the fact that the concepts of domestic violence are analyzed and generalized; the influence of psychological violence in families on the formation of aggressive behavior of adolescents is shown. The developed program of psychological accompany of families can be used by psychologists in working with families who survived a divorce and who challenge their rights on a child in a judicial procedure.

## Results

The study involved families whose parents were divorced and contesting their rights on a teenage child in court (10 families) and families whose parents lived together and fostered a teenage child together (10 families).

The conversation with parents and children showed that in families whose parents were divorced and contesting their rights on the child, various types of family violence were constantly being used: physical violence by the mother and father (physical punishment, beatings), physical abuse of the father in relation to the mother before the marital divorce, economic violence (fathers often did not pay child support, mothers forbidden children to take gifts from the father, etc.), disregarded for the opinion of the child and there was a negative scornful attitude of the spouses to each other, psychological insults of the family unprotected member. Intellectual violence in the family is manifested in the imposition of one's opinions, attitudes and feelings on the child, a priori expectation of the desired reaction from him or her. The

separation of the child from the father and the ban on communication with him is a psychological abuse by the mother in relation to both the child and the father of the child who wants to communicate with his child. Often, the conflict includes grandparents who want to communicate with their grandchildren. In families whose parents live together and foster a child of adolescence together, parents try to take into account the interests of each other and the child. They clearly plan the family budget and allocate funds in accordance with the needs of the child, do not use physical violence, try to be reserved in communication and to understand the conflict situation without screaming and punishing. They listen to the opinion of the child, give him or her right to decide and choose (Tsymbal, 1995, 2015).

So, in families whose parents are divorced and contest their rights on the child, the pathological style of upbringing prevails among the mothers: the dominant hyper protection. The child is in the center of attention of the mother, who gives him a lot of energy and time, but at the same time, deprives him of independence, putting a number of restrictions and prohibitions. The mother manipulates the child, forbids him to communicate with the father, inspires the child that the father is bad and the father does not need a child. In some families, mothers apply economic and physical violence, trying to make the child to abandon from the father. Single and independent visits of the child to the father are accompanied by a negative reaction, screams and punishments. Unconsciously, without accepting the masculine qualities, qualities of the father (especially if the child resembles a father), the mother imposes the undesirable qualities of the father to the child, reminding him that the father is bad, and he looks like a bad father (Andreeva, 2015; Bron, 2014; Grigovich, 2011). Mothers are trying to bring up the child's feminine qualities, which is dangerous for boys, who become dependent and dependent. The instability of education, characteristic of mothers is dangerous. They use a sharp transition from very strict to liberal, and then, on the contrary, the transition from significant attention to the child to emotional rejection. There is an expansion of parental feelings sphere in connection with the growing conflict between spouses - for mothers the child becomes something big, the meaning of life. It is necessary to consider how the style of parenting has affected adolescents.

**Table 1.** The style of upbringing in families whose parents are divorced and contesting their rights on the child in court (b.)

Indicators.	Mother.	Father.
Hyperprotection.	10	9
Hypoprotection.	3	2
Indulging.	5	10
Ignoring the needs of the child.	4	1
Excessive requirements-duties.	3	3
Insufficiency of the child's obligations.	2	2
Excessive requirements-prohibitions.	5	3
Insufficiency of requirements-prohibitions.	1	2
Excessive sanctions.	5	2
Minimality of sanctions.	2	1

The instability of education style.	5	4
Expansion of parental feelings sphere (PFE).	8	9
Educational uncertainty (EU)	4	5
Phobia of a child's loss (FL).	5	9
Underdevelopment of parental feelings (UdF).	3	4
Projection on the child one's own undesirable qualities (PUQ).	5	2
The bringing of conflict between spouses into the sphere of education (BC).	5	5
Preference for masculine qualities (PMQ).	1	3
Preference for female qualities (PFQ).	5	1

In families whose parents are divorced and contesting their rights on the child, the pathological style of upbringing prevails among the fathers: indulgent hyper protection. The child becomes the most important person for fathers; they are ready to satisfy any of his or her desires. Especially this feeling is exacerbated in the situation of the prohibition to see and meet with the child. The parental insecurity, the expansion of parental feelings sphere, phobia of a child loss, the conflict between spouses in the sphere of fostering are expressed.

Thus, parents develop a contradictory type of upbringing - a combination of dominant hyper protection with indulgent hyper protection.

In families whose parents live together, pathological styles of upbringing have not been identified. Mothers try to give the child a lot of time, effort, but at the same time they present a sufficient number of requirements-duties, prohibitions and sanctions. Fathers are optimally concerned with meeting the needs of children, applying a sufficient number of requirements, sanctions. The fostering position of parents is characterized by confidence, stability and consistency. One can consider the results of the study in Table 2.

**Table 2.** The style of fostering in full families (b.)

Indicators.	Mother.	Father
Hyperprotection.	5	3
Hypoprotection.	2	2
Indulging.	3	4
Ignoring the needs of the child.	1	2
Excessive requirements-duties.	2	2

Insufficiency of the child's obligations.	1	0
Excessive requirements-prohibitions.	1	2
Insufficiency of requirements-prohibitions.	2	1
Excessive sanctions.	3	2
Minimality of sanctions.	1	1
The instability of education style.	2	1
Expansion of parental feelings sphere (PFE).	3	2
Educational uncertainty (EU)	3	2
Phobia of a child's loss (FL).	2	1
Underdevelopment of parental feelings (UdF).	1	2
Projection on the child one's own undesirable qualities (PUQ).	1	0
The bringing of conflict between spouses into the sphere of education (BC).	1	2
Preference for masculine qualities (PMQ).	1	2
Preference for female qualities (PFQ).	2	0

The test-questionnaire of the parental attitude (author's development of Russian psychologists V.V. Stolin & V.V. Petukhov (1989) revealed the peculiarities of parents' attitude toward children. The results of the study are presented in Tables 3 and 4.

**Table 3.** Type of parental attitude in families whose parents are divorced and contesting their rights on the child in court (b.)

Indicators	Mother	Father
Acceptance-rejection.	17 b. (56,6%)	8 b. (26,6%)
Cooperation.	4 b. (50%)	3 b. (37,5%)
Symbiosis.	4 b. (57%)	7 b. (100%)
Authoritarian hypersocialization.	6 b. (86%)	2 b. (28,5%)
Infantilization ("little loser").	5 b. (62,5%)	3 b. (37,5%)

So, in families whose parents are divorced and contesting their rights on the child, among mothers dominates the authoritarian hyper socialization and as for the parental attitude to the child of the fathers – it is symbiosis. Mothers behave authoritatively, demand unconditional submission, and impose their demands on the child. They do not see the personality in the child; they do not try to understand what

the child wants and why he or she does it. They try to impose their will on the child; do not want to accept to his or her point of view. For the manifestation of self-will the children are severely punished. Trying to become emotionally close to the child, the mother does not accept a number of the child's qualities, may feel anger, annoyance, irritation, resentment towards the child (Ilyna, 1997; Cabrin, 2014). Mothers do not trust their children, are annoyed at their failure and ineptitude, consider them small and try to protect their children from the difficulties of life and strictly control actions. Fathers show complete acceptance in relation to the child, an increased need for contact and emotional intimacy. Fathers respect the individuality of the child, sympathize with him, and seek to spend a lot of time with the child, approve of his or her interests and plans. Fathers feel themselves with the child as a unity; strive to satisfy all the needs of the child, to protect him or her from the difficulties and troubles of life.

**Table 4.** Type of parental relationship in full families (b.)

Indicators	Mother.	Father.
Acceptance-rejection.	6 b. (20%)	5 b. (16,6%)
Cooperation.	7 b. (87,5%)	8 b. (100%)
Symbiosis.	5 b. (71%)	3 b. (37,5%)
Authoritarian hypersocialization.	2 b. (28,5%)	3 b. (42,8%)
Infantilization ("little loser").	1 b. (12,5%)	0 b. (0%)

In families whose parents live together, mothers have a parental attitude to the child - symbiosis and cooperation, and fathers have cooperation one (social desirability). Parents are interested in the affairs and plans of the child, try to help the child in everything, sympathize with him. They highly appreciate the child's intellectual and creative abilities, feel proud for him, encourage initiative and independence, and try to be on equal terms with the child. Parents trust the child; trying to support his point of view in controversial issues. Mothers feel great emotional attachment to the child, heightened anxiety and responsibility.

With the help of the L.I. Wasserman's technique (Wasserman, Gorkovaya & Romitsyna, 2001) "Teens about parents" the peculiarities of family relationships through the eyes of adolescents were studied. The results of the study are presented in Table 5. The results of the study showed that adolescents whose parents were divorced and contesting the rights on their child identified significant violations of the relationship in the family. Adolescents emphasize the predominance of directive and hostility in the parenting from the side of the mother; inconsistency and autonomy in the parenting from the side of the father. Children, not having an emotional contact with their father, believe that they do not need him. The most negative is the inconsistency and unpredictability of the father's behavior. Many children have a negative experience of physical and psychological violence in the family before the divorce. At the time of the study, they have a serious psychological and even physical impact on the part of the mother, which forbids them to communicate with their father. Adolescents, whose parents live together, are more satisfied with the relationships in the family. Adolescents emphasize the predominance of positive interest and consistency in the upbringing of mother and father. Children do not have a negative experience of domestic violence; they feel emotional attachment to their parents. They strive to build mutual relations on trust and mutual understanding, they need help and support, and they accept the opinion of their parents. When sons assessed their father's style of family upbringing, they noted the



tendency to directedness against a background of high positive interest. Fathers have authority among their sons. Their power over their sons is expressed mainly in the management and timely correction of the child's behavior, excluding ambitious despotism. Psychological acceptance of the son by the father is based, first of all, on trust.

**Table 5.** Features of family relationships through the eyes of adolescents (b.)

Scales.	Adolescents who are brought up by divorced parents who challenge the rights on the child.	Teens brought up by parents living together.
Daughter's assessment of her mother.		
Scale of positive interest.	2	5
Scale of directedness.	5	2
The scale of hostility.	3	1
Scale of autonomy.	2	3
Scale of inconsistency.	4	1
Daughter's assessment of her father.		
Scale of positive interest.	3	4
Scale of directedness.	1	3
The scale of hostility.	0	1
Scale of autonomy.	3	2
Scale of inconsistency.	3	1
Son's assessment of her mother.		
Scale of positive interest.	3	4
Scale of directedness.	4	2
The scale of hostility.	3	0
Scale of autonomy.	4	3
Scale of inconsistency.	4	2
Son's assessment of her father.		
Scale of positive interest.	2	3
Scale of directedness.	1	2

The scale of hostility.	1	1
Scale of autonomy.	3	1
Scale of inconsistency.	5	0

So, psychological violence in families whose parents are divorced and challenging the rights on their child in a judicial order is manifested in the formation of pathological styles of parenting and deformation of the parental attitude. A contradictory type of upbringing has been revealed - the combination of dominant hyper protection with indulgent hyper protection. Mothers have more parental attitude to the child - authoritarian hyper socialization, the fathers - symbiosis. Adolescents emphasize the predominance of directedness and hostility in the fostering of the mother; inconsistency and autonomy in the parenting of the father.

It is necessary to study the features of aggressive behavior, the psycho emotional state of adolescents who are brought up by divorced parents challenging the rights on their child in a judicial order.

First of all, the influence of psychological violence in the family on the psycho emotional state of adolescents has been studied. G. Eysenck's test (Eysenck & Kamin, 2002) on the self-assessment of the mental state and the technique of color choices (adapted version of M. Lüscher's (1971) color test was used.

The results of the study presented in Table 6 show that adolescents who have experienced psychological abuse in the family and adolescents raised in full families show significant differences in such indicators of mental state as anxiety (Q = 20, p <0.01), aggressiveness (Q = 26; p <0.01) and frustration (Q = 26; p <0.01).

**Table 6.** Psycho-emotional state of adolescents who have suffered psychological abuse in the family (b.)

Indicators.	Teenagers who have suffered psychological abuse in the family.	Teenagers who have not suffered psychological abuse in the family.	Q Rosenbaum criterion Q Critical. = 9.
The "anxiety" scale.	16	11	Q=20; p<0.01
Scale of "frustration."	18	9	Q=26; p<0.01
Scale of "aggressiveness".	20	11	Q=26; p<0.01
The "rigidity" scale.	13	14	Q=3; p<0.01

Teenagers who have suffered psychological abuse in the family have a reduced mental state: anxiety, aggressiveness, frustration is expressed. Heteronomy is expressed (passivity, sensitivity, self-doubt, propensity to dependent position from others), concentricity (focus on their own problems); the contradictory nature of the individual, the tone of the parasympathetic nervous system predominates, and the capacity for work is reduced. The presence of stress is expressed. The results of the study are clearly shown in Table 7.

**Table 7.** Psycho Emotional state of adolescents who have undergone psychological violence in the family (Lüscher's color test) (6.)

Indicators.	Teenagers who have suffered psychological abuse in the family.	Teenagers who have not suffered psychological abuse in the family.
Heteronomy - autonomy.	1,9	-2,6
Concentricity - eccentricity.	4,9	-4,2
Balance of personality properties.	0,7	-0,4
Balance of the vegetative system.	-9,2	8,3
Working capacity.	9,1	20,9
Presence of a stressful condition.	29,8	2,1

Adolescents, who have not experienced psychological abuse in the family, possess the mental state which is within the norm. The average level of anxiety, aggressiveness, and frustration tension is typical. Autonomy is revealed (independence, activity, initiative, independence, propensity to domination, aspiration to self-affirmation, to success); eccentricity (adolescents are interested in the environment as an object of influence or as a source of assistance); stability of personality. The predominance of the sympathetic nervous system tone is characteristic, work capacity is high, and the stress state is not expressed.

It is necessary to study the adolescents' propensity to aggressive behavior who have suffered psychological violence in the family with the help of the questionnaire "Personal aggressiveness and propensity to conflicts" of I.B. Dermanova (2002). The results of the study presented in Table 8, show significant differences in the level of positive (Q = 15, p <0.01) and negative aggressiveness (Q = 21; p <0.01), propensity to conflicts (Q = 42; p <0.01) among the adolescents who have undergone a family violence and adolescents raised in favorable family conditions.

**Table 8.** Peculiarities of adolescents' aggressive behavior who have suffered psychological abuse in the family (b.)

Indicators.	Teenagers who have suffered psychological abuse in the family.	Teenagers who have not suffered psychological abuse in the family.	Q Rosenbaum criterion Q Critical. = 9.
Positive aggressiveness.	9	14	Q=15; p<0.01
Persistence.	4	8	Q=12; p<0.01
Intractability.	5	6	Q=3; p<0.01
Negative aggressiveness.	15	8	Q=21; p<0.01
Intolerance.	8	5	Q=9; p<0.01
Vindictiveness.	7	3	Q=12; p<0.01

propensity to conflicts	33	18	Q=42; p<0.01
Uncompromisingness.	8	4	Q=12; p<0.01
Irascibility.	9	5	Q=12; p<0.01
Sensibility.	8	5	Q=9; p<0.01
Suspiciousness.	8	4	Q=12; p<0.01

For teenagers who have experienced psychological abuse in the family are typical: a high level of negative aggressiveness, manifested in increased intolerance and vindictiveness towards others and a moderate level of positive aggressiveness. Against the background of intransigence, there is not enough perseverance in achieving the goals set. Adolescents' propensity to conflicts is high, they strive for rivalry in the conflict, and they show emotional lability, irritability, and impulsiveness.

Adolescents, who have not experienced psychological abuse in the family, possess an increased level of positive aggressiveness, consisting of a sufficiently high assertiveness and a moderate level of negative aggression. Intolerance to the opinions of others is moderate, vindictiveness is not characteristic. Adolescents are not conflict, prefer peaceful solutions to problems, and seek cooperation, mutual concessions in the conflict (Levinson, 2014; Miller, 2015). Emotional stability is moderate; they are moderately offensive, moderately suspicious. As we see, there is a correlation between the indicators of psychological violence in the family and the indicators of adolescents' aggressive behavior with the help of the r- Bravais -Pearson correlation analysis. The results are shown in Table 9.

**Table 9.** Correlation coefficients of psychological violence indicators in the family and negative aggressiveness (r-Bravais-Pearson criterion, p <0.01)

Indicators of psychological violence in the family.	Empirical correlation coefficient.	Conclusion on the importance of communication.
Excessive requirements-prohibitions.	0,501	significant
Excessive sanctions.	0,679	significant
Authoritarian hypersocialization.	0,824	significant
Directedness.	0,735	significant
Hostility.	0,628	significant

A significant correlation was found between the level of negative aggressiveness and the indicators of psychological violence in the family: the excess of the requirements-prohibitions -  $r = 0.501$ ,  $p < 0.01$ ; excessive sanctions -  $r = 0.679$ ,  $p < 0.01$ ; authoritarian hyper-socialization -  $r = 0.824$ ,  $p < 0.01$ ; directedness -  $r = 0.735$ ,  $p < 0.01$ ; hostility -  $r = 0.628$ ,  $p < 0.01$ .

So, psychological violence in families whose parents are divorced and challenging the rights on their child in court, leads to a significant deterioration in the psycho-emotional state and the adolescent children's aggressive behavior formation. The adolescents' features of aggressive behavior are characterized by a high level of negative aggressiveness, manifested in increased intolerance and vindictiveness towards others. Against the background of intransigence, there is not enough perseverance in achieving the goals set. High affective aggression leads to the adolescents' increased propensity to conflicts.

### Conclusion

The problem of family violence in the modern world has firmly taken its place among other topical problems of psychological science. Undoubtedly, it is far from being resolved and requires new research programs, original methodological approaches and close attention to the specifics of psychotherapeutic work with children who survived various types of family violence.

The statistical data on prevalence and the degree of domestic violence in our country are extremely contradictory and underreported. Statistics of Russian emergency psychological services for children and adolescents (Trust Phone) indicate that the most common form of family violence is psychological violence.

Psychological violence can be included into chronic patterns of behavior, such as humiliation, insult, bullying and ridicule on the child, deliberate manipulation of the adult body of the child as an object, ignoring its subjective characteristics (freedom, dignity, rights), destroying of the attachment relationship between adults and the child, or, on the contrary, fixing this relationship, as well as actions leading to various deformations and violations of mental (behavioral, intellectual, emotional, volitional, communicational, personal) development. Modern psychological science comes to the conclusion that adolescence is the most vulnerable to domestic violence and becomes a provocative factor in itself, because ill-treatment during this period is more likely to have a much more destructive effect than in the period of relative emotional and personal stability. The most significant conclusion which the child learns is the pattern of rapist-victim relationship with the orientation that one's needs can be met only as a "victim" or "rapist".

Today, the family is understood not only as the basis for the development of the child's personality, but also as the basis for the development of the whole society. People have ceased to trust each other, have forgotten how to cooperate in solving common problems. Violence in the family, when parents are rude and disrespectful to one another, insult, beat up their children, leads to the consolidation of aggressive patterns of behavior and deformation of all social development.

The purpose of our study is to study the characteristics of psychological violence manifestation in families whose parents are divorced and contest their rights on the child in court, and its influence on the formation of adolescent children's aggressive behavior.

The study involved families whose parents are divorced and contesting their rights on a teenage child in court (10 families) and families whose parents live together and raise a teenage child together (10 families).

An empirical study has shown that psychological violence in families whose parents are divorced and challenging their rights on the child in court is manifested in the formation of pathological styles of parenting and deformation of the parental attitude. A contradictory type of upbringing has been revealed - the combination of dominant hyper protection with indulgent hyper protection. The child is in the center of attention of the mother, who gives him a lot of strength and time, but at the same time, deprives

him of independence, putting many restrictions and prohibitions. The mother manipulates the child, forbids him to communicate with the father, inspires the child that the father is bad and the father does not need a child. In some families, mothers apply economic and physical violence, seeking the child's renunciation of the father. Single visits to the father are accompanied by a negative reaction, screams and punishments. Unconsciously, without accepting masculine qualities (especially if the child is like a father), the mother imposes the undesirable qualities of the father to the child, reminding him that the father is bad, and he looks like a bad father. Mother shows instability of parenting; try to foster the child's feminine qualities, which is a danger for boys who become dependent and dependent. Characteristic is the expansion of parental feelings sphere in connection with the escalating conflict between spouses: for both mothers and fathers the child becomes something big, the meaning of life. In the situation of the prohibition to see and meet with the child, the fathers are ready to satisfy any of his desires. The fathers' parental insecurity and a phobia of a child's loss are expressed.

Mothers' parental attitude to the child is - authoritarian hyper socialization, the fathers' - symbiosis. Mothers' behavior is authoritarian, they demand unconditional submission, and impose their demands on the child. They do not see the personality in the child; they do not try to understand what the child wants and why he does it. They try to impose their will on the child, unable to accept his point of view. For the manifestation of self-will - the child is severely punished. Having tried to become emotionally close to the child, the mother does not accept a number of his qualities, may feel anger, annoyance, irritation, resentment towards the child. Fathers show complete acceptance in relation to the child, an increased need for contact and emotional intimacy. Fathers respect the individuality of the child, sympathize with him, and seek to spend a lot of time with the child, approve of his interests and plans. Fathers feel themselves with the child as a unity; strive to satisfy all the needs of the child, to protect him from the difficulties and troubles of life.

Adolescents whose parents are divorced and contesting their rights on the child have identified significant disruptions in the relationship in the family. Adolescents emphasize the predominance of directedness and hostility in the fostering of the mother; inconsistency and autonomy in the fostering of the father. Children, not having an emotional contact with their father, believe that they do not need him. The most negative is the inconsistency and unpredictability of the father's behavior. Many children have a negative experience of experiencing physical and psychological violence in the family before the divorce. At the time of the study, they have a serious psychological and even physical impact on the part of the mother, which forbids them to communicate with their father.

Psychological violence in families whose parents are divorced and challenging their rights on the child in court, leads to a significant deterioration in the psych emotional state and the formation of adolescents' aggressive behavior. Psychological violence is often associated with adolescents' victim behavior (Rodionova et al., 2018).

Teenagers who have suffered psychological abuse in the family have a reduced mental state: anxiety, aggressiveness, frustration are expressed. Heteronomy is expressed (passivity, sensitivity, self-doubt, propensity to dependent position from others), concentricity (focus on their own problems); the contradictory nature of the individual, the tone of the parasympathetic nervous system predominates, and the capacity for work is reduced. The presence of stress is expressed.

Teenagers who have experienced psychological abuse in the family, possessed a high level of negative aggressiveness, manifested in increased intolerance and vindictiveness towards others and a moderate level of positive aggressiveness. Against the background of intransigence, there is not enough perseverance in achieving the goals set. Adolescents' propensity to conflicts is high, they strive for rivalry in the conflict, and they show emotional lability, irritability, impulsiveness, offensiveness, suspicion. A

significant correlation was found between the level of negative aggressiveness and the indicators of psychological violence in the family: the excess of the requirements-prohibitions -  $r = 0.501$ ,  $p < 0.01$ ; excessive sanctions -  $r = 0.679$ ,  $p < 0.01$ ; authoritarian hyper-socialization -  $r = 0.824$ ,  $p < 0.01$ ; directedness -  $r = 0.735$ ,  $p < 0.01$ ; hostility -  $r = 0.628$ ,  $p < 0.01$ .

Thus, psychological violence in families whose parents are divorced and challenging their rights on the child in court, leads to a significant deterioration in the psycho-emotional state and the formation of adolescent children's aggressive behavior. Features of adolescents' aggressive behavior are characterized by a high level of negative aggressiveness, manifested in increased intolerance and vindictiveness towards others. Against the background of intransigence, there is not enough perseverance in achieving the goals set. High affective aggression leads to adolescents' increased propensity to conflicts.

So, children who are brought up in families after a marital divorce become victims of psychological violence by their parents and need psychological help aimed at normalizing their psych emotional state and reducing the level of negative aggression, propensity to conflicts and impulsiveness.

The developed program of psychological accompany for families who have experienced the marital divorce included: 3 psychological consultations with parents, 12 individual sessions with adolescent children for 60 min.

Psychological work with families was carried out in two directions:

1. Psychological work with parents, including psychological counseling of parents to change the parental position, to form coherence and consistency of parenting styles, harmonize relationships between former spouses; adopt the role of the parent.
2. Psychological work with adolescents who have undergone family violence, which consisted in carrying out individual psycho-correctional work aimed at normalizing the psycho-emotional state of adolescents, suppressing negative feelings related to the separation of parents, the formation of harmonious positive attitudes of adolescents to parents, the adoption of new family members, reducing the adolescents' negative aggression, training constructive conflict resolution strategies.

In the process of psychological counseling, parents were given practical recommendations aimed at harmonizing family relationships, many parents were asked to undergo family psycho-correction. Children, who experienced violence in the family, and prone to aggressive behavior, took part in individual corrective sessions with a psychologist. Such methods of work as conversation, role play, NLP, art therapy, fairy-tale therapy, methods of self-regulation: breathing exercises, meditation-visualization, etc. were used. The work carried out helped to improve relations in the family, between parents and children, improved the psycho-emotional state of adolescents, reduced negative aggression, impulsiveness, irritability, and increased resistance to conflict .

## References

- Andreeva, A.A. (2015). Domestic Violence as a Social Problem of Modern Society. *Actual issues of modern pedagogy: materials of VI Intern. scien. Conf.* Ufa, pp.1- 3.
- Bron, K. (2014). Psychological Violence in the Family. St.Petersburg: Speech.
- Cabrin, J. (2014). Aggressive behavior of adolescents who survived domestic violence. St. Petersburg: Peter.
- Dermanova, I.B. (2002). Diagnostics of emotional and moral development. St. Petersburg: Peter.
- Eidemiller, E.G. & Yustitskis, V. (2008). Psychology and psychotherapy of the family. St. Petersburg: Peter.

- Eliseev, D. (2011). Violence in the family as a problem of modern society. Moscow: Freedom.
- Eysenck, H. & Kamin, L. (2002). Intelligence: The Battle for the Mind: How mental abilities are formed. Moscow: Eksmo-Press.
- Finkelhor, D. (2015). Psychological Violence within the Family and Child Health. Moscow: Globe.
- Grigovich, I.N. (2011). Syndrome of child abuse. General issues and physical abuse: a manual for students and doctors. St. Petersburg: PetrSU.
- Ilyina, S.V. (1997). On the problem of violence influence experienced in childhood on the formation of personality disorders. *International Conference in memory of A.R. Luria*. Moscow: Moscow State University.
- Kuznetsova, L.E. (2012). Peculiarities of psychological violence manifestation in families where parents challenge the rights on the child in a judicial procedure. *Family in the context of pedagogical, psychological and sociological research: materials of the III International Scientific and Practical Conference*. Penza, pp. 125 - 128.
- Kuznetsova, L.E. (2015). Peculiarities of psychological violence manifestation towards children in families after a marital divorce. *The young scientist*, 23, 879-882.
- Levinson, D.A. (2014). Psychological Violence in the Family. St. Petersburg: Peter.
- Lüscher, M. (1971). The Lüscher Color Test / transl. and ed. by Ian A. Scott. New York: Pocket Books. URL: [http://psihologiadla.ucoz.ru/load/cvetovoj\\_test\\_ljushera/1-1-0-7](http://psihologiadla.ucoz.ru/load/cvetovoj_test_ljushera/1-1-0-7)
- Miller, E. (2015). Aggressive behavior of adolescents who are brought up in dysfunctional families. Moscow: Olma-Press.
- Orlov, A.V. (1996). Psychological violence in the family - definition, aspects, the main directions of psychological assistance provision. *Psychologist in the kindergarten*, 3, 86- 89.
- Rodionova, V.I., Shvachkina, L.A., Kuznetsova, L.E., Eroshenko, A.N. (2018). Victim behavior manifestation in modern public culture // *Modern Journal of Language Teaching Methods*, 21(8), 139-149.
- Rodionova, V.I., Vodenko, K.V., Bokachev, I.A., Levchenko, N.A., Shvachkina, L.A. (2016). The Specific Features of a Government Control over Higher Education. Considering the Interests of Parties to the Social and Labor Relations. *The Social Sciences*, 21(11), 5241-5246.
- Safronova, T.Ya. (2015). Psychological Violence in the Family. Moscow: RAMS.
- Sokolova, E.T. (2014). Aggressive teenager. Moscow: Olma-Press.
- Stolin, V.V. & Petukhov, V.V. (1989). The subject and tasks of psychological science and practice, Moscow: Moscow State University.
- Tsymbal, E.I. (1995). Legal protection of children from violence and neglect of their basic needs. *Bulletin of psychosocial and correctional-rehabilitation work*, 2, 67-85.
- Tsymbal, E.I. (2015). Family psychotherapy of disadvantaged families. St. Petersburg: Peter.
- Wasserman, L.I., Gorkovaya, I.A. & Romitsyna, E.E. (2001). Psychological technique "Adolescents about parents" and its practical application. St. Petersburg: Peter.